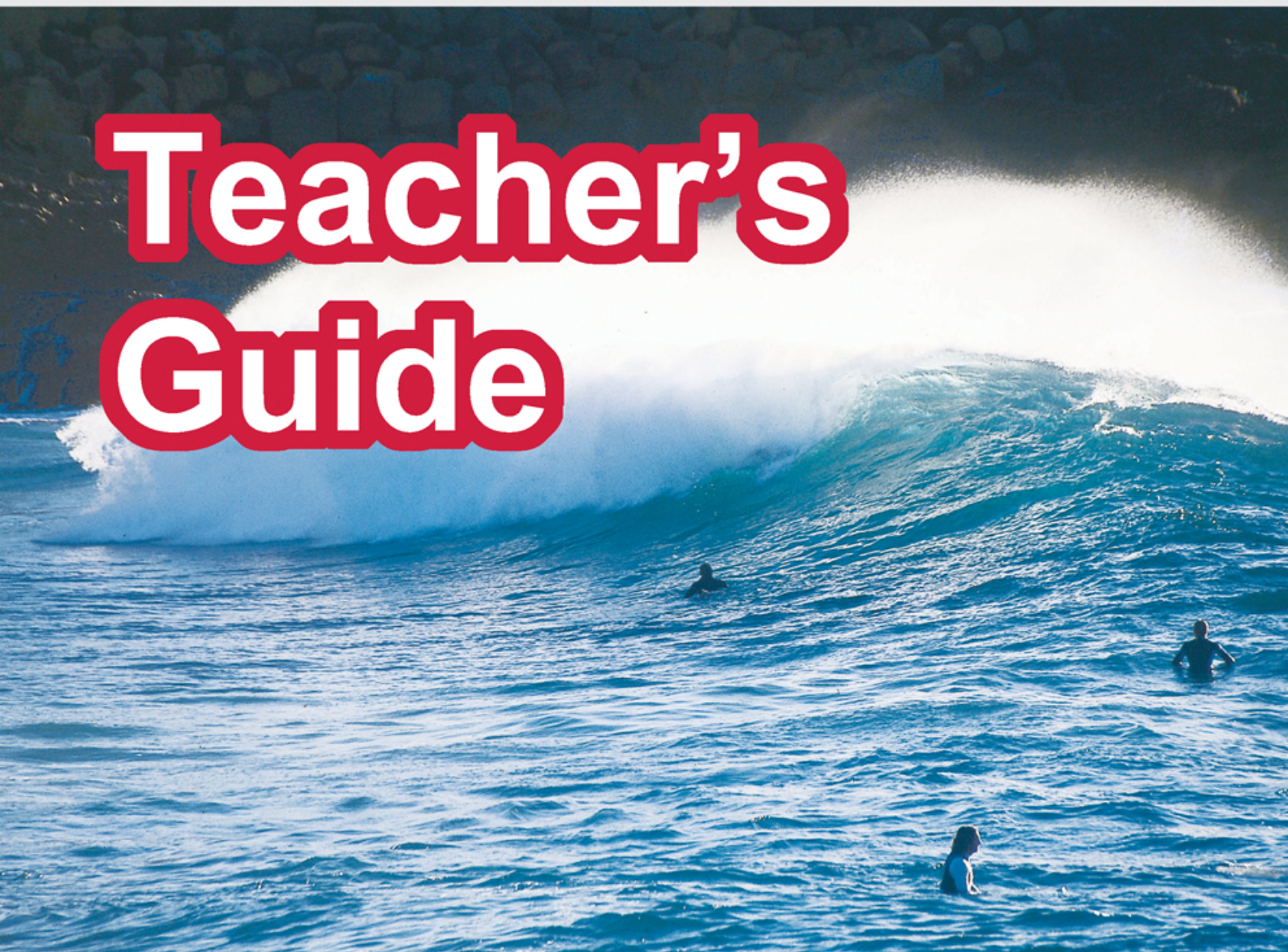


Marine Science  
For Australian Students

# Oceanography Exercises

# Teacher's Guide



Wet Paper

© Copyright R. Moffatt, 2025

Except as permitted by the copyright law applicable to you, you may not reproduce or communicate any of the content on this website, including files downloadable from this web site, without the permission of the copyright owner.

The Australian Copyright Act allows certain uses of content on the internet without the copyright owner's permission. This includes uses by educational institutions for educational purposes, and by Commonwealth and State government departments for government purposes, provided fair payment is made.

For more information, see [www.copyright.com.au](http://www.copyright.com.au) and [www.copyright.org.au](http://www.copyright.org.au).

**Published by**

Wet Paper Publishers and Consultants

PO Box 540

COOLANGATTA 4225

[www.wetpaper.com.au](http://www.wetpaper.com.au)

[info@wetpaper.com.au](mailto:info@wetpaper.com.au)

**ISBN (2025 E Pub)**

978-1-86283-164-3



**Wet Paper**

# Contents

<b>Part A: Oceans</b>	<b>5</b>
A1. What does the topography of the ocean look like?	5
A2. What part of the world oceans does Australia own?	6
A3. What major geological movements have occurred in Australia?	7
A4. What happened in ice age Australia?	8
A5. What is climate change and how does it affect the ocean?	10
A6. How do ocean currents form?	12
A7. How does the El Niño current affect thermoclines in the sea?	14
A8. What effect does El Niño cause?	15
A9. What is so special about the EAC?	16
A10. What is so special about the Leeuwin current?	17
A11. When do Australian ocean sea temperatures change?	18
A12. How is marine life in Australia governed by ocean temperature?	19
A13. What causes Tsunamis?	20
<b>Part B: Coastlines</b>	<b>22</b>
B1. What are some characteristics of waves?	22
B2. How fast do waves travel?	23
B3. How does weather affect waves?	24
B4. What happens when currents approach a shore?	26
B5. How is sand made and transported in a coastal system?	27
B6. Why do tides change over the month?	28
B7. What happens to waves as they approach a beach?	30
B8. How does sand get onto a beach?	32
B9. What are sand dunes and how are they made?	33
B10. Can we classify sand grain sizes found on a beach?	34
B11. Can we determine the percentage composition of sand on a beach?	36
B12. How do you draw a beach profile?	38
B13. How do the dune cycles occur?	40
B14. What happens when the dune cycle is broken?	41
B15. When is beach nourishment a solution to coastal management?	42
B16. Can we make a model to identify coastal ecosystems?	46
B17. Can we use a template to show wave refraction?	48
<b>Part C: Seawater and pollution</b>	<b>50</b>
C1. How much plastic pollution is there in the sea?	50
C2. How much salt is in seawater?	51
C3. Can we make and establish a test for seawater?	52
C4. Can we determine how much oxygen there is in seawater?	56
C5. What effect does marine pollution have on dolphins?	58
C6. Why is DDT a problem in the marine food chain?	60
C7. What are some of our seas contaminated with?	62
C8. What effect does oil have on feathers?	64
C9. What happens in an oil spill?	66
C10. What impact do acid sulfate soils have on the sea?	70
C11. What effect does water quality have on the marine environment?	72
C12. How can impacts of coastal development be minimised?	74
<b>Appendices</b>	<b>77</b>
Appendix 1 Sample tests	78
Appendix 2 Field work activities	85
Appendix 3 Laboratory work	110
Appendix 4 Classroom activities	130
Appendix 5 OHT or worksheet illustrations	210

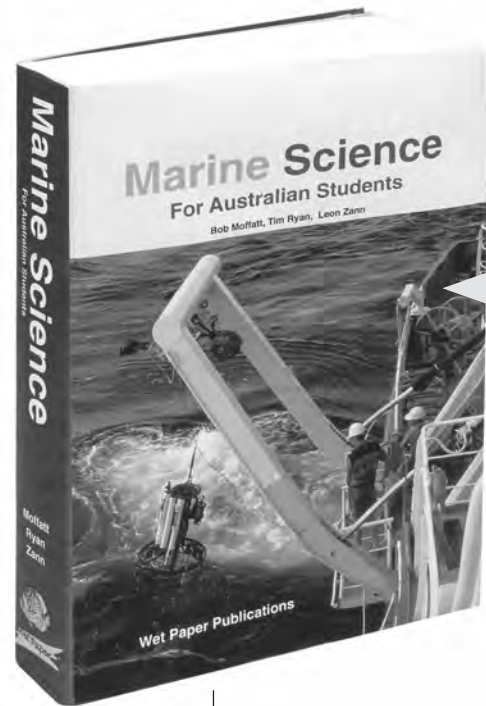
## Read this first

All information to answer the questions is contained in your textbook - *Marine Science for Australian Students* as shown in the Figure below.

- The aim of this enquiry based exercise book is to give you the opportunity to develop your knowledge and understanding of basic oceanography for further study either at university as a marine scientist or at TAFE as an interpretive tourist guide.
- The questions in this book are designed to help you practise answering different levels of literacy question (see page 591 of your textbook). For example harder questions have more challenging verbs such as *interpret*, *distinguish between* and *decide*, whereas easier questions will have verbs such as *name*, *state*, *label*, *list* or *complete*.

Your teachers can help you interpret and understand these verbs.

- To help get you started, key verbs have been underlined in Exercise A1 - What does the topography of the ocean look like?



Page 11

Answer to Q3.  
on page  
opposite

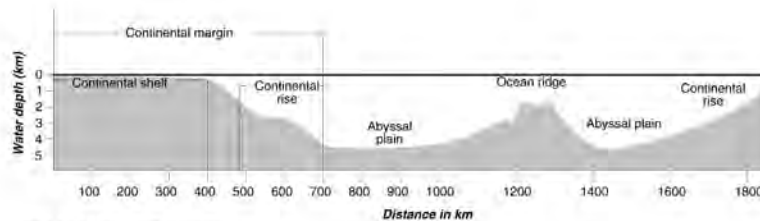


Figure 11.1 Ocean floor topography  
(Illustration from Mollart)

### Topography

The study of the shape of the land above and below the oceans is called **topography**. The ocean floor is divided into the continental margin, ocean-basin floor and mid-ocean ridges.

#### Continental margin

The **continental margin** (Figure 11.1) stretches out from the land as far as the eye can see. The average distance for the continental margin is 65 kilometres and its character varies from place to place. In Australia (Figure 11.2), it consists of the **continental shelf** (mostly fairly narrow), the **continental slope**, and the **continental rise**. In other parts of the world the continental margin can consist of a shelf, slope, deep-sea trench and a broad ridge.

#### Odd facts

- The earth's tallest mountain, longest mountain range and deepest canyon are all in the ocean.
- The surface of Venus - millions of kilometres away and hidden by clouds of sulphuric acid - has been better mapped than the earth's sea bed (The Economist, 3 September, 1994).
- The Great Meteor seamount (submarine volcano) in the North East Atlantic has a basal diameter of over 100 kilometres and a height of four kilometres (The Times Atlas of the Oceans).
- Australia's very own underwater Grand Canyons - the Murray Canyons are deeper than America's Grand Canyon and more than twice the height of Australia's highest mountain, Mt Kosciusko. Scientists drilled long cores into sediment around the Murray Canyons system that has been deposited over the centuries by the Murray Darling river system. This information will hopefully allow scientists to chart the history of oceans and climate in this region every 100 years for the past 250,000 years.

Ocean and coastline formation Page 11

Answer to Q4.  
on page  
opposite

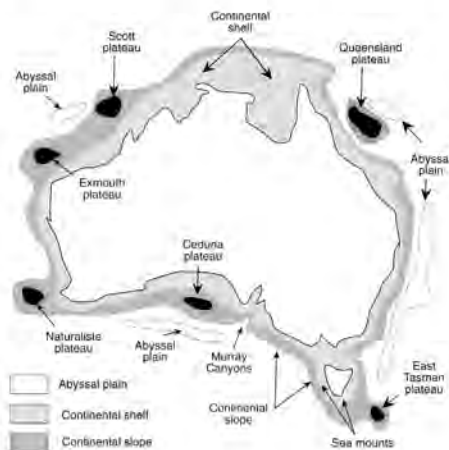


Figure 11.2 Australia's continental shelf  
(Illustration from Mollart, Ryan & Zann)

# Part A: Oceans

## A1. What does the topography of the ocean look like?

### Aim

- To explain ocean topography and relate it to Australia.

### What to do

- Read pages 7 - 11 of your textbook and answer the questions below.

### Questions

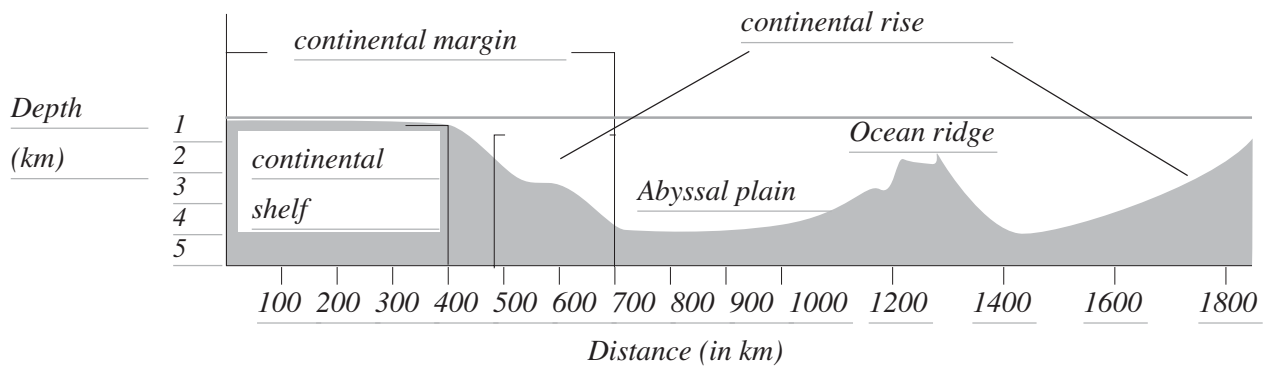
Q1. Describe how the world's oceans formed from the Earth's atmosphere.

*As the new atmosphere slowly cooled, it eventually reached a temperature at which water vapour and liquid could exist at the same time. The oceans were then formed.*

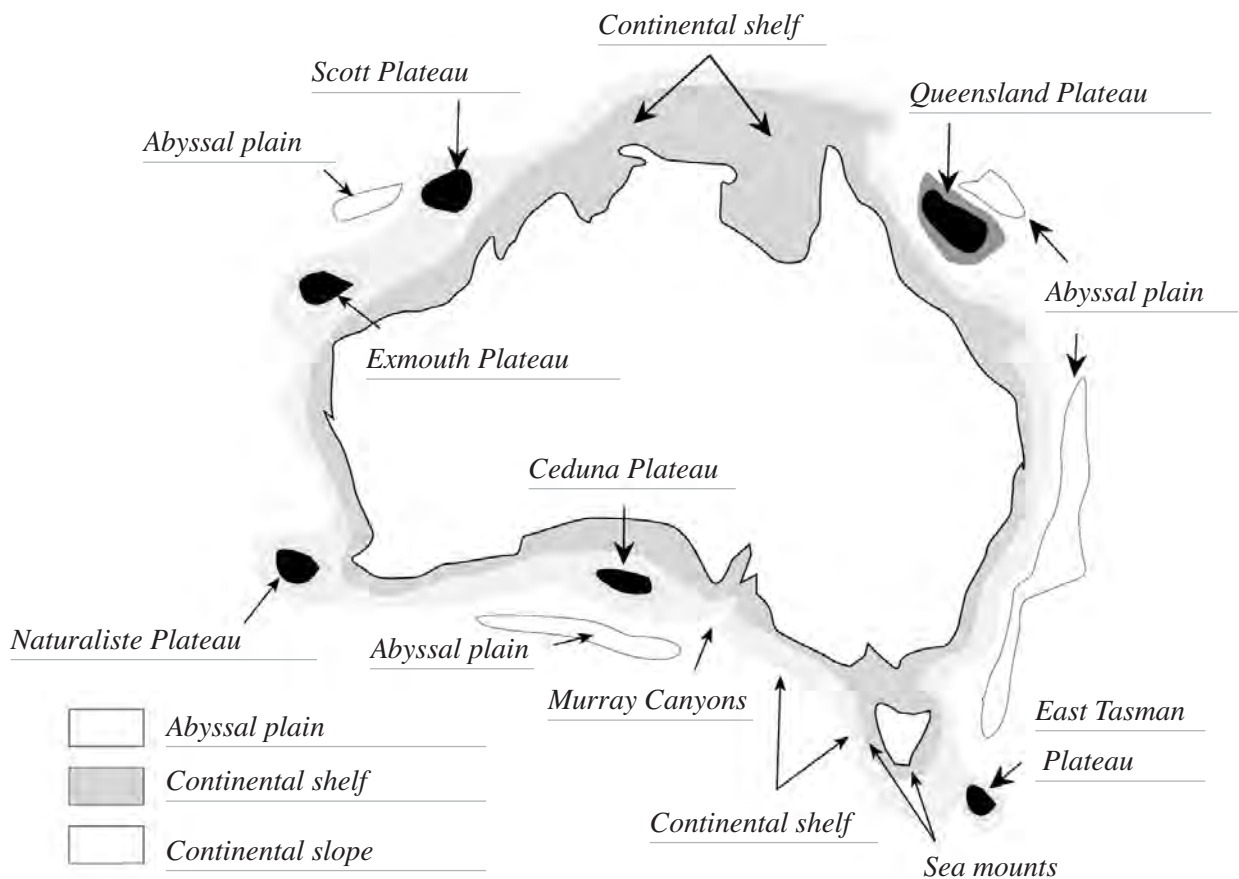
Q2. Recall the mean depth of the ocean. Compare the depth of the Mariana's Trench with the height of Mt. Everest.

*The mean depth is 3118 m but the deepest part, the Mariana's Trench in the Pacific Ocean, is 11 038 m deep. This trench dips further below sea level than Mt. Everest reaches above.*

Q3. Identify the main features of Figure 11.1 of your textbook by completing the illustration below.



Q4. Complete and colour in the figure below to identify the main features of Australia's continental shelf.



## A2. What part of the world oceans does Australia own?

### Aim

- To explain the sub surface geology that determines seabed ownership by Australia.

### What to do

- Read pages 12 - 13, 22 of your textbook and answer the questions below. Then search for the following URL <http://www.ga.gov.au/news/archive/2008/april> to answer Question 6.

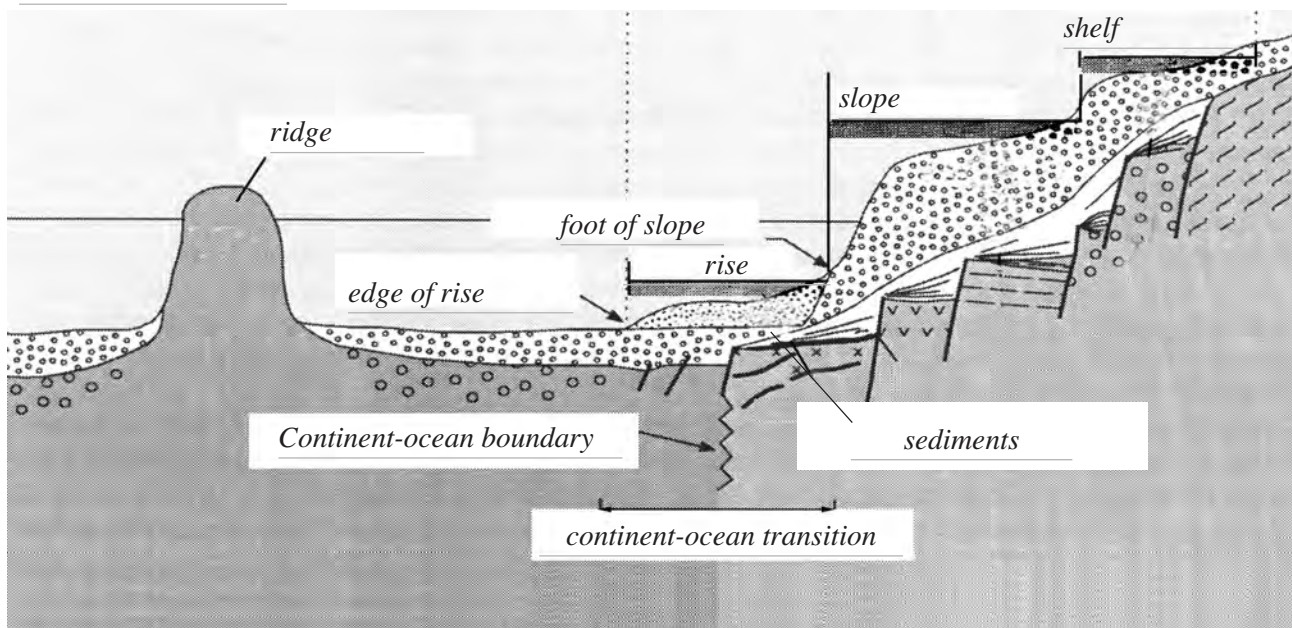
### Questions

- Q1. Name the parts of the continental shelf that make up the geomorphic margin of Australia.

*Rise, slope and shelf*

- Q2. Complete the diagram below to identify the following - *Sea level, ridge, edge of rise, continent-ocean boundary, continent-ocean transition, foot of slope, rise, slope, sediments and shelf.*

*Sea level*



- Q3. Study page 22 of your textbook. Explain how the sediments in the rise of the geologic margin occurred. Mark these in the diagram above.

*Erosion from mountain ranges and valleys caused sediments to flow over the continental shelf.*

- Q4. Study Figure 13.2 of your textbook and distinguish between the continental shelf and EEZ.

*Continental shelf - Sovereign rights for exploring and exploiting non-living resources of sea-bed and subsoil plus sedentary species.*

*Exclusive economic zone - Sovereign rights for exploring, exploiting, conserving and managing living and non-living resources of the water, sea-bed and sub-soil. Give access to surplus allowable catch.*

- Q5. Explain how a knowledge of subsurface geology of the continental slope is important to Australia.

*It allows us to claim the resources of our continent under the 1982 international*

*Law of the Sea Convention (UNCLOS).*

- Q6. Use the press release from the Geoscience Australia Web Site below and amend your textbook first edition page 435. <http://www.ga.gov.au/news/archive/2008/april>. Explain what changed in 2008?

*Australia's submission for jurisdiction over an additional 2.5 million square kilometres of seabed was confirmed by the United Nations Commission on the Limits of the Continental Shelf.*

### A3. What major geological movements have occurred in Australia?

**Aim**

- To explain the principles of plate tectonics and how this has affected what Australia looks like today.

**What to do**

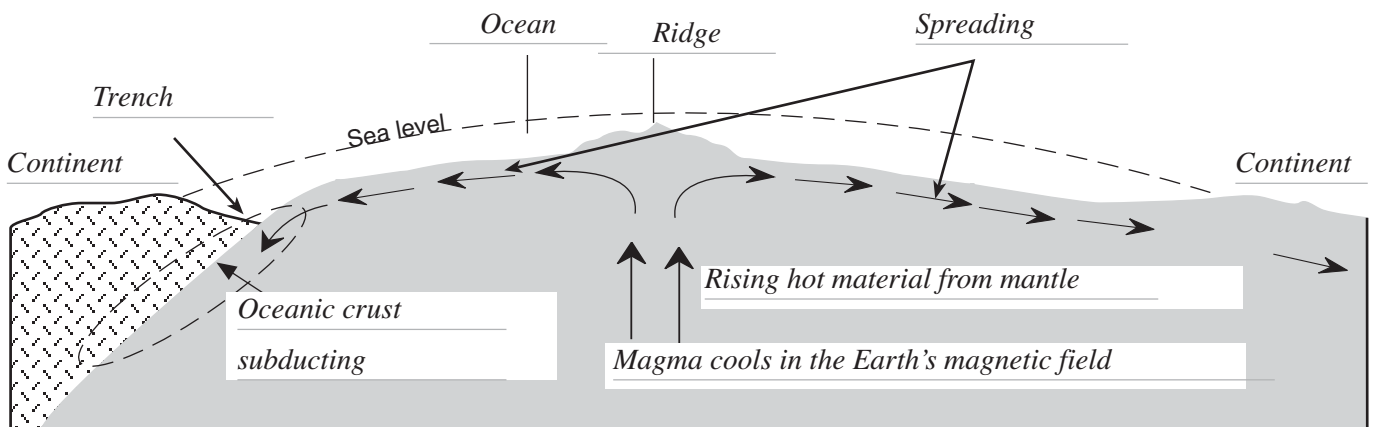
- Read pages 16 - 22 of your textbook and answer the questions below.

**Questions**

Q1. Interpret Figure 16.1 of your textbook and describe what happens in a mid ocean ridge.

*Hot magma rises from the Earth's core and pushes against the oceanic crust to form a ridge about 2.5 km deep. This pushes the plates apart.*

Q2. Complete the diagram below to show how sea floor spreading occurs.

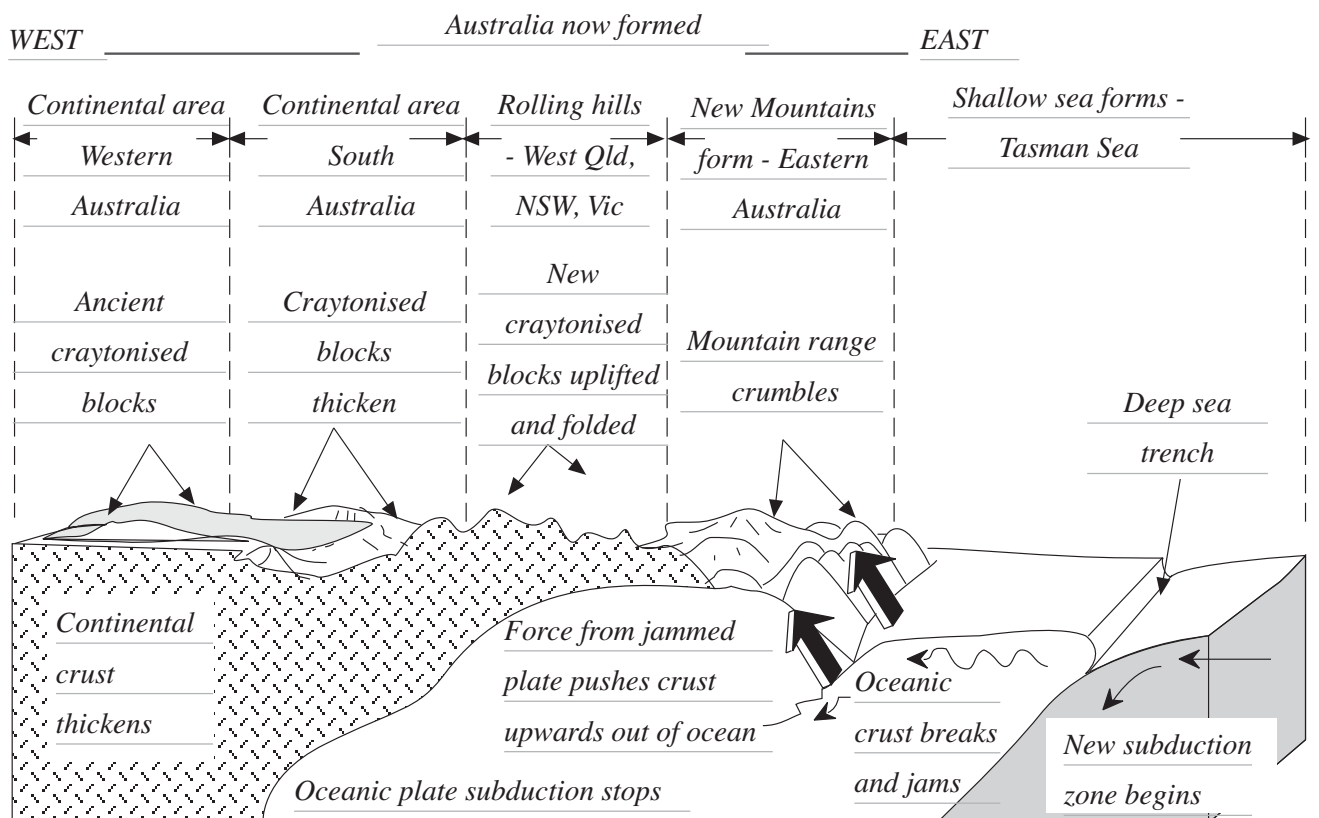


Q3. Describe what happens when oceanic crust collides with continental crust.

*Subducting, mountain building, trench formation in the ocean*

*Volcanoes and earthquakes*

Q4. Complete the figure below to illustrate what has happened in Australia as a result of plate tectonics. Identify where you live.



#### A4. What happened in ice age Australia?

##### Aim

- To explain what happened to our nearby oceans during the ice age and how reefs were formed today.

##### What to do

- Read pages 23 - 25 of your textbook and answer the questions below.

##### Questions

- Q1. Recall what happened geologically to Australia 50 million years ago.

*Australia separated from Antarctica and had begun its journey northward into warmer waters where it was later to rejoin with Asia.*

- Q2. Summarise what happened to Queensland off shore islands and reefs 18 million years ago to present day. Complete the illustrations A - D opposite to illustrate your answer.

*A: Corals began to grow when Australia reached the lower latitudes.*

*B: As ice caps melted, rising waters in the tropics meant conditions were right for coral growth. Life abounded in the seas and the islands were surrounded by water.*

*Populations of birds may have developed because of the absence of natural predators such as snakes or dingoes. Turtles could nest and form rookeries also with the absence of larger predators.*

*C. A series of ice ages meant that the sea level fell.*

*Continental shelf areas were subjected to river systems and erosion. The limestone caves under and around old limestone cliffs were possibly the homes for our early Aborigines. Trees and shrubs grew and kangaroos hopped around.*

*D. About 18,000 years ago the ice caps from the last ice age began to melt and water level gradually rose. With the rising waters more coral grew, forming a thin layer over the old fossil reefs. Gradually this layer increased to a thickness of 15 metres.*

*The major part of a coral reef is non-living limestone and the living plants and animals only form a veneer on its surface. On the reefs we see today are layers of new coral growth, about 15 metres deep, covering the old fossil reefs.*

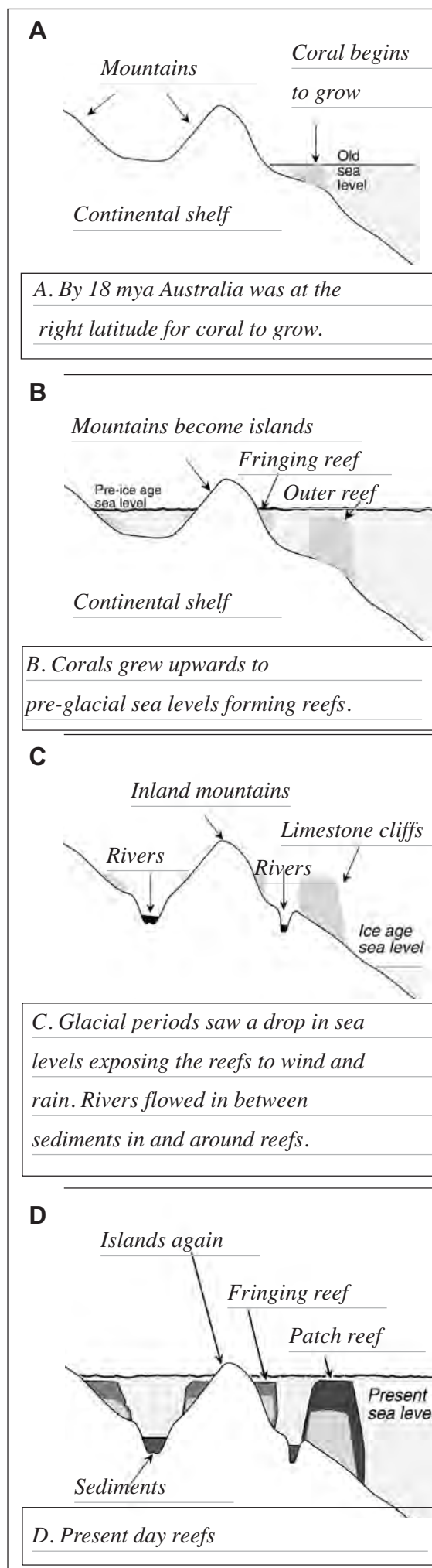


Figure 8.1



Q3. Recall what happened in Western Australia geologically and what was formed 50 million years ago. What happened elsewhere in Australia?

*A great rift occurred causing the Darling fault. These rifts also occurred in the Great Australian Bight, through South Australia and extending to the Great Ocean Road in Victoria.*

Q4. Describe what happens to coastlines during an ice ages.

*When an ice age occurs, vast amounts of water become trapped in the polar ice caps and the depth of the ocean decreases. Shallow seas drain and land bridges form that allows movements of human populations as well as other animal and plant life.*

Q5. Describe how the authors of *Range to Reef*, explain the evolution of the coastal zone in Western Australia. Identify the numbers 1 - 9 in the illustration below to explain their answer.

*Ten million years ago, the north west corner of Australia was covered by a shallow sea.*

*Later the crust of the earth crumpled and a huge anticline rose to form Cape Range Peninsula.*

*The back bone of the range is hard fossil bearing limestones, laid down on the sea-floor in those earlier times. The western side of the peninsula exhibits four distinct terraces.*

*Fringing reef in Western Australia can be found as close to shore as 100 metres and as far out as a few kilometres.*

*1. Reef front slope*

*2. Modern reef*

*3. High tide*

*4. Lagoon*

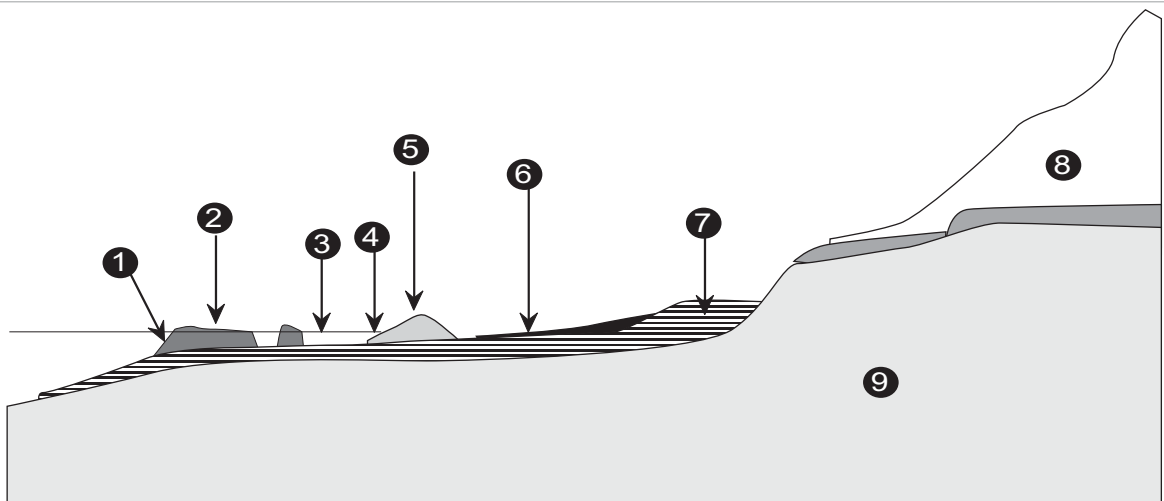
*5. Recent dunes*

*6. Coastal plain*

*7. Sediments of the last reef-forming period*

*8. Ice age terraces*

*9. Older limestone*



## A5. What is climate change and how does it affect the ocean?

### Aim

- To interpret climate change graphs and explain how the oceans are becoming more acidic.

### What to do

- Read page 446 of your textbook and the page opposite to answer the questions below.

### Questions

Q1. Write a definition for the enhanced greenhouse effect.

*The greenhouse effect is the process in which the emission of increased infrared radiation by the atmosphere warms a planet's surface*

Q2. State which human actions increase greenhouse gases.

*Burning fossil fuels (coal, oil and natural gas), agriculture and land clearing*

Q3. Recall the major reason for sea level rise.

*Thermal expansion - as the Earth's sea temperature rises - it expands.*

Q4. Define the term climate change in terms of average weather.

*Climate change is any long-term significant change in the "average weather" that a given region experiences. Average weather may include average temperature, precipitation and wind patterns.*

Q5. Recall the statement that says "warming of the climate system is unequivocal" and three justifications for it.

*Recent finding of the Intergovernmental Panel on Climate Change stated that -*

*"Warming of the climate system is unequivocal, as is now evident from (1) observations of increases in global average air and ocean temperatures, (2) widespread melting of snow and ice, and (3) rising global average sea level."*

Q6. Interpret the graph on Earth's temperature 1000 - 2100 on the next page.

*The prediction is that the Earth's temperature could increase between 1.1 and 6.6 degrees in the next 90 years.*

Q7. Interpret the graph of future scenarios for sea level rise on the next page.

*The prediction is that the seas could rise from between 0.1 and 0.6 metres*

Q8. Describe the effect of increased carbon dioxide on ocean acidity.

*Carbon dioxide emitted to the atmosphere by human activities is being absorbed by the oceans, making them more acidic.*

Q9. Recall the change in pH units over the past 200 years.

*Evidence indicates that emissions of carbon dioxide from human activities*

*over the past 200 years have already led to a reduction in the average pH of surface seawater of 0.1 units and could fall by 0.5 units by the year 2100.*

Q10. Summarise possible effects of ocean acidification and global warming on marine organisms and Earth ecosystems.

*This pH is probably lower than has been experienced for hundreds of years and, critically, at a rate of change probably 100 times greater than at any time over this period. Impacts on oceans will be greater for some regions and ecosystems, and will be most severe for coral reefs and the Southern Ocean.*

*Coral bleaching, the change in location of marine species or timing of reproductive activities.*

*This change in timing in seasons may be a precursor to localised extinction for some species.*

## Climate change

Thanks to Craig Reid, Mirani SHS, for his help in providing information for this article.

### Enhanced greenhouse effects

Greenhouse gases are a natural part of the atmosphere. They absorb and re-radiate the Sun's warmth, and maintain the Earth's surface temperature at a level necessary to support life. The problem we now face is that human actions- particularly burning fossil fuels (coal, oil and natural gas), agriculture and land clearing are increasing the concentrations of the gases that trap heat. The enhanced greenhouse effect is the process by which increased man made emissions trap a greater amount of infrared radiation within the atmosphere causing the planet's surface to warm (Figure 11.1).

Water vapour is the most abundant greenhouse gas. Its concentration is highly variable and human activities have little direct impact on its amount in the atmosphere. Humans have most impact on carbon dioxide, methane and nitrous oxide. Various artificial chemicals such as halocarbons also make a small contribution to the enhanced greenhouse effect.

In addition to warming of the Earth's surface, there has been an increase in heatwaves, warming of the lower atmosphere and deep oceans, fewer frosts, retreat of glaciers and sea ice and a rise in sea level during the 20th century of about 17 cm.

### Global warming

During the past 100 years, global average surface temperature increased by about 0.7°C, (Figure 11.2). Tree rings and other records tell us that average Northern Hemisphere temperatures during the second half of the 20th century were likely to have been the highest in at least the past 1300 years.

### How much warming is likely this century?

As the Earth's surface warms, the oceans slowly absorb heat and expand, causing the sea level to rise (see Figure 11.3). This **thermal expansion** of the ocean will be a major contributor to sea level rise during future centuries.

### Climate change

Climate change is any long-term significant change in the "average weather" that a given region experiences. Average weather may include average temperature, precipitation and wind patterns. It involves changes in the variability or average state of the atmosphere over durations ranging from decades to millions of years. These changes can be caused by dynamic processes on Earth, external forces including variations in sunlight intensity, and more recently by human activities. The Intergovernmental Panel on Climate Change - an international body that assesses the latest science of climate change - has stated that "*Warming of the climate system is unequivocal, as is now evident from observations of increases in global average air and ocean temperatures, widespread melting of snow and ice, and rising global average sea level.*"

### Earth ecosystems

Many species of plants and animals have changed their location or the timing of reproductive activities in ways that provide further evidence of climate change. This change in timing in seasons may be a precursor to localised extinction for some species.

### Ocean acidification

Carbon dioxide emitted to the atmosphere by human activities is being absorbed by the oceans, making them more acidic. Evidence indicates that emissions of carbon dioxide from human activities over the past 200 years have already led to a reduction in the average pH of surface seawater of 0.1 units and could fall by 0.5 units by the year 2100. This pH is probably lower than has been experienced for hundreds of millennia and, critically, at a rate of change probably 100 times greater than at any time over this period. Impacts on oceans will be greater for some regions and ecosystems, and will be most severe for coral reefs and the Southern Ocean. The impacts of **ocean acidification** on other marine organisms and ecosystems are much less certain.

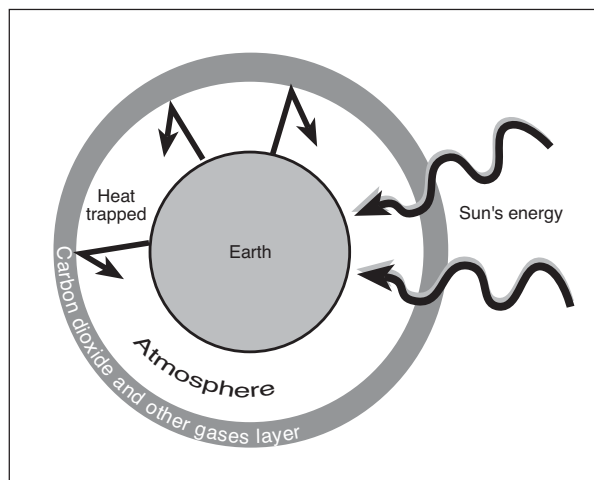


Figure 11.1 Greenhouse effect

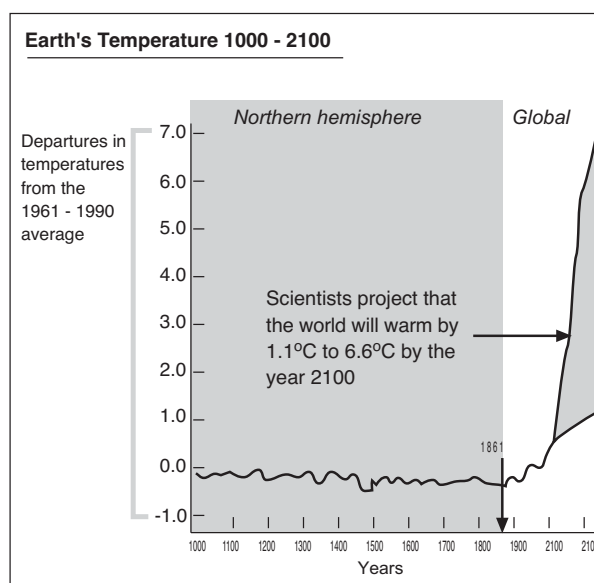


Figure 11.2 Past 100 years, global average surface temperature

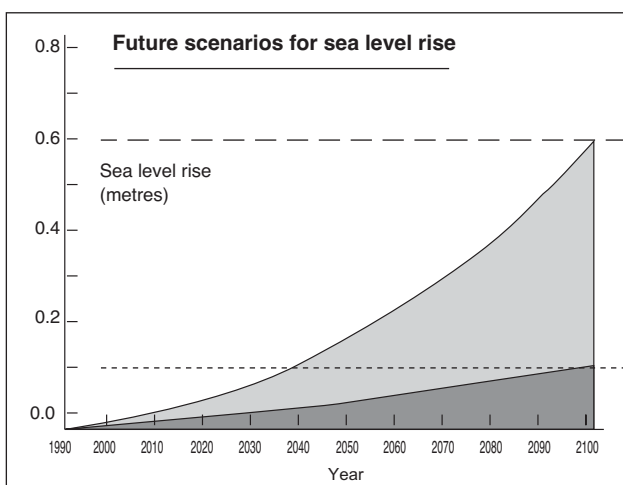


Figure 11.3 Sea level rise

## A6. How do ocean currents form?

### Aim

- To describe how the Sun and Earth's rotation causes currents.

### What to do

- Read pages 59 - 62 of your textbook and the page opposite to answer the questions below.

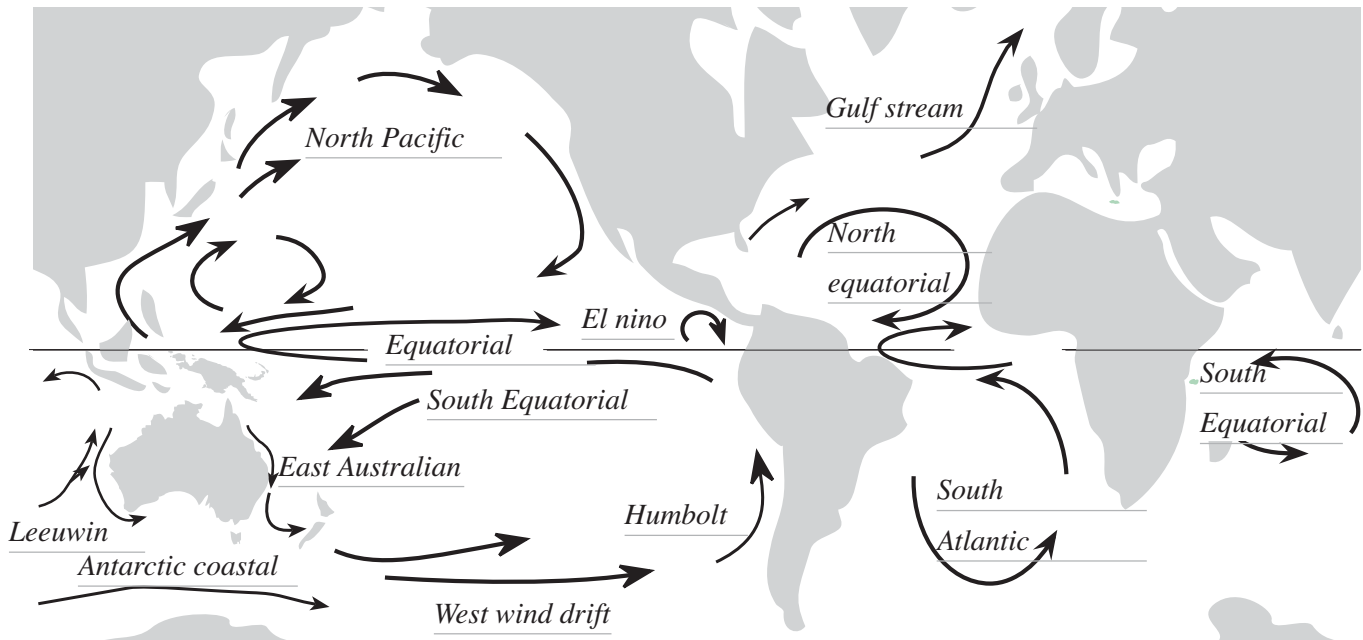
### Questions

Q1. Explain the two effects the sun has on ocean currents.

*First, it heats the atmosphere, creating winds and moving the sea surface through friction. This sets up the trade winds creating the large ocean currents.*

*The second is to alter the density of the ocean surface water directly by changing its temperature and/or its salinity. This can result in the water column becoming unstable, setting up density-dependent currents,*

Q2. Complete the map of the world below marking in the Pacific, Atlantic and Indian Oceans and identifying the following currents - North Pacific, El Niño, Leeuwin, Antarctica, West wind drift, Humbolt, East Australian, Gulf Stream, Equatorial, North Equatorial, South Equatorial, South Atlantic.



Q3. Explain how thermohaline circulation occurs, state what it controls and explain what it is responsible for.

*Thermohaline circulation occurs when cold water sinks at the poles and warm water rises at the equator*

*Thermohaline circulation controls the vertical distribution of temperature and salinity in oceans*

*It is responsible for vertical water movements that ventilate deep ocean water masses in a large scale oceanic circulation called the ocean conveyor belt.*

Q4. Define the term geostrophic current and explain their significance for Australia.

*They are currents caused by a sloping sea surface and create regions of different pressure.*

*They are significant because they push large amounts of water towards Australia.*

Q5. Describe how the Earth's rotation can cause currents to move.

*It causes currents to flow clockwise in the northern hemisphere and anticlockwise in the southern hemisphere. This sets up large oceanic gyres.*

Q6. Define the term Coriolis force.

*It is the force that drives water faster as it moves away from the equator.*

## Ocean currents

Ocean currents are driven by two forces: the Sun and the rotation of the Earth.

### A. The sun

The Sun affects the ocean in two ways.

First, it heats the atmosphere, creating **winds** and moving the sea surface through friction. These moving air cells are called **trade winds** and blow in one prevailing direction, depending on their latitude (Figure 13.1). The boundary between the two sets of trade winds is usually slightly north of the equator. The trade winds set up two westward-flowing currents north and south of the equator (the North and South Equatorial Currents), but because the southeast trades blow across the equator, this causes a divergence (upwelling) along the equator itself.

The second effect of the Sun is to alter the **density** of the ocean surface water directly by changing its temperature and/or its **salinity**. If water is cooled or becomes saltier through evaporation, it becomes denser. This can result in the water column becoming unstable, setting up density-dependent currents, also known as the **thermohaline circulation** (Figure 13.2). The term thermohaline circulation (THC) refers to the part of the large-scale ocean circulation that is thought to be driven by global density gradients created by surface heat and freshwater fluxes.

The thermohaline circulation is sometimes called the ocean conveyor belt, the great ocean conveyor, or the global conveyor belt (Figure 13.3)

Thermohaline circulation controls the vertical distribution of temperature and salinity in oceans, and is responsible for vertical water movements that ventilate deep ocean water masses.

Because the oceans are neither infinitely wide nor constantly dense, complications arise at the boundaries, where water tends to "pile up." The surface of the ocean is then no longer flat, but has a slope, which sets up a horizontal pressure gradient.

Just like turning on a fan at one end of the bathtub to make the water pile up at the other end, easterly trade winds push large amounts of warm water across the Pacific.

These currents caused by the sloping sea surface are called **geostrophic currents (sometimes geotrophic)**.

Because the density of the ocean varies both horizontally and vertically, scientists can use the density structure of the ocean to calculate the pressure field and hence the pressure gradient.

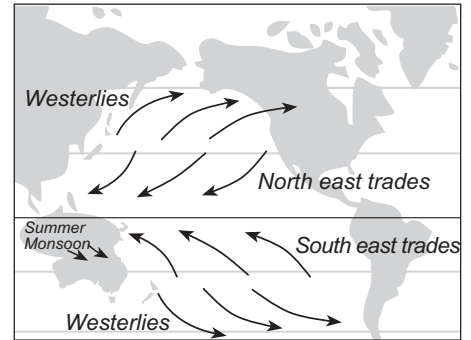


Figure 13.1 Trade winds

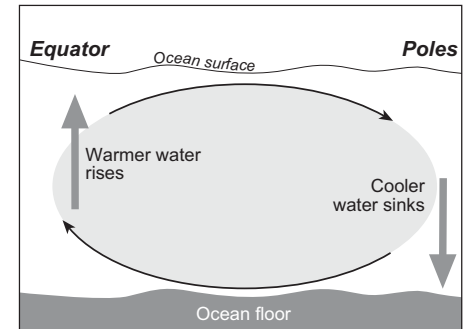


Figure 13.2 Thermohaline circulation (may vary summer to winter)

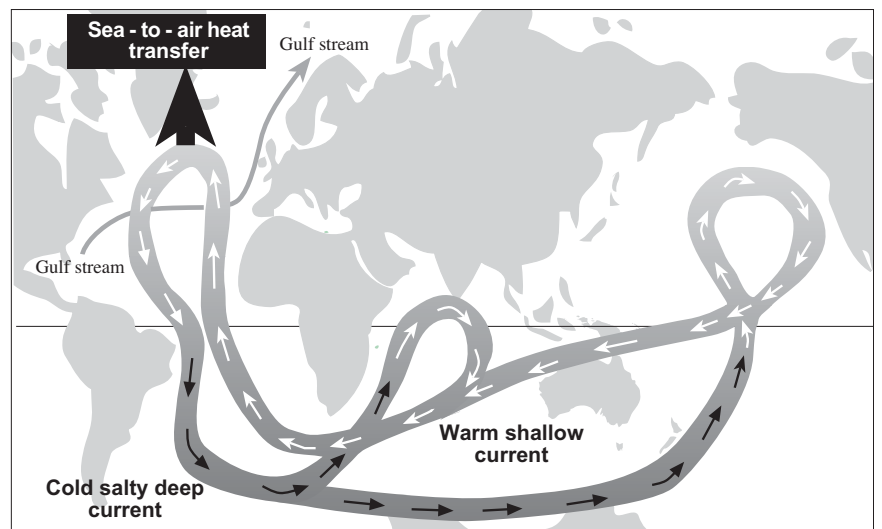


Figure 13.3 The global conveyor belt

### B. The rotation of the Earth

Because the spinning Earth is shaped like a ball, particles of water move faster as they move away from the equator.

The force driving these particles faster is called the **Coriolis force**.

The Coriolis Force is due to the Earth's rotation. This force causes moving objects (ie, water particles, air, planes, birds, etc) to deflect to the right of their motion in the Northern Hemisphere and to the left in the Southern Hemisphere. The Coriolis Force is strongest near the poles and zero at the equator.

#### Coriolis force

Particles of water move faster as they move away from the equator

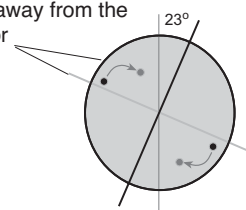
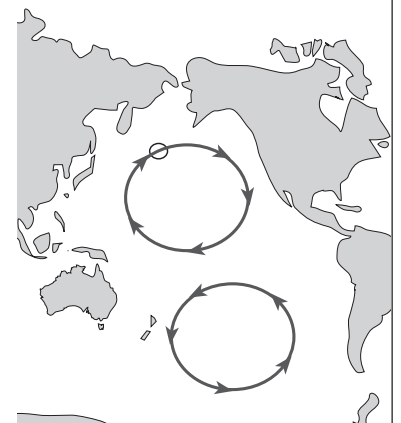


Figure 13.4 The Coriolis effect on surface currents  
(Illustration Bob Moffatt)



## A7. How does the El Niño current affect thermoclines in the sea?

### Aim

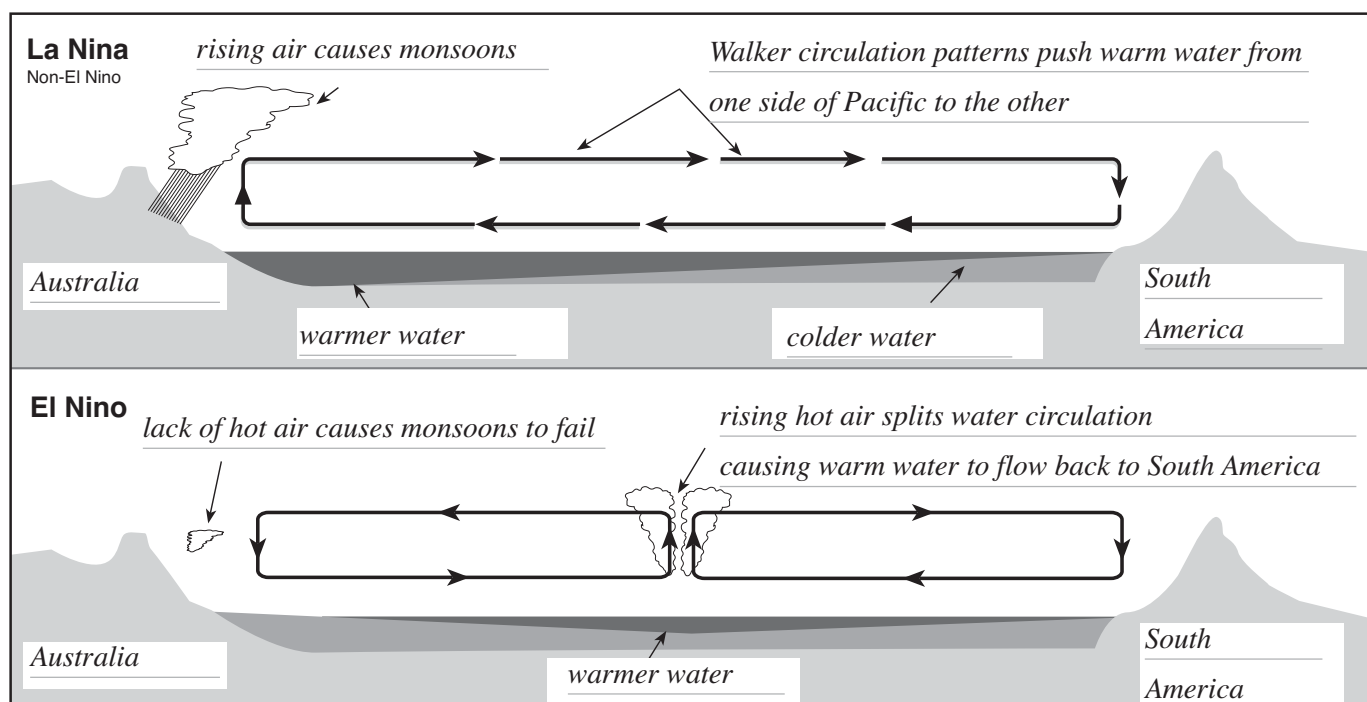
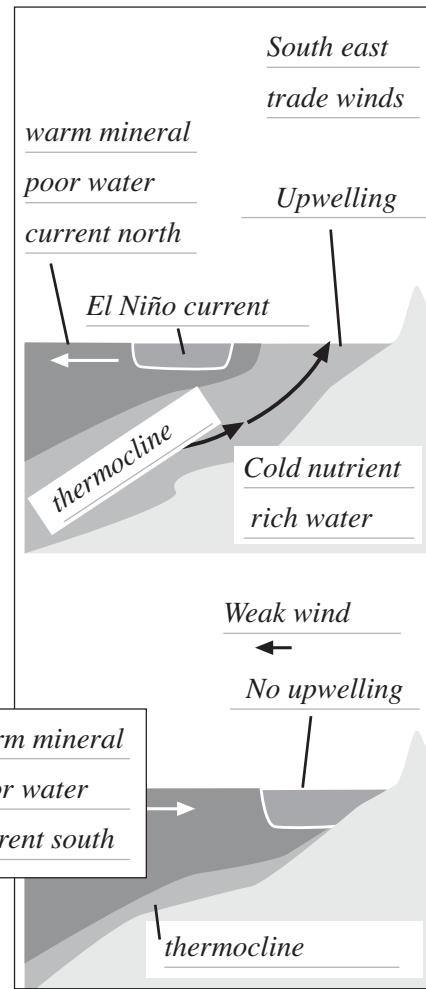
- To describe the El Niño effect on Australia.

### What to do

- Read pages 63-64 of your textbook and answer the questions below.

### Questions

- Q1. Complete the illustrations on this page illustrating how El Niño affects thermoclines in the sea.
- Q2. Describe the walker circulation in the Pacific Ocean.  
*The Walker circulation is the name given to the way that trade winds circulate air to and fro across the Pacific Ocean.*
- Q3. Explain how the monsoon occurs in Northern Australia.  
*Trade winds drive oceanic air west across the ocean to Indonesia and Australasia where the damp warm air forms monsoon rain patterns.*
- Q4. Explain what happens when the walker circulation is split and what happens to westward push on the ocean surface.  
*The push on the ocean surface falls and warm water that was once driven westward now runs back towards the central Pacific. This disrupts the ocean-atmosphere system causing hot air to rise and split the Walker circulation pattern.*
- Q5. Describe what happens to the El Niño current in Peru.  
*In the eastern Pacific, a branch of the Peru current breaks off, stopping cold water from entering upper layers of oceanic water.*



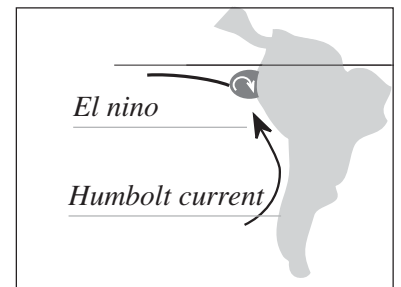
## A8. What effect does El Niño cause?

### Aim

- To describe and explain El Niño effects on Australia and Peru.

### What to do

- Read pages 63 - 64 of your textbook, the “read this” on the bottom of this page to answer the questions below.



### Questions

- Q1. Mark in the Humbolt and El Niño currents in the diagram above.
- Q2. Define the term atmospheric pressure.  
*Air pressure or atmospheric pressure is the force of the Earth's atmosphere.*
- Q3. Explain how atmospheric pressure varies on the Earth's oceans.  
*Varies according to location of high and low pressure systems*
- Q4. Define the SOI or Southern Oscillation Index in terms of air pressure calculations.  
*The Southern Oscillation Index (SOI) is calculated from the monthly or seasonal fluctuations in the air pressure difference between Tahiti and Darwin.*
- Q5. Answer true or false to the following statements.
- [ T ] Thermoclines off Peru make ideal conditions for phytoplankton, a rich food source for larger fish.
  - [ F ] Scientists know everything there is to know about El Niño.
  - [ T ] Sustained negative values of the SOI often indicate El Niño episodes.
  - [ F ] Negative values of the SOI are associated with stronger Pacific trade winds and warmer sea temperatures to the north of Australia.
  - [ T ] A moderate La Niña developed slowly during 2007.
  - [ F ] Waters in the central and eastern tropical Pacific Ocean become warmer during La Niña.
  - [ T ] El Niño can cause the Australian monsoon to fail.
- Q6. Explain why bushfires and droughts are more prevalent during El Niño events.  
*Because less wind blows across Australia, so less rain falls and summer temperatures can soar.*
- Q7. Explain why El Niño events cause such dramatic effects in Peru.  
*The warm current comes close to shore and cuts off the nutrient rich upwellings*  
*The plankton population drops dramatically causing the anchovy fishery to fail and decreased marine species populations*
- Q8. Negative El Niño values are usually accompanied by -
- a. sustained warming of the central and eastern tropical Pacific Ocean.
  - b. a decrease in the strength of the Pacific Trade Winds.
  - c. a reduction in rainfall over eastern and northern Australia.
  - d. All of the above are correct.

### Read this

From [www.bom.gov.au](http://www.bom.gov.au)

Sustained negative values of the SOI often indicate El Niño episodes. These negative values are usually accompanied by sustained warming of the central and eastern tropical Pacific Ocean, a decrease in the strength of the Pacific Trade Winds, and a reduction in rainfall over eastern and northern Australia. Severe droughts resulted from the weak to moderate El Niño events of 2002/03 and 2006/07.

Positive values of the SOI are associated with stronger Pacific trade winds and warmer sea temperatures to the north of Australia, popularly known as a La Niña episode. Waters in the central and eastern tropical Pacific Ocean become cooler during this time. Together these give an increased probability that eastern and northern Australia will be wetter than normal. The most recent strong La Niña was in 1988/89. A moderate La Niña developed slowly during 2007.

## A9. What is so special about the EAC?

### Aim

- To describe features of the East Australian Current.

### What to do

- Read pages 64 - 65 of your textbook, and answer the questions below.

### Questions

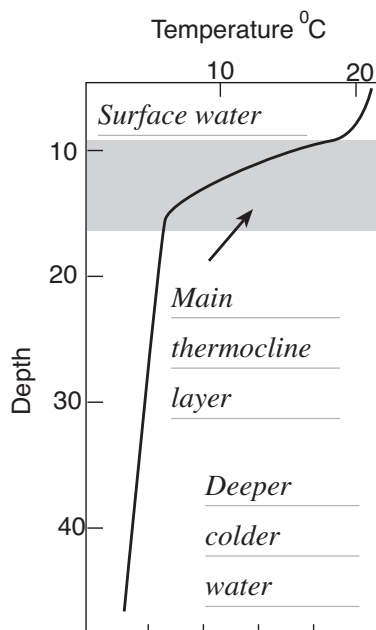
- Q1. Name the person who discovered the East Australian current and explain how it was discovered.  
*Captain James Cook when he was just east of Byron Bay in 1770. He found that for two days he was actually sailing backwards and realised that he had sailed into a strong current from the north.*
- Q2. Explain what instruments were used by the CSIRO Marine Division to discover that the current does not flow in one direction.  
*They used a series of tracker buoys, satellites and ships.*
- Q3. Name and describe the circulating bodies of water off the East Australian coast.  
*Eddies. These are large circulating bodies of water.*
- Q4. Explain why the Coral Sea is almost a metre higher than Bass Strait.  
*Because Bass Strait is colder, water tends to sink. The water will then tend to flow to a lower level causing geotrophic currents.*
- Q5. State where upwellings occur in the EAC and how they help the fishing industry.  
*The upwellings occur in the triangle between the coast and the eddy. They help the fishing industry by bringing up nutrients from waters on the continental shelf. The nutrients provide food for animals in the food chain which sustain the fish caught by fisherman.*
- Q6. State temperature and colour differences in these upwelling areas.  
*The waters can be up to 5°C colder and the water a dirty brown.*

### Extension

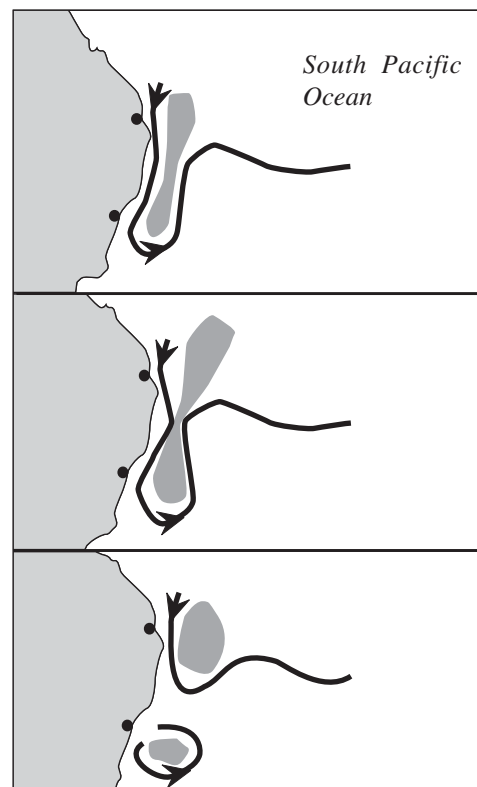
In the film - *Finding Nemo*, Marlin took three weeks to get to Sydney in the EAC. Calculate the average speed of the current based on this information.

- Q7. Use the following definition to complete the illustration below.

*A thermocline is a layer within a body of water or air where the temperature changes rapidly with depth.*



- Q8. Complete the following diagram to show how and where an eddy forms in the EAC.





## A10. What is so special about the Leeuwin current?

### Aim

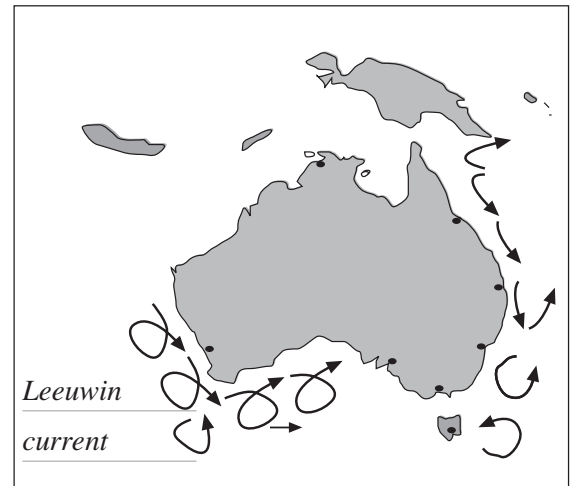
- To explain the importance of studying the Leeuwin current.

### What to do

- Read pages 66 - 67 of your textbook, and answer the questions below.

### Questions

- Q1. Mark in the Leeuwin current and eddies in the map of Australia to the right.
- Q2. Describe the current in terms of where it is found, where it starts, where it finishes, when it moves and water densities involved.



Where found, where starts and finishes.

Western Australia and starts in the warm, low-salinity waters off the north-west coast finishes in South Australia.

When it moves and water densities involved.

Moves south from February to June, and is found off Perth in April.

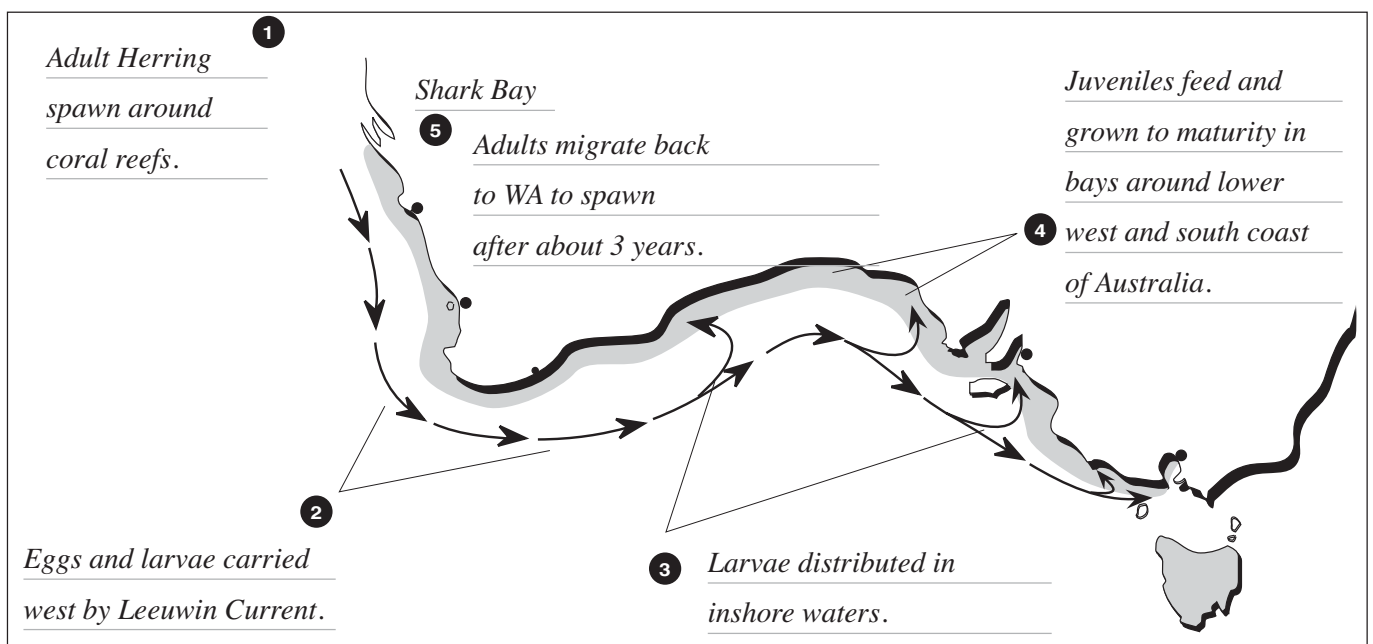
Less dense water causes the sea level to rise a height of about 30cm. The water will then tend to flow to a lower level causing geotrophic currents. It flows southward to Cape Leeuwin and east across the Great Australian Bight.

- Q3. Justify why the Australian herring and blue finned tuna need this current to survive. Complete the diagram below to illustrate your answer.

The current brings juvenile southern blue fin tuna south along the coast of Western Australia from their spawning ground off the northwest of the continent.

Herring larvae grow up in the warm waters around Shark Bay and then, within a few months, are found almost one-third of the way around Australia in the ocean off Adelaide and Melbourne.

As the current slows, the larvae make their way into estuaries and bays where they grow into juveniles and feed off the rich plankton waters in the southern ocean. When they are mature, they migrate back to Western Australia.



## A11. When do Australian ocean sea temperatures change?

### Aim

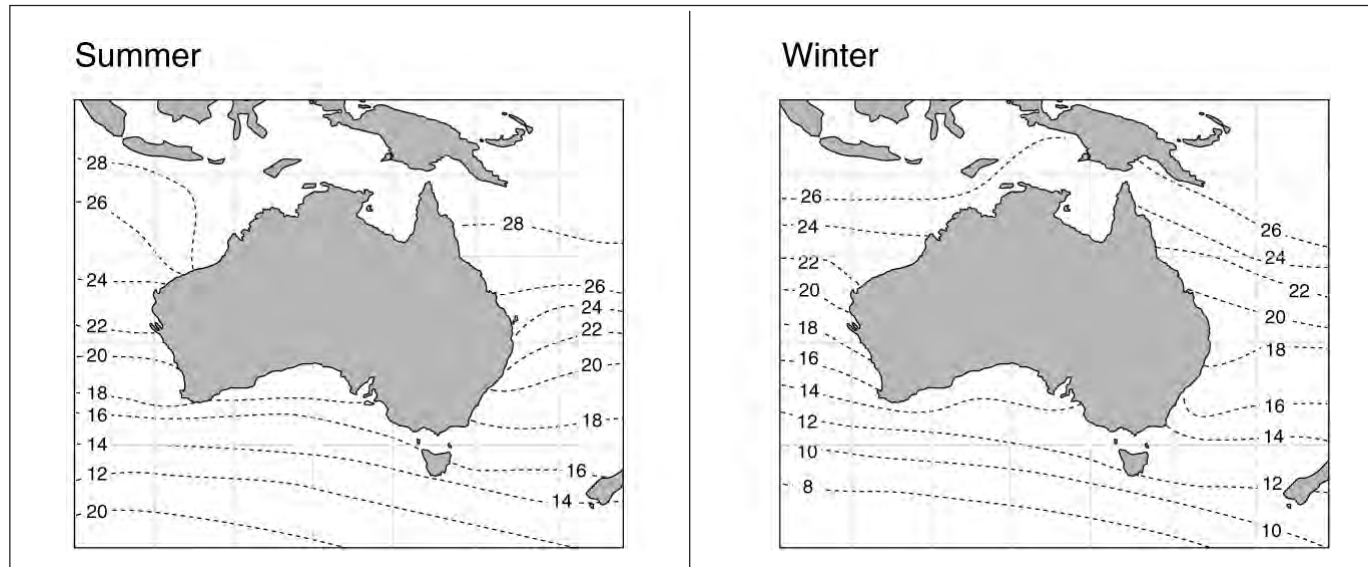
- To compare Australian summer and winter sea surface temperatures.

### What to do

- Read page 77 of your textbook, interpret Figure 77.1 and answer the questions below.

### Questions

Q1. Complete the maps below to show the difference between Australian summer and winter sea temperatures.



Q2. Identify the seawater temperatures for a position 30 km off the coast in February at the following places:

- |              |      |              |      |
|--------------|------|--------------|------|
| a. Brisbane  | 24°C | b. Sydney    | 20°C |
| c. Melbourne | 18°C | d. Hobart    | 16°C |
| e. Perth     | 20°C | f. Shark Bay | 24°C |
| g. Broom     | 28°C | h. Darwin    | 28°C |

Q3. State the coldest sea temperatures in August and name where were these are found in Australia.

14°C, off Victoria's southern coast.

Q4. Explain why the waters in the Spencer Gulf are 20°C, yet off the Kangaroo Island they are 18°C in February.

The Water in Spencer Gulf is closer to the coast, and is warmed by the land.

Q5. The lines joining sea temperatures flow southward down the Western Australian coast to Perth. Suggest a reason for this phenomenon.

The Leeuwin current carries warm water south.

Q6. Propose a reason for the fact that the seawater temperatures at the same latitude are not always the same.

Ocean currents, the presence of land masses.

Q7. Explain the change that occurred between February and August. Suggest a reason for the change.

Warmer water extends further south in summer, due to warmer weather, and the southern hemisphere being oriented closer to the sun.

Q8. Explain why shipwreck survivors can survive up to 40 hours in the waters off Brisbane but only 6 hours off southern Tasmania.

Water off the coast of Brisbane is 6-8°C warmer than the water off Tasmania.

Hypothermia would kill people in colder waters.

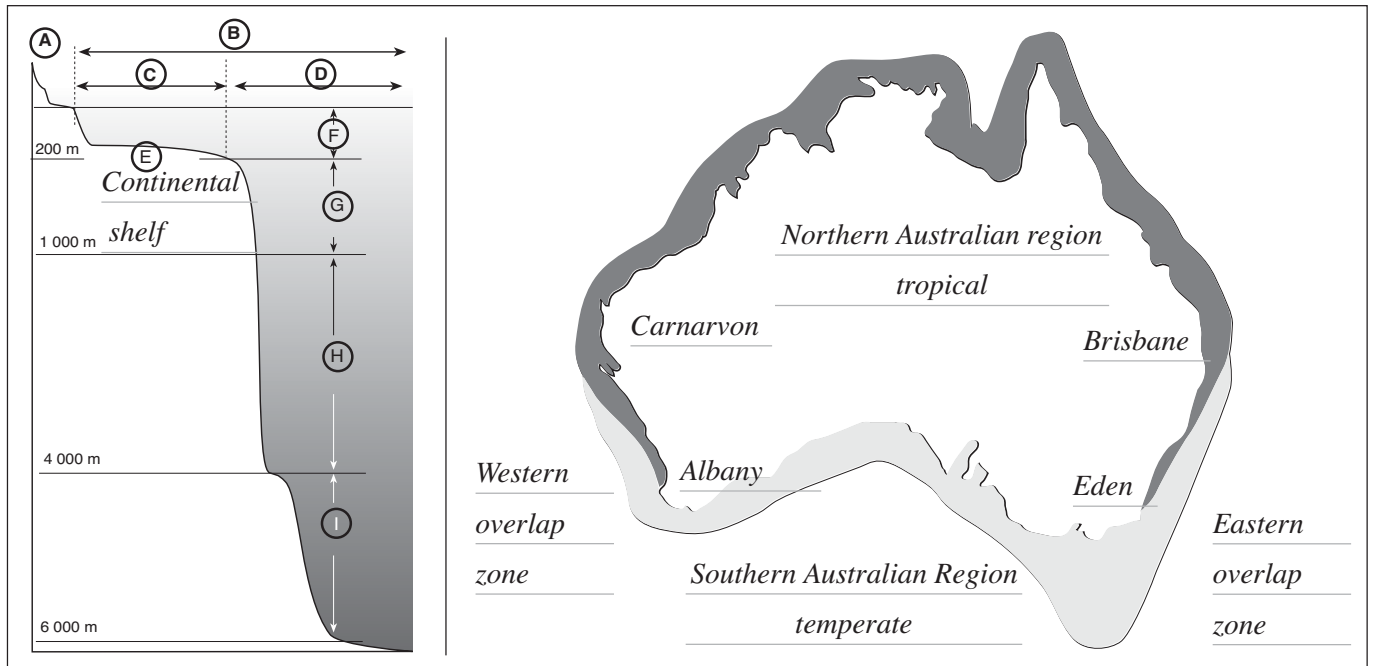
## A12. How is marine life in Australia governed by ocean temperature?

### Aim

- To identify Australian marine habitats and compare bioregions that are governed by temperature.

### What to do

- Read pages 210 - 211, 218, 490 of your textbook and answer the questions below.



### Questions

Q1. Identify the letters A - I on the figure above. Mark in the continental shelf on the left illustration.

*A: Intertidal zone B: Pelagic zone C: Neretic D: Oceanic F: Upper pelagic*

*G: Middle pelagic H: Lower Pelagic I: The abyss*

Q2. Define the term marine biogeography.

*The study of the distribution of marine life on earth.*

Q3. Distinguish between the different bioregions in Australia by using colours in the map above.

Q4. Recall the temperature boundary of Australian marine provinces and what could vary these boundaries.

*The boundary between the tropical and warm temperate provinces coincides approximately with 18-20°C winter minimum surface temperature. This is variable and dependant on the influence of the East Australian Current and the Leeuwin Current.*

Q5. Describe differences between northern and southern regions by completing the table below.

Northern Australian Region	Southern Australian Region
<i>Open shores in northern Australia are typified by extensive growths of coral reefs. Sheltered shores support over 30 species of mangrove and have little salt marsh vegetation. Northern coral reefs have a high diversity of fish and invertebrates. However, only 10% to 15 % of northern Australian marine species are endemic</i>	<i>Rocky shores in southern Australia are typified by extensive growths of massive brown seaweeds, called kelps. Sheltered shores support extensive salt marshes and only one species of mangrove. These shores have the world's highest diversity of seaweeds and some invertebrate groups. 80% to 90% of southern Australian marine species are endemic.</i>

### **A13. What causes Tsunamis?**

#### **Aim**

- To understand the issues associated with Tsunamis.

#### **What to do**

- Read page 52 of your textbook and the page opposite to answer the following questions.

#### **Questions**

Q1. Describe how tsunamis occur.

*By large, sudden movements in the Earth's crust, such as those caused by earthquakes and volcanoes.*

---

Q2. Decide which of the following is true or false.

[ T ] A lot of people imagine these waves travel throughout the ocean at great heights.

[ F ] They travel at about 20 km/hr.

[ T ] Because of their great speeds, they rear up to great heights when they do reach the shore.

[ T ] They can travel around the world.

[ F ] They are gravity waves caused by the sudden movement of a large volume of ocean floor.

[ T ] They are recorded on Australia's coastline about once every two years.

[ F ] There is no risk to Australia from Tsunamis.

Q3. Distinguish between a Tsunami and a storm surge.

*A storm surge is caused by a low pressure moving close to the coastline*

---

*A tsunamis is caused by a geological event*

---

Q4. Describe a recent seismic sea wave event in terms of when and where it occurred, the earthquake strength, what happened to the ocean floor and how many people were affected. What could be seen inland that showed the force of the wave? What has been done since?

*When and where*

*250 kilometres south-west of Sumatra. December 26, 2004,*

---

*Earthquake strength*

*9.0 on the Richter scale*

---

*What happened to the ocean floor*

*The ocean floor dropped almost 40 metres and unleashed a seismic wave*

---

*How many people were affected and how many died as a result.*

*Killed over 250 000 people in eight countries across Asia and with effects as far as Somalia in*

---

*East Africa and even off the west coast of Western Australia.*

---

*The force of the wave*

*The wave spread many kilometres inland carrying everything in its path from large trees, ships, buildings and bridges.*

---

*What has been done since.*

*The event was one of the worst natural disasters the world has ever seen and in 2005*

---

*the United Nations planned an Indian Ocean tsunami warning system to attempt to warn nations of the impending disasters.*

---

Q5. Decide how could you tell if a Tsunami was coming and describe what would you do.

*Water goes out far, warning on radio etc - get to higher ground*

---

## Seismic sea waves (tsunamis)

**Tsunamis** (pronounced soon-armies) are produced by large, sudden movements in the Earth's crust, such as those caused by earthquakes and volcanoes (Figure 21.1).

A lot of people imagine these waves travel throughout the ocean at great heights and then crash ashore. In fact they may only be a few centimetres high, but because of their great speeds, they rear up to great heights when they do reach the shore.

Tsunamis are shock waves caused by the sudden movement of a large volume of water. This movement of water is mostly caused by underwater earthquakes or volcanoes.

The waves formed travel long distances (Figure 21.2) and have wavelengths of up to 200 kilometres, wave periods of up to 20 minutes, and speeds of up to 800 kilometres per hour can travel around the world.

On December 26, 2004, an undersea earthquake registering 9.0 on the **Richter scale** struck 250 kilometres south-west of Sumatra. The ocean floor dropped almost 40 metres and unleashed a seismic wave that killed over 250 000 people in eight countries across Asia and with effects as far as Somalia in East Africa and even off the west coast of Western Australia.

The wave spread many kilometres inland carrying everything in its path from large trees, ships, buildings and bridges.

The event was one of the worst natural disasters the world has ever seen and in 2005 the United Nations planned an Indian Ocean tsunami warning system to attempt to warn nations of the impending disasters.

### **Tsunamis in Australia**

A tsunami is recorded on Australia's coastline about once every two years.

Most are very small and classified low risk. However, several large tsunamis have hit Australia's north-west coast (Figure 21.3). This area is classified moderate risk, due to its proximity to Indonesia and other countries where large earthquakes and volcanic eruptions can occur.

Further information:  
Geoscience Australia  
[www.ga.gov.au](http://www.ga.gov.au)

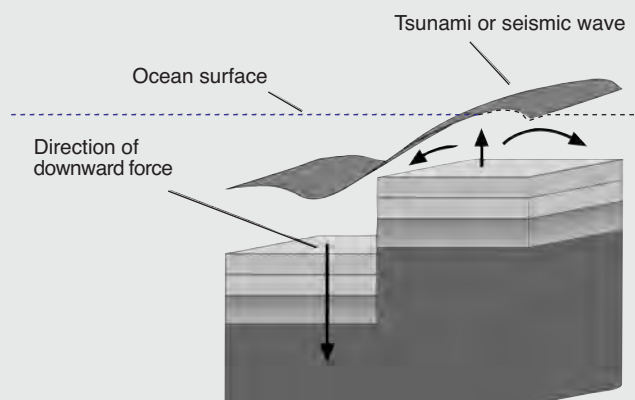


Figure 21.1 Faulting of the ocean floor will generate a seismic wave

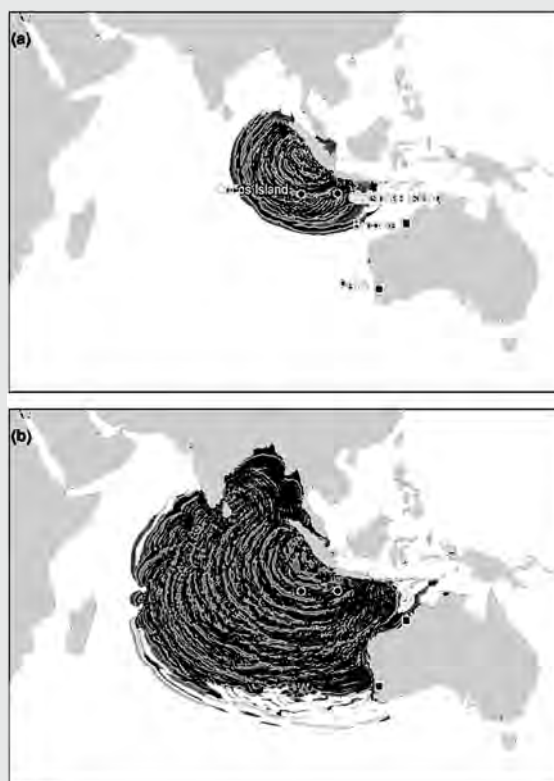


Figure 21.2 Waves can travel long distances  
(Illustration Geoscience Australia)

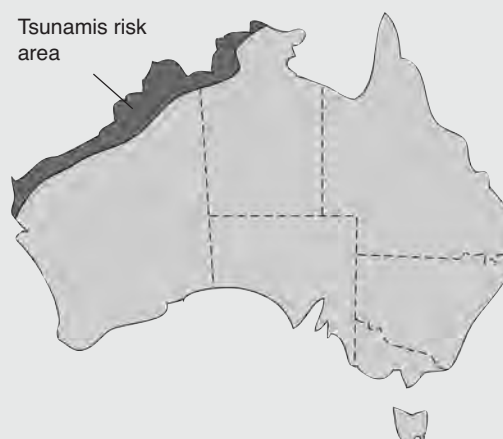


Figure 21.3 Australian tsunamis risk

## Part B: Coastlines

### B1. What are some characteristics of waves?

#### Aims

- To describe parts of a wave and identify how waves form.

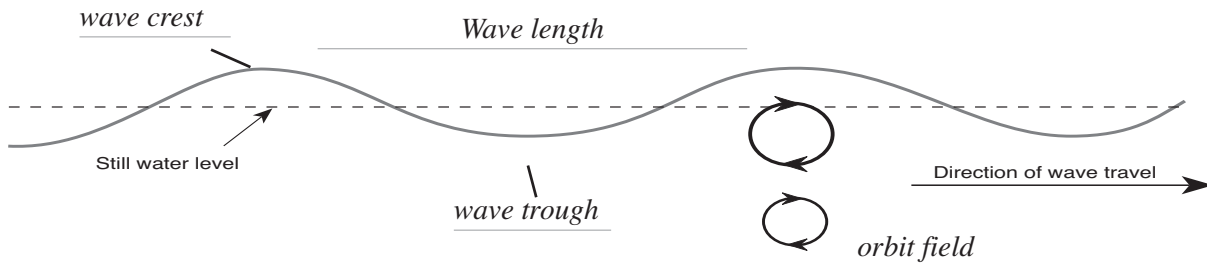
#### What to do

- Read pages 39-40, 42 and 95 of your textbook and answer the questions below.



#### Questions

- Q1. Complete the following diagram to identify the *wave crest*, *wave length*, *wave trough*, *orbit field* or *circular movement of water under a wave*.



- Q2. Distinguish between a spilling wave and a plunging wave.

*A spilling wave breaks at the crest and rolls forward, a plunging wave throws the top out and dumps on the shore.*

- Q3. Define the terms wavelength, wave height and wave period.

*Wavelength is the distance between two successive crests or troughs.*

*Wave height is the vertical distance between the crest and the trough.*

*Wave period is the time for two successive crests or troughs to pass a fixed point.*

- Q4. Define the term fetch.

*The fetch is the area in the ocean over which the wind blows.*

- Q5. Complete the sentence - the bigger the fetch *the bigger the waves or the longer the wavelength*

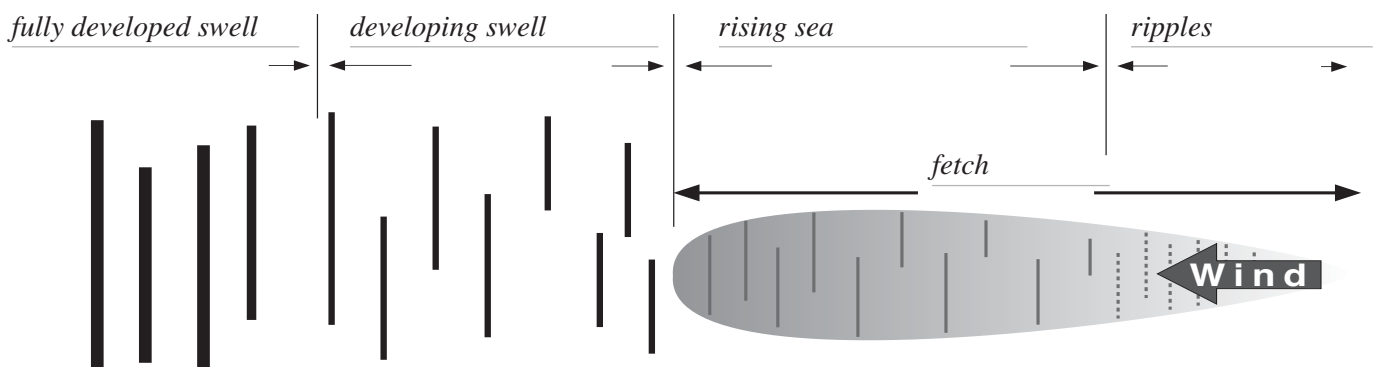
- Q6. What differences exist between waves that break in Hawaii and Western Australia compared to Eastern Australia.

*The length of the fetch is bigger.*

- Q7. List the four things that contribute to the size of waves.

*wind speed, length of time the wind blows, the distance over which the wind travels, the depth of the water.*

- Q8. Complete the following diagram to distinguish between ripples, swell and rising sea. Mark where the fetch is and where a fully developed swell occurs.



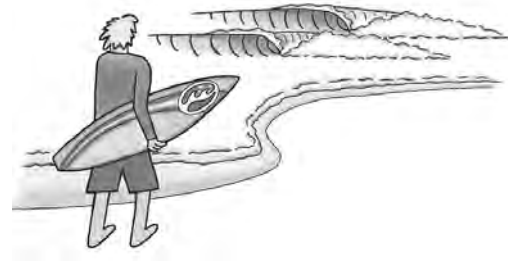
## B2. How fast do waves travel?

### Aims

- To apply some mathematics to waves in the ocean.

### What to do

- Read pages 39-40 of your textbook and answer the questions below.



### Questions

- Q1. Surfers at Bells Beach estimated the waves on that day to be 4 metres in height. They estimated that the time between the waves was 10 seconds or approximately 100 metres between each wave. Calculate the approximate wave speed of these waves. What is this speed in km/hr?

$$V=L/t \quad V = 100m/10s$$

$$V=10m/s \quad 1km = 1000m$$

$$V= 10 \times 60 \times 60 / 1000 = 36km/hr \text{ ANS}$$

- Q2. If a surfer counts 50 waves washing onto the beach in 15 minutes, calculate the wave period (time between waves in seconds) and the wave frequency.

a)  $50 \text{ waves in } 15 \text{ minutes}$

$$\text{Velocity} = L / T$$

$$= 50 / 15 \times 60 = 50 / 900 = 1 / 18$$

$$\text{Period} = 18 \text{ seconds}$$

b)  $\text{Frequency} = \text{No. of waves per time interval}$

$$= 1 / 18 = 0.055 \text{ waves per second (Hz) ANS}$$

- Q3. If a fisher counts 180 waves washing on the beach in 1 hour, calculate the wave's period and frequency.

a)  $= 180 \text{ waves} / 3600 \text{ seconds}$

$$= 1 / 20$$

$$\text{Period} = 20 \text{ seconds}$$

b)  $\text{Frequency} = 1 / 20$

$$= 0.05 \text{ waves per second (Hz) ANS}$$

- Q4. If waves in the sea have a length of 30 metres and a velocity of 28 m/sec, calculate the wave period.

$$L = 30 \text{ m} \quad V = 28 \text{ m / sec} \quad T = ?$$

$$V = L / T$$

$$T = L / V = 30 / 28 = 1.077 \text{ seconds ANS}$$

- Q5. A Tsunami that was caused by an undersea earthquake that occurred off the coast of North America reached Christmas Island in the Pacific Ocean in 6 hours. It was estimated the distance from its point of origin it had travelled 5,000 km (a) Calculate the speed at which the wave moved. (b) Calculate the time it would have reached the Hawaiian Islands, which are located 2,000 km from the epicentre of the earthquake. (c) Calculate how long it would be before the next wave hit the island if the wavelength was 300 km.

$$5000km/ 6 \text{ hrs}$$

$$S = D / T = 5000 / 6 = 833$$

$$\text{The wave was travelling at } 833km/hr \text{ (231 m/sec) ANS (a)}$$

$$D = 2000 \text{ T} = 2.4hrs = 2hrs24min \text{ ANS (b)}$$

$$L = 300 \text{ 000m}$$

$$V = 231m/sec$$

$$T = L / V$$

$$= 300 \text{ 000} / 231 = 1298 \text{ seconds} = 21 \text{ minutes ANS (c)}$$

### B3. How does weather affect waves?

#### Aim

- To describe how weather affects waves.

#### What to do

- Read pages 73-74 of your textbook and the information on the page opposite to answer the questions below.



#### Questions

Q1. Describe how wind forms.

*As the sun heats the oceans of the world, it causes parcels of warm air above the sea to rise. As a result, a partial vacuum above the ocean's surface is created and nearby, cooler air moves into this space.*

*This movement of air is called wind.*

Q2. Define the term trade wind.

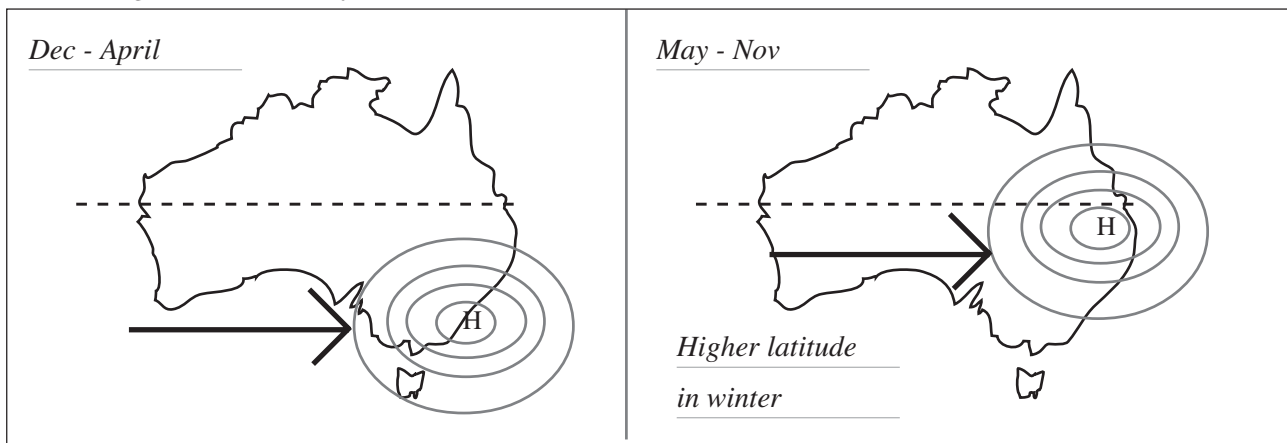
*Places where air sinks to form areas of high pressure.*

*The spinning earth moves these pressure cells in patterns called trade winds.*

Q3. Distinguish between the summer and winter movement of high pressure cells in Australia.

*During January and March high pressure systems tend to move at lower latitudes over Australia creating different wind patterns and sea conditions compared to September to December*

Draw a diagram to illustrate your answer.



Q4. Explain how this can affect surf conditions at the following famous surf breaks - Bells Beach (Vic), Margaret River (WA), Cronolla Beach (NSW) and Snapper Rocks (Qld).

*Dec - April waves at Margaret River can be big due to fetch from Antarctic and cyclones in Qld can cause big surf. May - Nov low pressures generate big surf in NSW from Tasman Sea, Big winter waves at Bells.*

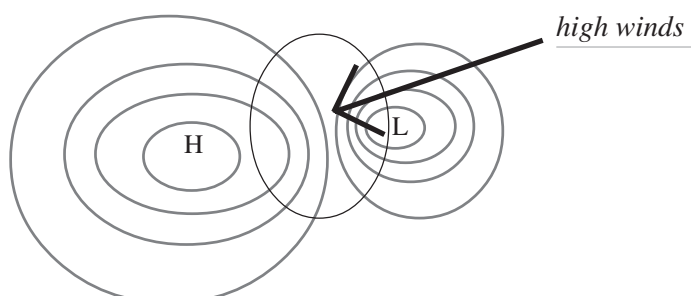
Q5. Describe what effect low pressure systems have on pressure gradients.

*Low pressure systems can also increase wind speed and direction as they squeeze high pressure.*

*system isobars close together. Winds increase as the isobars squeeze together.*

Q6. Describe how pressure gradients affect swell size and direction. Illustrate your answer in the space opposite.

*They squeeze the isobars together making high winds and bigger waves.*





# Waves and weather

## Wind

**Waves** are living energy created by the sun.

As the sun heats the oceans of the world, it causes parcels of air above the sea to rise. As a result, a partial vacuum above the ocean's surface is created and nearby, cooler air moves into this space. This movement of air is called **wind**. As the wind moves over the surface of the sea, it causes the surface to wrinkle and drags the water molecules into a **ripple**. The more the wind blows, the bigger the ripples until finally a wave is formed (Figure 25.1).

## Trade winds and surf

The sun's rays heat the earth unequally. More earth is heated at the equator than at the poles. On a large scale, air heated at the equator (the lower latitudes), rises faster and creates an area of low pressure below it. Because of this rising air, cells of low pressure form around the equator (Figure 25.1).

In the mid latitudes, the places where air sinks form areas of high pressure. The spinning earth moves these pressure cells in patterns called **trade winds**. As the high pressure moves from left to right the direction in which the wind blows will vary.

During January and March high pressure systems tend to move at higher latitudes over Australia creating different wind patterns and sea conditions compared to September to December (See Figure 25.2).

For those who surf, this makes a big difference to the type of surf experienced. From Bells Beach in Victoria, Margaret River in Western Australia or to Noosa Heads in Queensland, the surf can vary on the coast.

## Pressure systems

Low pressure systems can also increase wind speed and direction as they squeeze high pressure systems **isobars** close together. Winds increase as the isobars squeeze together as shown by Figure 25.3 below. Wind speeds of 35 - 45 knots over a day can increase the wave height from 1 to 3 - 5 metres. However once the low moves out to sea and the wind decreases back to 5 - 10 knots, the wave height soon drops back to a metre of swell.

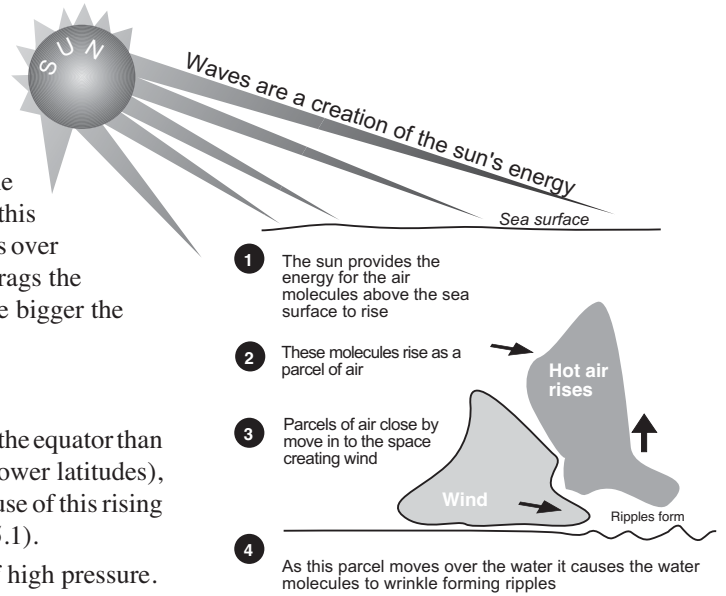


Figure 25.1 How wind forms

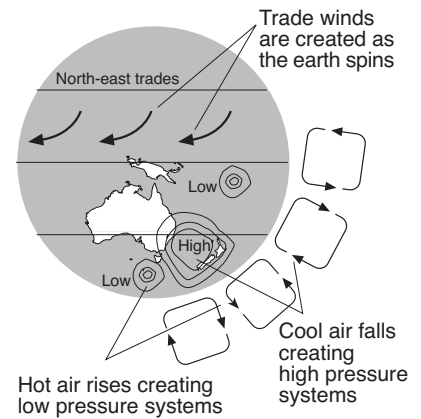


Figure 25.2 How pressure cells form

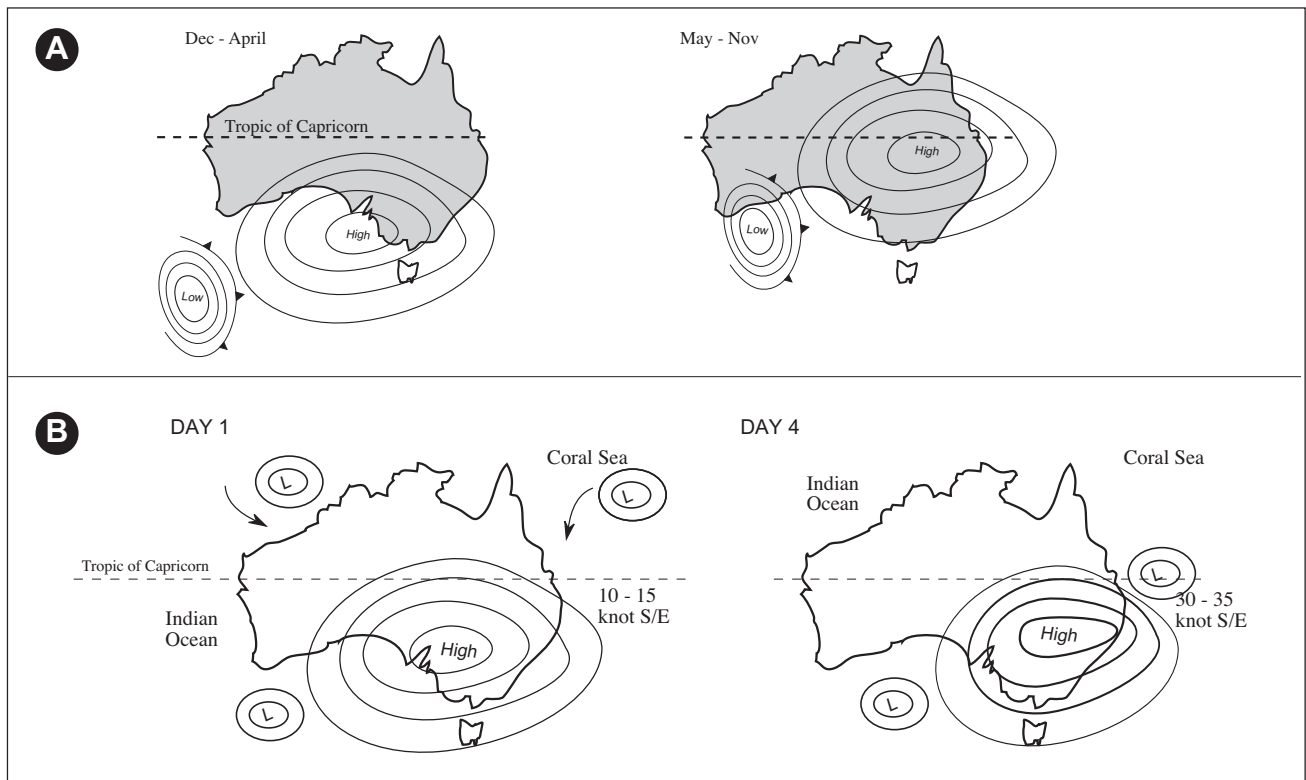


Figure 25.3 Effects of high and low pressure systems summer and winter

## B4. What happens when currents approach a shore?

### Aim

- To explain what happens when currents approach the shoreline.

### What to do

- Read pages 69 - 71 of your textbook, and answer the questions below.

### Questions

- Q1. Explain the difference between tidal, overflow, estuarine and longshore currents. Complete the diagrams to the right to illustrate your answer.

#### Tidal

Tidal currents form when there is a large rise and fall in narrow channels or around headlands.

#### Overflow

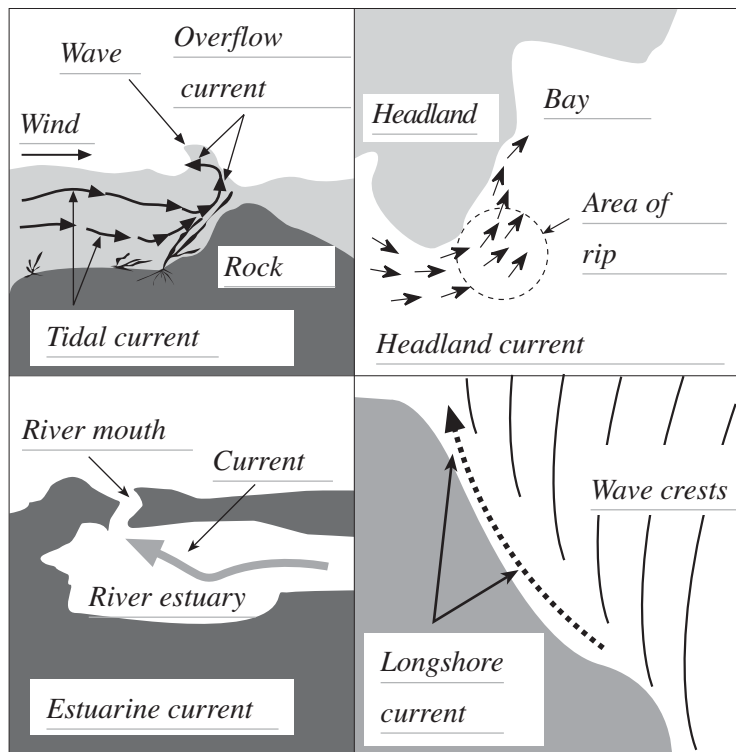
Overflow currents occur when water runs over submerged reefs or bommies in a river mouth

#### Estuarine

Estuarine currents occur in estuaries as the tides goes in and out

#### Longshore

Longshore currents occur when waves approach the beach at an angle



- Q2. Explain how satellites helped oceanographers research ocean currents.

It allowed the overall picture of ocean currents not just fragments to be seen.

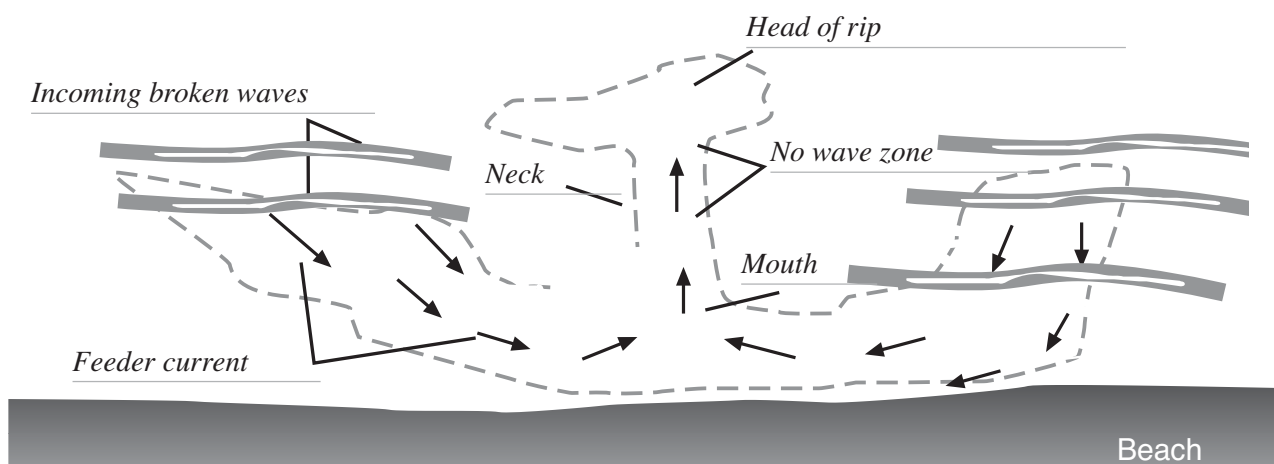
- Q3. Distinguish between four types of rip current and complete the diagram below to illustrate your answer.

Permanent, where the current remains in the same place for months, even years;

Fixed, where a gutter or depression in beach sand keeps a rip in place for months;

Flash rips, where a depression suddenly occurs in a beach profile; and

Travelling, where a rip moves up the coast



## B5. How is sand made and transported in a coastal system?

### Aim

- To distinguish between carbonate and non-carbonate sand.

### What to do

- Read page 89 - 93 of your textbook and answer the questions below.

### Questions

Q1. Distinguish between carbonate and non-carbonate sands and how they are made.

*Carbonate sands come from the remains of dead animals that had calcium carbonate in them.*

*Non-carbonate sands are made of minerals eroded as far back as pre-glacial times.*

Q2. Study Figure 89.2 in your textbook and match the numbers with the following sand type description, giving a reason for your answer.

No/s	Description of sand grain	Reason
2,6	washed down rivers and into the sea	<i>rounded and made of tough minerals like quartz &amp; silica</i>
3	cut by a glacier	<i>grain with very sharp edge, much force needed</i>
2,6	broken down to form clay and silt	<i>can see sediment covering the surface, borers visible</i>

Q3. Describe how sand is transported to a beach system.

*By rivers, currents and waves.*

Q4. Define the term longshore drift.

*The slow movement of sand along a beach.*

Q5. Describe any 5 things that are happening in the diagram opposite as identified by your textbook.

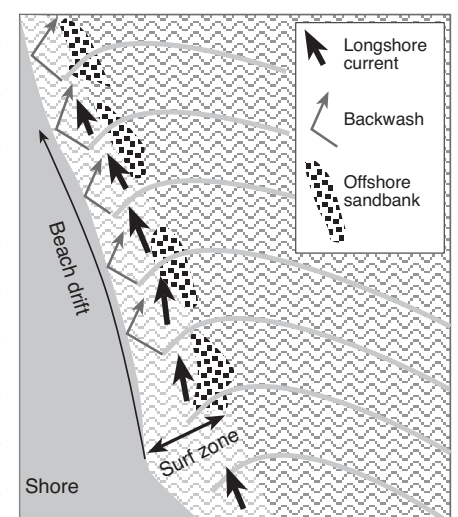
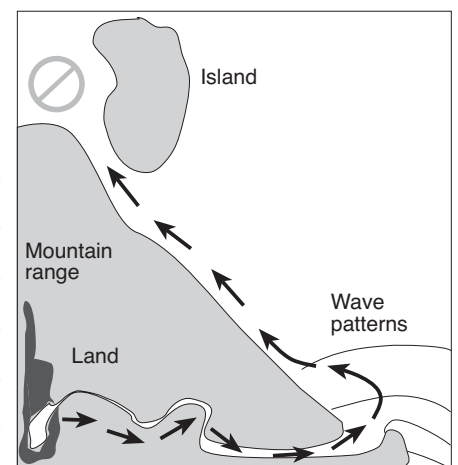
*1. Sand is made in the mountain range and transported down rivers*

*2. Tough sand grains end up at the river mouth where they are picked up by waves and transported and deposited further up the coast by the longshore drift*

*3. As waves approach the beach they break and carry the sand up the beach.*

*4. The wave then recedes and drags the sand back into the ocean.*

*5. As the wave approaches the beach at an angle, the sand grains move in a zigzag pattern along the beach.*



Q6. Define the term sand budget and give an example.

*The sand budget is the net movement of sand into and out of the sand system expressed as income and expense*

*Income - Rivers, streams, beach nourishment, cliff erosion*

*Expense - damming of rivers, mining, offshore wind, deposition into bays*

## B6. Why do tides change over the month?

### Aim

- To plot a graph to show the differences in tides over the month.

### What to do

- Study the tide tables for July in the illustration to the right.
- Using a computer spreadsheet, plot a graph of days v's tide heights over 31 days on the next page and answer the questions below.

### Questions

- Q1. Distinguish between spring and neap tides on your graph and list the approximate dates for each.

*Spring tides occur on the full and new moons - 1st, 16th and 30th July*

*Neap tides on the first and last quarter - 7th and 24th July*

- Q2. Distinguish between the day, dates, times and high tide heights on these dates.

*Spring tide heights*

*Neap tide heights*

*Monday 1st July 2315 - 6.27 metres*

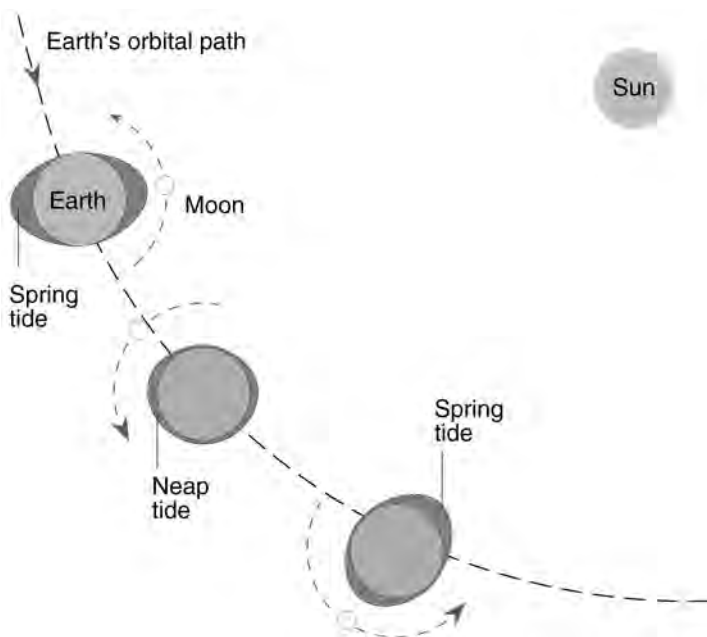
*Sunday 7th July 1122 - 4.51 metres*

*Tuesday 16th July, 2331 - 5.39 metres*

*Wed 24 July 0432 - 4.08 metres*

*Tuesday 30th July, 2346 - 6.26 metres*

- Q3. Complete the Earth's orbital path illustration to show the difference between spring and neap tides by using the symbols on the box below.



JULY			
Time	m	Time	m
1 0505	0.45	16 0530	1.03
MO 1050	4.96	TU 1116	4.36
○ 2315	6.27	● 2331	5.39
2 0555	0.36	17 0559	1.07
MO 1140	4.96	TU 1144	4.32
TU 1750	0.15	WE 1745	0.94
		2359	5.28
3 0002	6.23	18 0625	1.13
MO 0643	0.36	TH 1212	4.29
○ 1839	0.32	TH 1814	1.07
4 0050	6.03	19 0027	5.14
TH 0731	0.46	FR 0653	1.20
TH 1322	4.79	FR 1243	4.22
1929	0.60	1845	1.25
5 0140	5.71	20 0056	4.94
FR 0821	0.63	SA 0723	1.30
FR 1417	4.65	SA 1317	4.13
2021	0.95	1919	1.48
6 0233	5.31	21 0130	4.70
SA 0915	0.82	SU 0800	1.40
SA 1518	4.54	SU 1400	4.04
2122	1.31	2001	1.73
7 0333	4.90	22 0212	4.44
SU 1015	0.97	MO 0845	1.50
SU 1628	4.51	MO 1457	3.99
2236	1.58	2100	1.95
8 0445	4.57	23 0310	4.20
MO 1122	1.03	TU 0949	1.52
MO 1744	4.62	TU 1615	4.07
●		2227	2.04
9 0002	1.64	24 0432	4.08
MO 0601	4.40	TH 1106	1.40
TU 1230	0.99	WE 1736	4.35
1855	4.85	● 2359	1.85
10 0120	1.49	25 0553	4.15
WE 0713	4.37	TH 1218	1.14
WE 1331	0.89	TH 1845	4.78
1954	5.11		
11 0222	1.28	26 0113	1.49
TH 0812	4.40	FR 0701	4.33
TH 1424	0.80	FR 1320	0.82
2043	5.32	1945	5.24
12 0312	1.12	27 0216	1.10
FR 0900	4.43	SA 0802	4.55
FR 1508	0.75	SA 1417	0.53
2124	5.45	2039	5.65
13 0353	1.02	28 0313	0.75
SA 0941	4.44	SU 0858	4.75
SA 1545	0.74	SU 1511	0.28
2200	5.51	2129	5.98
14 0430	0.99	29 0404	0.47
SU 1016	4.43	MO 0949	4.92
SU 1619	0.76	MO 1602	0.10
2233	5.51	2215	6.21
15 0501	1.00	30 0453	0.25
MO 1048	4.39	TU 1038	5.07
MO 1649	0.80	TU 1651	-0.01
2303	5.47	○ 2301	6.32
		31 0539	0.13
		WE 1126	5.16
		WE 1738	-0.01
		2346	6.26

#### Spring tides

○ Full Moon ● New Moon

#### Neap tides

◐ 1st Quarter ◑ 3rd Quarter

Copyright Flinders University

#### Symbols



Sun



Neap tide



Moon



Spring tide

Graph of Tide heights v's days in July

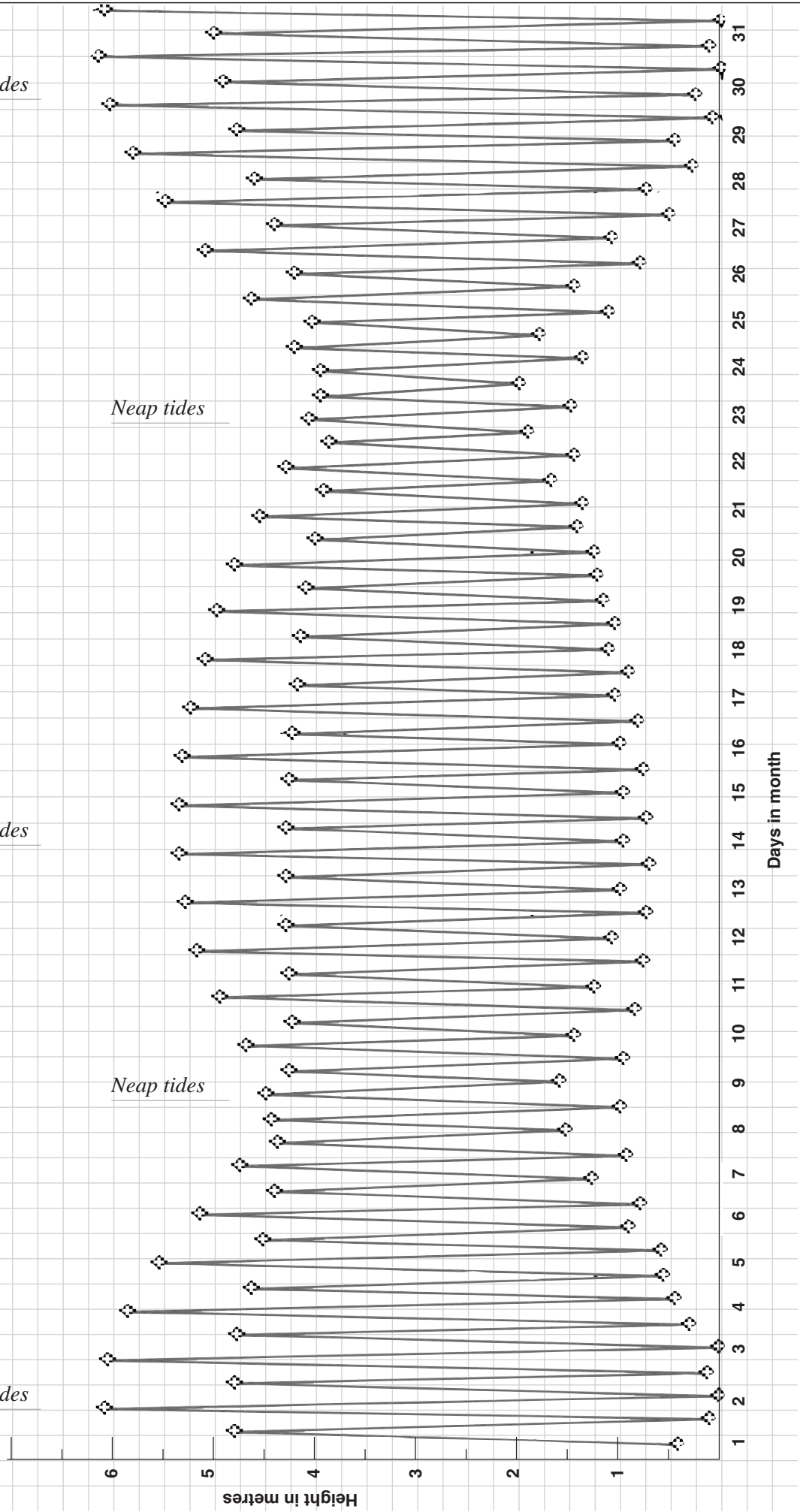
*Spring tides*

*Neap tides*

*Spring tides*

*Neap tides*

*Spring tides*



## B7. What happens to waves as they approach a beach?

### Aim

- To describe what happens to waves as they approach a beach.

### What to do

- Read pages 41 and 75 of your textbook. Then read the page opposite and answer the questions below.

### Questions

Q1. Define the term shoaling wave.

*Shoaling waves are those that approach the shore and change shape  
or shoaling means wave length and speed decrease, troughs rise and crests fall  
above mean sea level until the wave breaks.*

Q2. Explain the term surf in terms of energy and wave shape.

*As a wave approaches the shore it loses its shape, topples and releases energy in the form of surf*

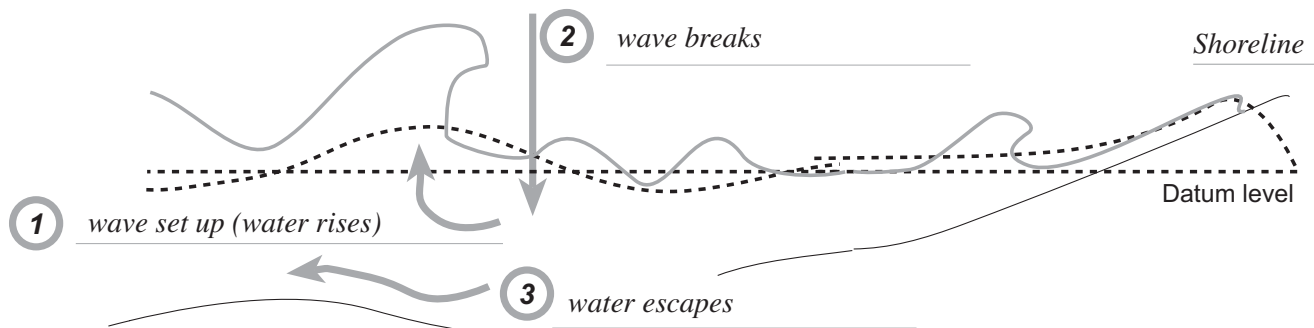
Q3. Define the term wave set-up.

*Wave set-up is the rise in water level above the datum level as a shoaling wave approaches the shore.*

Q4. Describe what happens under a wave as it breaks.

*When the wave breaks, the crest tumbles and falls into the trough at the base of the wave  
The water is then pushed down and escapes in the reverse direction under the wave.*

Q5. Complete 1 - 3 in the diagram below to illustrate your answer.



Q6. Complete the sentence.

Shoaling means wave length and speed decrease,  
troughs rise and crests fall above mean sea level until  
the wave breaks .

Q7. Explain how a surfer duck dives using the wave set up escape region.

*If the surfer can position the surfboard into this set up escape region, the surfer pushes the board down  
deep enough to catch the set-up escape mechanism to pop out the other side.*

## Shoaling waves

Waves that approach the shore and change shape are called shoaling waves (Figure 31.1).

- These are characterised by the fact that their trough rises as they approach the shore and they lose their energy to the sea floor over which they move.
- When a wave approaches the shore the water above the datum point rises.
- This rise in a shoaling wave situation is called the wave set-up.
- The water escapes under the wave over the offshore sand bars as indicated in the Figure below.

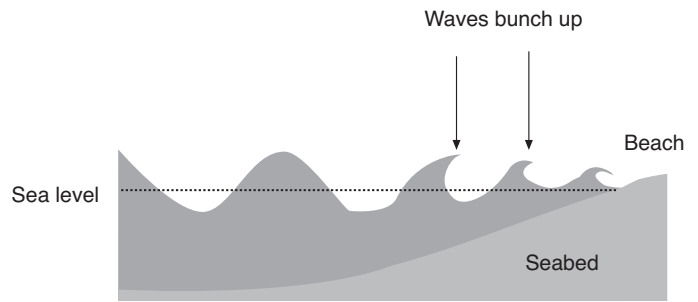


Figure 31.1 Waves approaching a beach

A common technique surfers use to get under waves these days is called duck diving (Figure 31.2).

If the surfer can position the surfboard into this set up escape region, the surfer pushes the board down deep enough to catch the set-up escape mechanism to pop out the other side.

Each wave break reforms and breaks again about half its previous height (Figure 31.3).

- The height of the wave above this wave set-up decreases as the waves approach the beach as shown by  $H_1$ ,  $H_2$  and  $H_3$ .
- Wave set up occurs on the beach by wind and wave action and is the final point at which all the energy given to the wave by the wind is lost.

Shoaling means wave length and speed decrease, troughs rise and crests fall above mean sea level until the wave breaks.

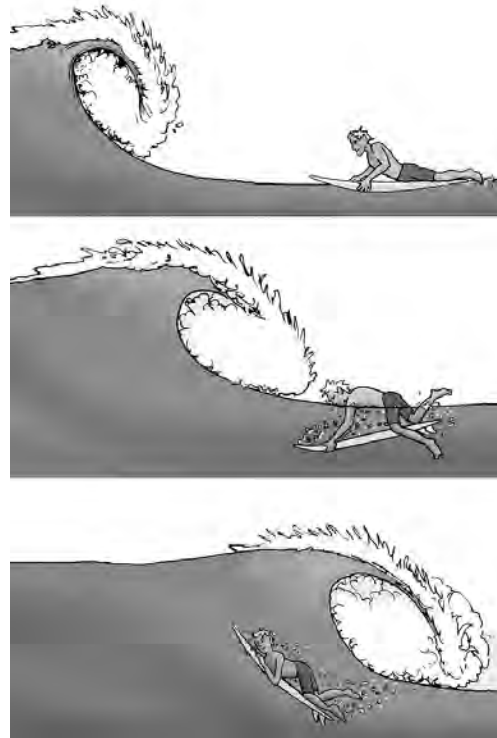


Figure 31.2 Duck diving

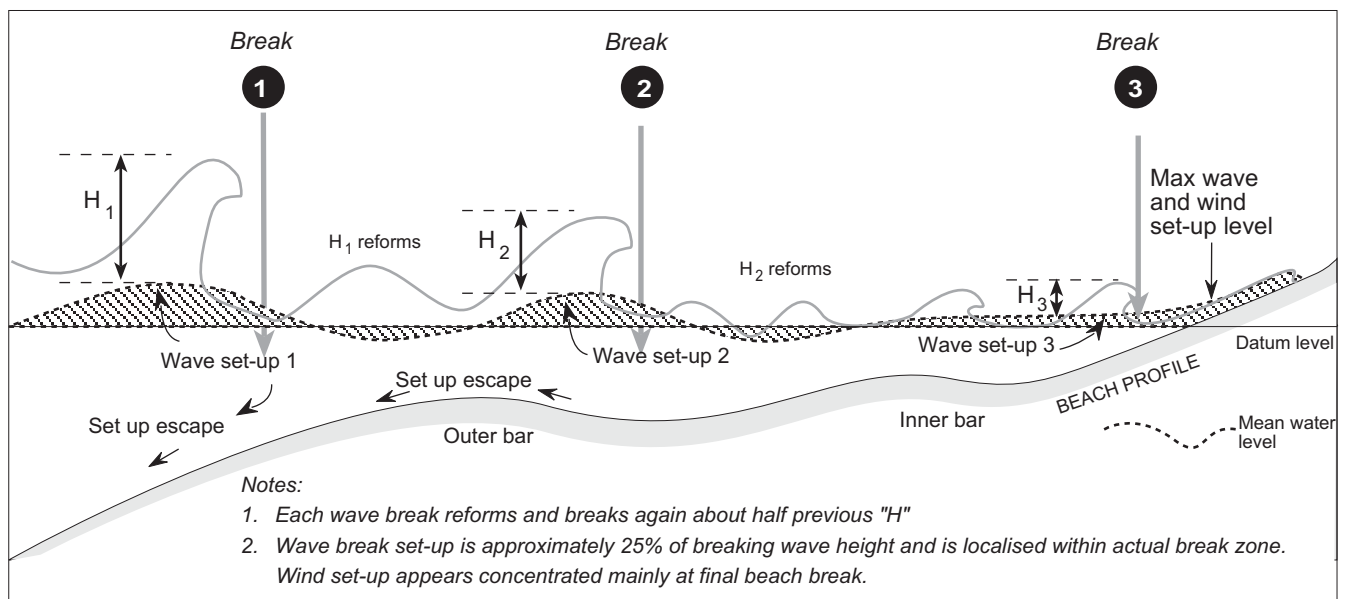


Figure 31.3 Characteristics of shoaling waves. After Smith, Sam. 1990.

## B8. How does sand get onto a beach?

### Aim

- To explain how sand gets onto a beach.

### What to do

- Read page 95 - 96 of your textbook and answer the questions below.

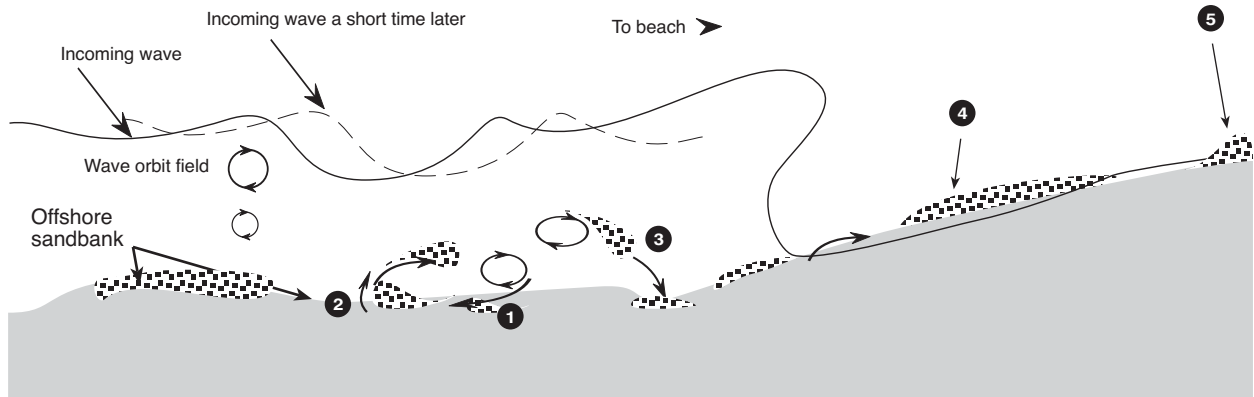
### Questions

Q1. Define the term wave bore.

*The wave bore is the broken part of the wave in the swash zone that transports the sand up the beach.*

Q2. Define the term microridge.

*The pile of sand that is left behind on a beach as the wave recedes.*



Q3. Describe what is happening in the diagram above by writing a sentence after each number.

1. *Orbit field pulls sand back.*

2. *Incoming wave orbit field catches sand and pushes it forward.*

3. *Waves momentum carries sand past its original position and drops it closer to shore.*

4. *Sand carried up beach in broken waves.*

5. *Microridge forms where wave stops.*

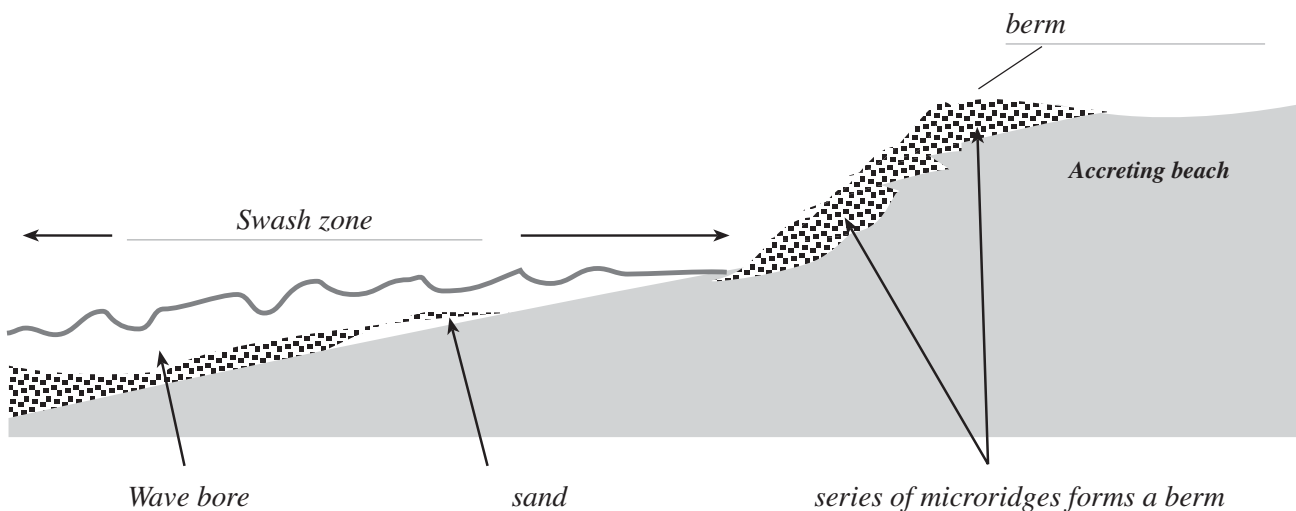
Q4. Define the term beach berm.

*A series of microridges that forms during calm weather by constructive waves.*

Q5. Define the term accreting beach.

*An accreting beach is one where sand is moving onshore to form microridges.*

Q6. Complete the diagram below to illustrate your answers to Questions 4 and 5 above.





**B9. What are sand dunes and how are they made?**

**\*Note:**

If you are using the 2003 or 2005 editions of *Marine Science*, you will have to google an answer for Q5.

**Aim**

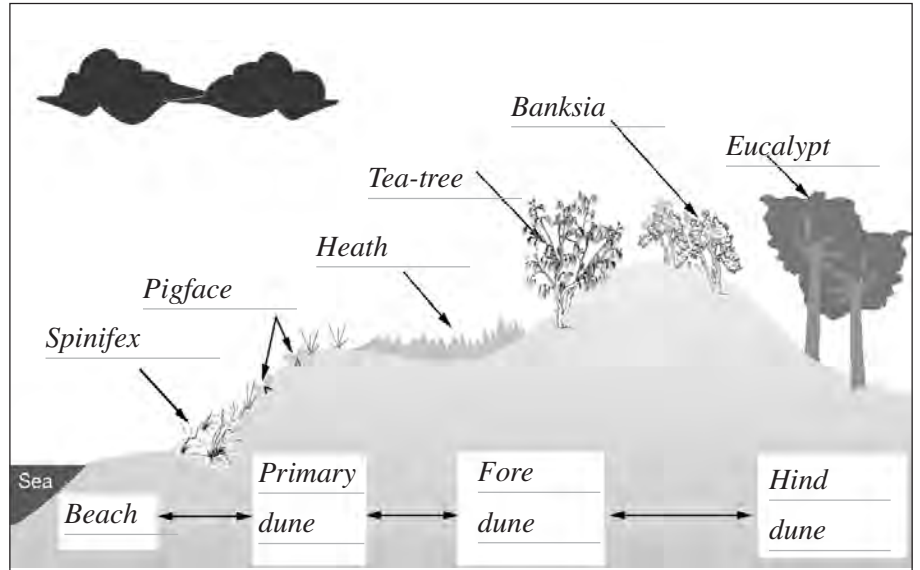
- To describe how sand dunes are formed.

**What to do**

- Read\* pages 92, 94 and 95 of your textbook and answer the questions below.

**Questions**

- Q1. Use Figure 96.4 in your textbook to label the figure opposite.
- Q2. Name the type of waves that deposit sand on the beach.  
Constructive waves
- Q3. Locate the missing words in the sentences below from your textbook.



Where beach sand is moving onshore an accreting beach is said to occur.

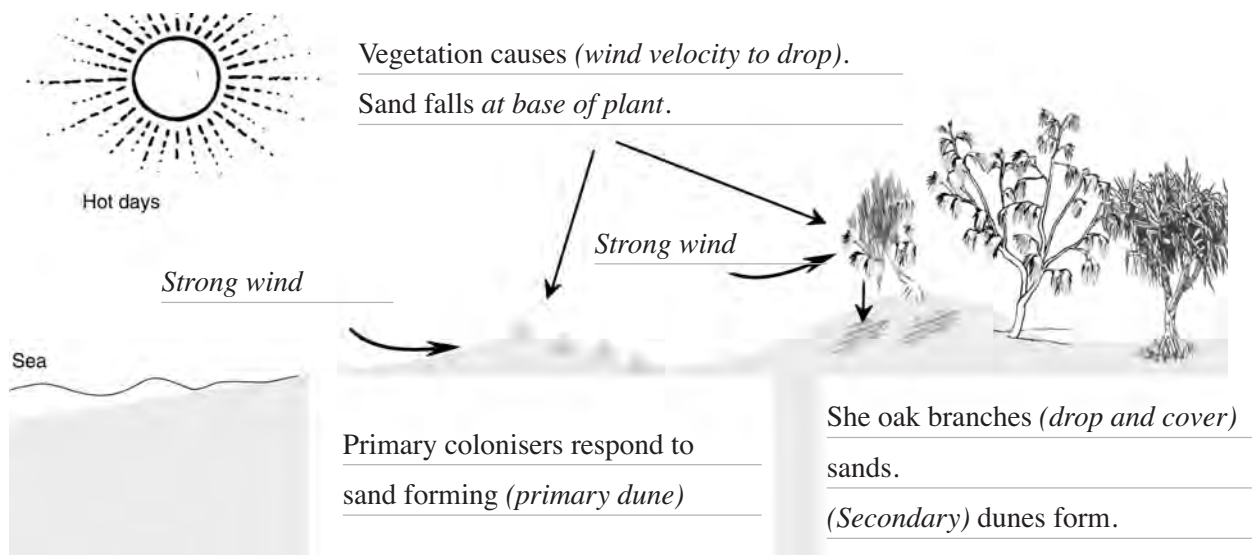
On hot, sunny, windy onshore days the sand in the berm is quickly blown up the beach.

Spindle-like plants called spinifex slow the wind carrying the sand which deposits at the base of the dune plant.

This forms the structure called a primary dune .

If the wind is strong enough, the sand continues over the primary dune where it accumulates under the branches of vegetation a second set of dunes called a secondary dune.

- Q4. Summarise your understanding of sand dune formation by completing the figure below.



- Q5. Explain the terms ecological succession and climax community used to describe a dune system.  
Ecological succession is the change in the species from the primary dune to the hind dune in the figure above  
The climax community is the biological community of plants and animals which, through the process of ecological succession has reached a steady state. This equilibrium occurs because the climax community is composed of species best adapted to average conditions in the dunes.

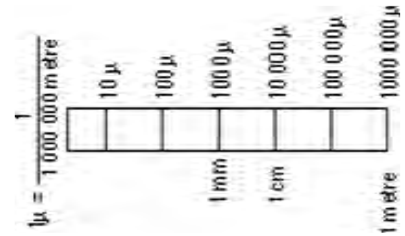
## B10. Can we classify sand grain sizes found on a beach?

### Aim

- To describe and classify different sand grain sizes found on a beach.

### What to do

- Read page 89 - 91 of your textbook and answer the following questions.



### Questions - Part A

- Q1. If the distance across the photo in Figure 89.2 on page 89 of your textbook measures 1.2mm or 1200μ metres, estimate the size of grain No 3.

*Sand grain 3 is approximately 400 μm (0.4mm).*

- Q2. Describe the shapes of grains 2 and 3. What are the obvious differences in shape?

*Sand grain 2 is rounded. Grain 3 has sharp edges.*

- Q3. Describe how the breakdown of grain 1 occurred.

*Grain 1 is from the continental shelf, where it was eroded by extreme hot /cold during last ice age.*

- Q4. Explain how extremes of hot and cold erode rocks.

*Heat causes expansion, which can cause pressure to build up.*

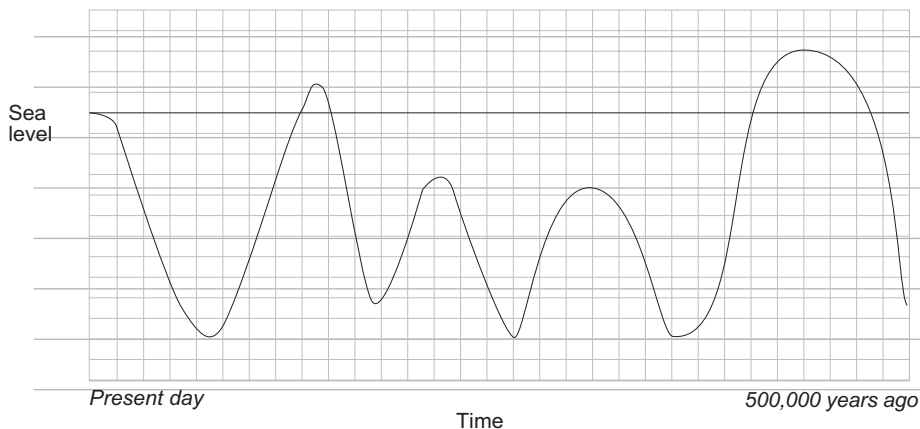
*Hot things can shatter if they are cooled quickly.*

*Water that freezes in tiny cracks expands when it freezes, causing cracks to grow and rocks to split.*

- Q5. Explain how the textbook describes the formation of Fraser and Moreton Islands in Queensland.

*Fraser and Moreton Islands were formed by sand accumulating from 120 km/hr northerly winds, during the last ice age.*

- Q6. Sketch a graph showing how the sea levels may have changed over the last 500,000 years. Explain your reasoning.



*Any acceptable answer*

*Evidence of inland seas and ancient reefs*

*Coral re-growth*

- Q7. Describe how and when sand grain 3 was formed. If this grain was placed on a beach for a long period of time explain how its shape might change.

*Sand grain 3 was formed by a glacier smashing rocks, when Australia was separating from Antarctica.*

*If it was on a beach the abrasive action of the sand and waves would round off the sharp edges.*

- Q8. Propose an explanation for the strength and direction of the wind during the Ice Ages.

*Strong winds that occur near to the poles occurred further north.*

*Cold air over the ice would cause high pressure areas and strong winds.*

**Questions - Part B**

Questions 9 - 12 refer to Figure 91.1 in your textbook.

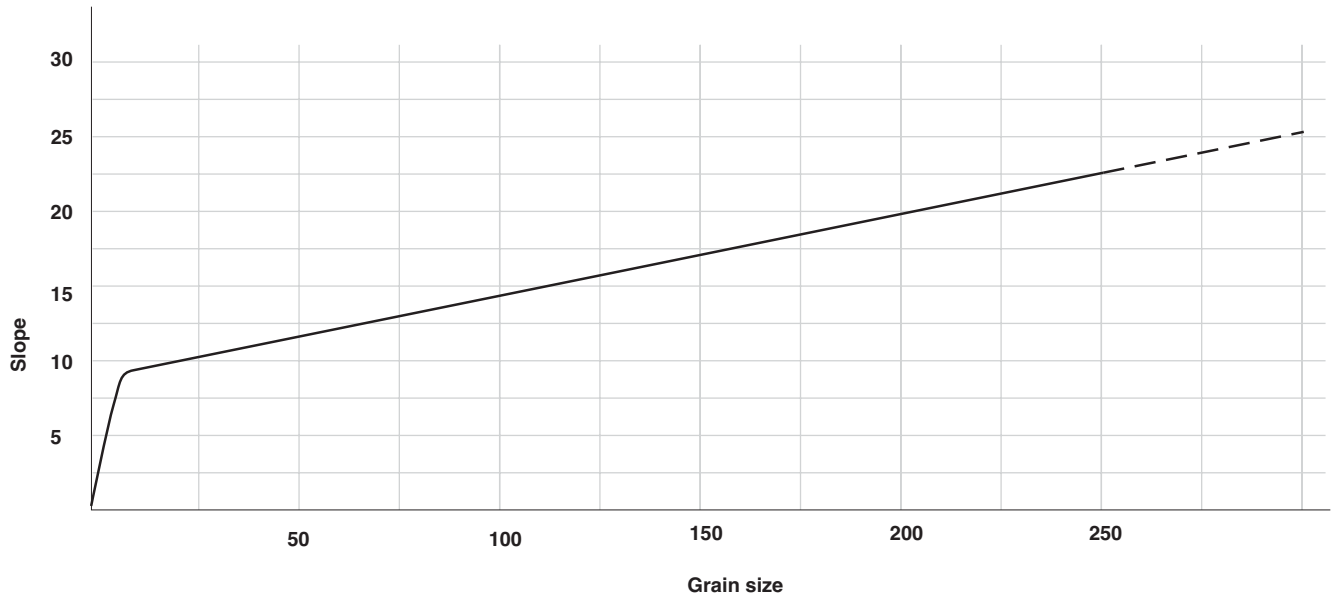
Q9. Recall what gravel beaches consist of and the average slope angle of this type of beach.

*Gravel beaches consist of cobbles, pebbles and granules,  
and have an average slope of 10-25°.*

Q10. Recall the size range of sand.

*Sand ranges in size from medium (0.25mm) to very coarse (2mm).*

Q11. Using Figure 91.1, organise the data on grain diameter and average slope of the beach into a graph.



Q12. From the graph predict the slope of a beach if the diameter of the particles on the beach averages 100mm.

*A beach with 100 mm particles would have a slope between 10-25°.*

Q13. Explain the interrelationship between sand type and beach shape.

*The bigger the particles the steeper the beach.*

Q14. A student visiting a beach found by doing a sand analysis that the average size of grains was 1 mm yet the beach slope was measured to be 15 degrees. Propose an explanation for this result.

*The student may only have sampled finer sand particles that had recently  
blown in, or may have been visiting an accreting beach.*

Q15. Study the sand grains A - C in the photos on page 91 of your textbook and use the table in Figure 91.1 to classify them.

*A- Sand*

*B- Sand or Gravel*

*C- Mud.*

## B11. Can we determine the percentage composition of sand on a beach?

Based on an original exercise by Bob Moffatt

### Aim

- To collect and analyse different sand grain sizes on a beach.

### What to do

- Read pages 100 - 103 of your textbook and complete the experiment on percent sand composition. Write up your experiment on the next page and then answer the questions below.

Station	Hht (m) + or -	Absorption* time (secs)	% sand grains		
			large	med	small
1					
2					
3					
4					
5					
6					
7					
8					

Station	Hht (m) + or -	Absorption* time (secs)	% sand grains		
			large	med	small
9					
10					
11					
12					
13					
14					
15					
Swash zone					

### Questions

Q1. Complete the data table above from the James Beach data on page 103 of your textbook.

Q2. Describe the difference between the percent composition of sands on the beach.

*The big sand grains are at the bottom and the small sand grains are at the top.*

Q3. Propose reasons for your answer.

*Wave action is greatest at the bottom of the beach in the swash zone. Only the larger grains can stay here.*

*The smaller grains are carried up into the microridges where they dry in the sun.*

*If the wind blows onshore the grains are blown up the beach and get trapped in the beach vegetation.*

Q4. Decide if the beach is eroding or accreting. Give reasons for your answer.

*If accreting no erosion scarp, if eroding you would see an erosion scarp.*

Q5. Explain where the sand for the beach has come from.

*Waves bring it on shore in the wave bore, dry in the microridge and blow up the beach into the dune vegetation.*

Q6. Compare the absorption times for the different stations on the beach.

*The beach is dryer at the top near the dunes*

Q7. Write a hypothesis for the experiment in terms of wave action and swash zone.

*If the big grains are kept by the waves at the bottom of the beach then there will be a higher percentage of big sand grains in the swash zone compared to small sand grains*

Q8. Propose a proof that vegetation traps sand grains.

*The height of the sand dune will be larger around vegetation compared with open beach*

Q9. Explain how to measure the sand absorption rate on a beach.

*At each station insert a tube into the sand and using a graduated cylinder pour a measured amount of water down the tube.*

*Measure the time taken for the water to be absorbed by the beach.*





**Experiment title**

*Students own data, but write up should follow scientific standard procedures*

**Aim**

**Method**

**Results**

*Students own data*

A large grid of graph paper for recording data, consisting of 20 columns and 30 rows of small squares.

**Conclusion**

### B13. How do the dune cycles occur?

An original exercise by Bob Moffatt

#### Aim

To describe how sand dunes protect themselves from being washed away.

#### What to do

Read pages 97-98 of your textbook and answer the questions below.

#### Questions

Q1. Describe how sand is moved from a beach in a high energy event.

*Storm waves caused by high winds attack the sand dune causing an erosion scarp.*

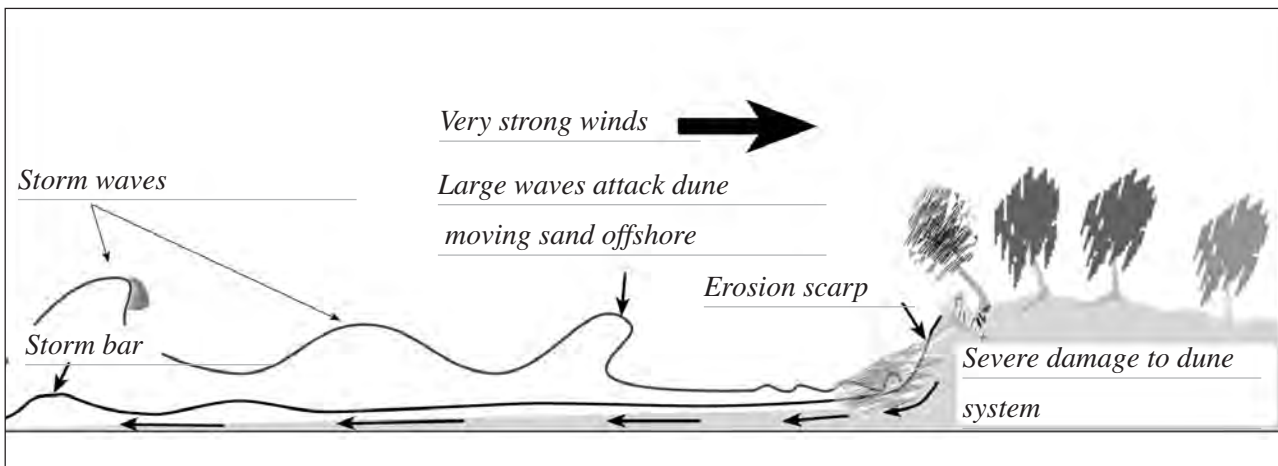
*The sand moves offshore to form a storm bar.*

Q2. Name two things that protect dune systems from being washed away. Explain your answer.

*Vegetation such as she oaks and spinifex grass bind the dunes together.*

*The storm bar offshore absorbs large amounts of wave energy before it strikes the eroded sand dunes.*

Q3. Complete the illustration below to explain your answers to Questions 1 and 2.



Q4. Complete the following sentences to describe the role of beach vegetation in the dune system.

When dunes erode, the roots of the plants and shrubs are left dangling on the erosion scarp.

The dangling roots are called the fretting.

These roots will trap sand as it is blown up the beach from the dry microridges.

Again it may take up to 18 months for the original profile to be re-established and it is important that the dune vegetation is protected from damage.

Q5. Recall another name for storm waves and explain how they can occur.

*Destructive waves. These can occur when low pressure systems interact with high pressure systems to form a tight pressure gradient. Very strong winds occur whipping up big seas.*

Q6. Explain how longshore drift adds to the sand budget.

*Longshore drift brings the sand into the beach system. The waves then wash the sand up onto the beach.*



## B14. What happens when the dune cycle is broken?

An original exercise by Bob Moffatt

### Aim

To describe the consequences of human interference with our coastal zone.

### What to do

Read pages 111-119 of your textbook and answer the questions below.

### Questions

Q1. Describe how humans have altered our coastal zone in the past 70 years using the Gold Coast as an example.

*Dune vegetation has been cut down and development of houses and high rises.*

*Dams have been built reducing the flow of sand into the longshore drift.*

*Groynes and training walls have been constructed.*

Q2. Describe how this has affected the sand budget. Cite some figures in cubic metres to illustrate your answer.

*The volume of sand in the longshore drift has been reduced by up to 500,000 cubic metres per year.*

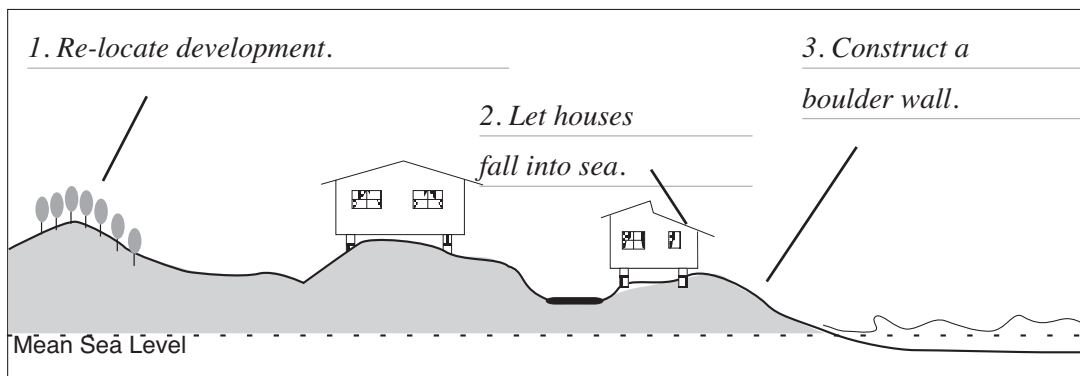
Q3. Describe three problems sand erosion has caused.

*Massive amounts of sand erosion caused houses to fall into the sea.*

*Beach owners have had to build boulder walls to protect their property.*

*Surfers have become angered over loss of beach amenities and surf breaks (eg Kirra).*

Q4. Complete the diagram below to illustrate three possible solutions to beach erosion.



Q5. Describe a groyne and state its function.

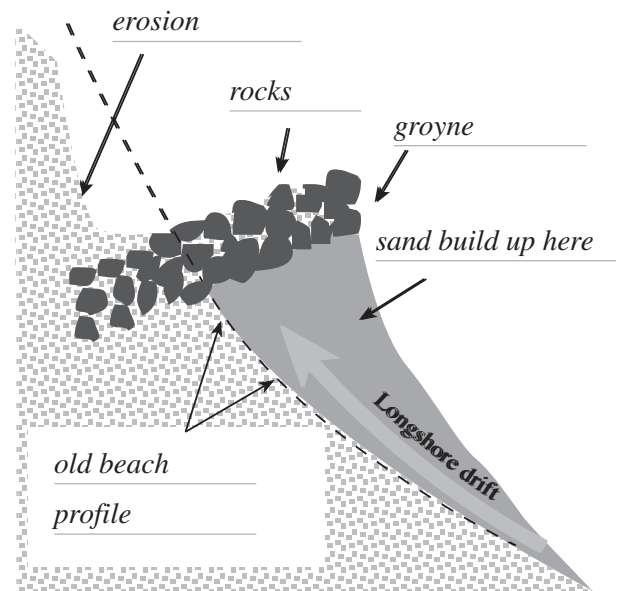
*A groyne is a boulder wall that has been built at right angles to the beach to trap sand.*

Q6. Complete the diagram opposite to show what a groyne does to sand in the longshore drift.

Q7. Explain why training walls have been built and what problems they cause to the longshore drift.

*Training walls are built at the mouths of rivers to make the entrance navigable.*

*They trap sand for long periods of time, reducing the sand budget for the coastline on the other side.*



## B15. When is beach nourishment a solution to coastal management?

An original exercise by Bob Moffatt

### Aim

To describe how beach nourishment is used to combat beach erosion.

### What to do

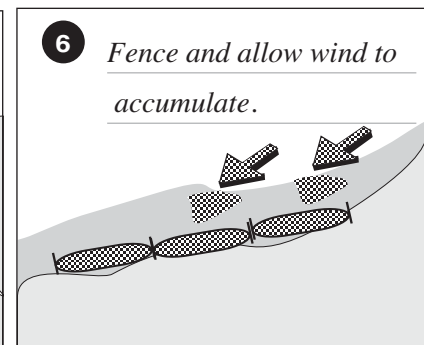
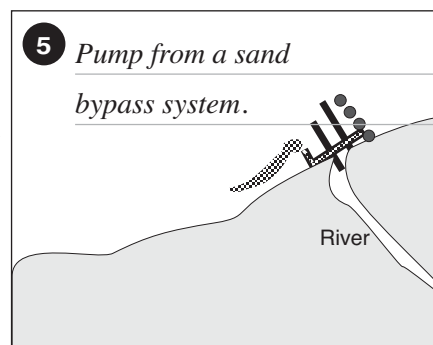
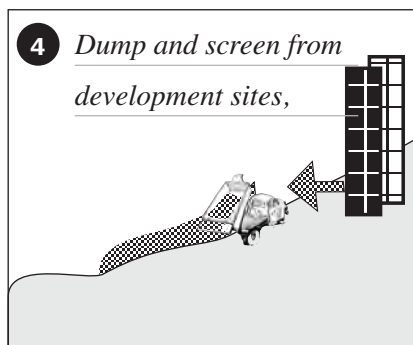
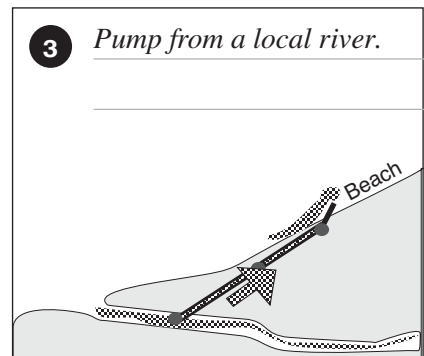
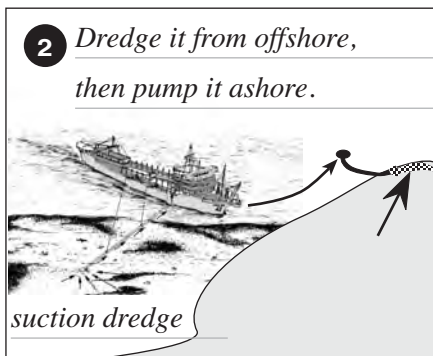
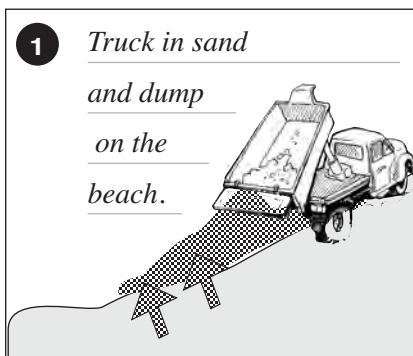
Read pages 111-119 of your textbook and the article on the page opposite to answer the questions below.

### Questions

Q1. Define the term beach nourishment.

*Beach nourishment is the process by which sediment (usually sand) lost through longshore drift or erosion is replaced on a beach.*

Q2. Complete the diagrams below to illustrate six methods of beach nourishment.



Q3. Research which of the six methods above have been used on the Gold Coast (or your local area). State when and where these may have occurred.

1. Trucking in the early 1960's at surfers

2. Bilinga beach in early 1990's

3. Continually at narrowneck just before Indy to prevent erosion

4. Wherever development occurs with 200 m of the beach

5. Continually at the Spit and Tweed River

6. Every Gold Coast beach as part of dune management system

Q4. List any 5 environmental issues associated with beach nourishment.

- dredging may kill animals and plants, and modify seafloor habitats

- burial of plants and organisms (invertebrates, shellfish)

- blockage of light in water (coral reefs) or toxicity of sediments

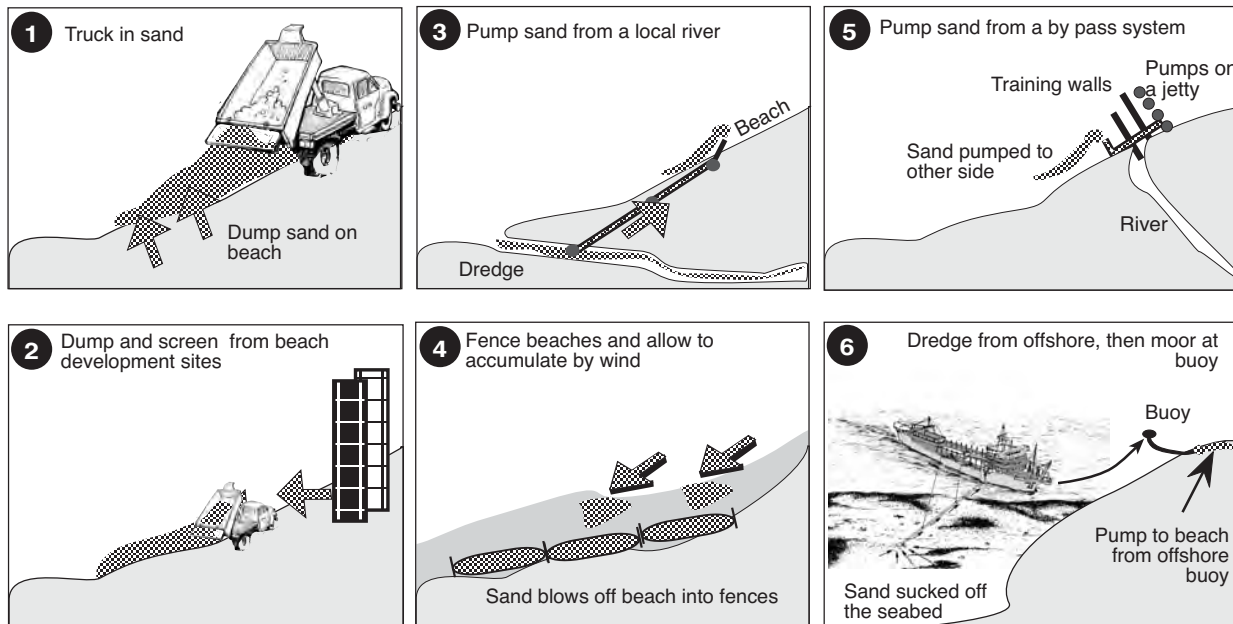
- dredging too close to shore can cause erosion

- changes critical habitat for nesting sea turtles and birds

- provides a false sense of security that increase development pressure

## Beach nourishment

(in all cases vegetation and walkways follow initial nourishment with sand)



*“Beach nourishment\* is a complementary term that describes a process by which sediment (usually sand) lost through longshore drift or erosion is replaced on a beach. It involves the transport of the nourishment material from one area to the affected area. This process is often expensive (minimum of \$1 million/km), depending upon the source (and thus the cost) of the sand.*

*Beach nourishment is almost always used as part of a coastal defence scheme. A poorly-designed and/or executed beach nourishment project can result in a severely impacted ecosystem, regardless of how much care is taken to deal with the sustainability of the littoral environment.*

*Once a beach is nourished, it almost always is necessary to regularly renourish it since nourished beaches tend to erode faster than natural beaches. The economic activity generated through beach tourism may compensate for the cost of both capital and maintenance beach nourishment works, but only in a small number of heavily urbanized areas.*

### Primary functions

- Provide protection to backshore property.
- Increase the recreational space along the shore.
- May replicate natural coastal processes by augmenting coastal sand budgets.
- Sediment texture (grain size and sorting) is critical for success. Sand fill must be compatible with native beach sand.

### Environmental issues

- Dredging may cause short-term direct mortality to sessile organisms, modifies seafloor habitats and sedimentary character.
- Burial of plants and organisms (invertebrates, shellfish).
- Blockage of light in water (coral reefs).
- Toxicity of sediments.
- Dredging too close to shore can cause erosion.
- Changes critical habitat for nesting sea turtles and birds.
- Provides a false sense of security that increase development pressure.”

\*Modified from [http://en.wikipedia.org/wiki/Beach\\_nourishment](http://en.wikipedia.org/wiki/Beach_nourishment). Note students would read carefully the way this encyclopedia works. This information may have changed since publication.

Q5. Describe the function of the Tweed River entrance sand by pass system.

*The system collects sand from the southern side of the Tweed River entrance and pumps it under the river to outlets on the northern side. From there the sand is transported by wave currents to nourish southern Gold Coast beaches. The project periodically dredges sand that accumulates at the Tweed River entrance. This sand is also transported to southern Gold Coast beaches.*

Q6. Recall the project's two objectives.

*a. establish and maintain a safe, navigable entrance to the Tweed River.*

*b. restore and maintain the amenity of beaches on the southern Gold Coast of Queensland.*

Q7. Describe the engineering (pipes, pumps, outlets etc) system.

*• a 450m sand collection jetty, located 250m south of the Tweed River entrance*

*• 10 submersible jet pumps supported by the jetty that sit below the sea bed and collect sand*

*• a water intake on the river's southern bank, that supplies water to operate the jet pumps*

*• a control building located on Letitia Spit which houses the pumps, electrical equipment and controls.*

*From here, sand slurry is pumped northwards under the river*

*• 3.1km of 400mm diameter steel and polyurethane underground pipeline which transports the sand to one of the discharge outlets*

*• discharge outlets located at East Snapper Rocks and West Snapper Rocks. Intermittent outlets are also used at Kirra Point and Duranbah.*

Q8. Justify the inclusion of safe navigation in the project's aims.

*To stop boating accidents on the Tweed Bar.*

*Allow safe entry in rough weather.*

Q9. List 10 criteria that would contribute to the definition of the term beach amenity.

*Clean water*

*Flagged areas*

*Domestic animal control*

*Beach access*

*Good surf break*

*Safe surfing*

*Good swimming - able to dive under waves*

*Litter free*

*No germs in water*

*Sand dunes and vegetation, birds in the trees*

*Showers*

*Rubbish bins*

*Car park, bike way, bbq pits, toilets*

*Safe environment - no perverts etc.*

## Tweed River Entrance Sand Bypassing Project

Modified from Tweed River Bypassing project information sheets: Ref: <http://www.tweedsandbypass.nsw.gov.au>

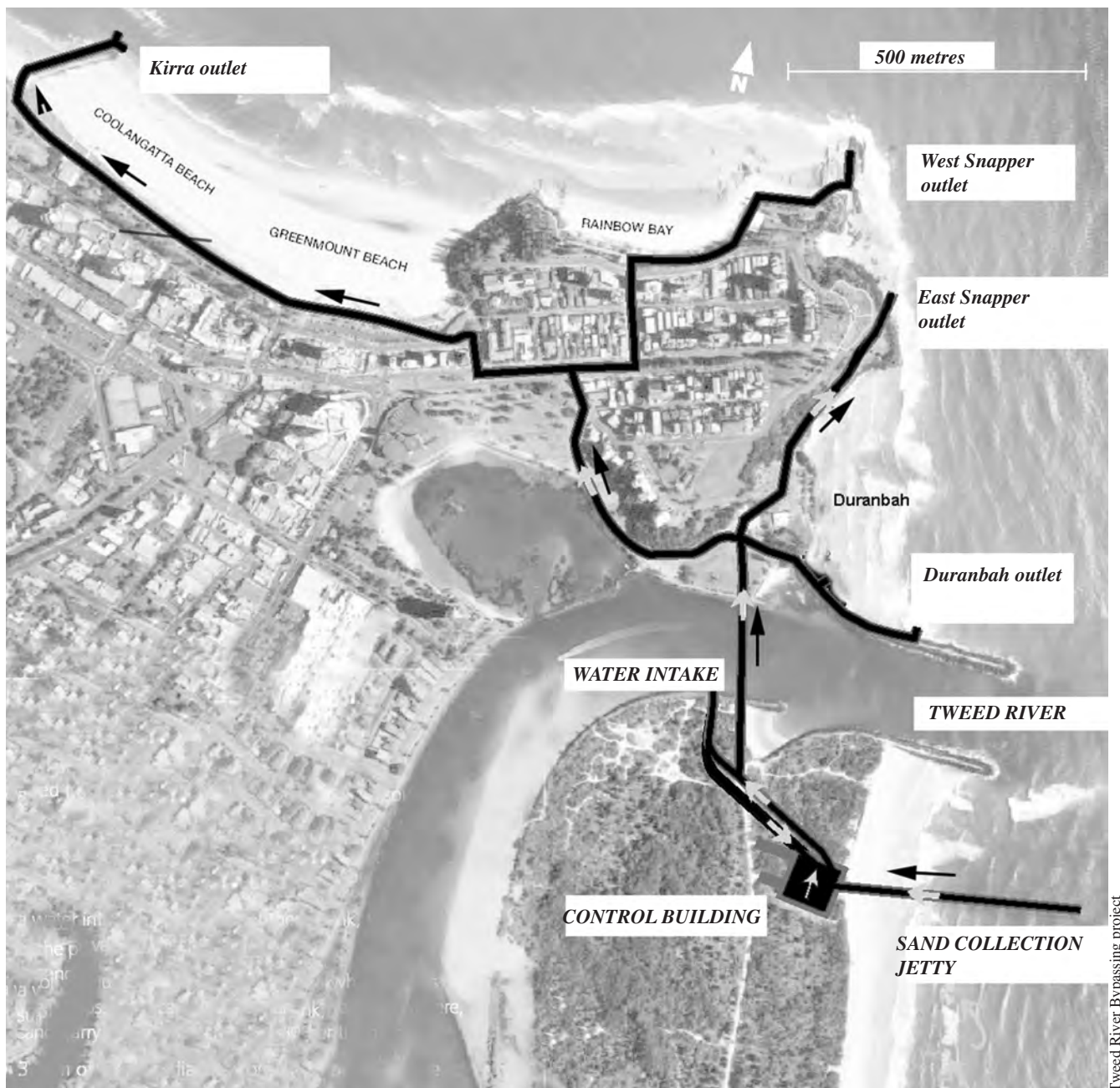
The project is a sand transport system that collects sand from the southern side of the Tweed River entrance and pumps it under the river to outlets on the northern side. From there the sand is transported by wave currents to nourish southern Gold Coast beaches.

The project periodically dredges sand that accumulates at the Tweed River entrance. This sand is also transported to southern Gold Coast beaches. The system is designed to transport the natural quantities of sand that move northwards along the coast. The project's objectives are to:

- establish and maintain a safe, navigable entrance to the Tweed River
- restore and maintain the amenity of beaches on the southern Gold Coast of Queensland.

### The sand bypass system consists of:

- a 450m sand collection jetty, located 250m south of the Tweed River entrance
- 10 submersible jet pumps supported by the jetty that sit below the sea bed and collect sand
- a water intake on the river's southern bank, that supplies water to operate the jet pumps
- a control building located on Letitia Spit which houses the pumps, electrical equipment and controls. From here, sand slurry is pumped northwards under the river
- 3.1km of 400mm diameter steel and polyurethane underground pipeline which transports the sand to one of the discharge outlets
- discharge outlets located at East Snapper Rocks and West Snapper Rocks. Intermittent outlets are also used at Kirra Point and Duranbah.



## B16. Can we make a model to identify coastal ecosystems?

An original exercise by Bob Moffatt

### Aim

To make a model of Kirra reef and southern points from the early 1930's to:

- identify and count local coastal features and ecosystems.
- define and locate high energy coastlines.

### You will need

- Southern points template from page opposite
- Stanley knife or sharp scissors, carbon paper, 2 cardboard boxes, gardening gloves, glue, clear acetate (OHT) sheet, cling wrap, pen and colouring pencils.

### What to do

**Safety warning:** Read and follow your school's safety sheet on cutting cardboard with paper cutting knives or scissors and make sure students wear protective gloves.

1. Write the following place names on your template. Pacific Ocean, Rainbow Bay, Greenmount, Tweed River, Kirra Point, Kirra Reef. Identify the contour lines 10, 20 m for Point Danger, Greenmount and Kirra Hill.
2. Identify the ocean contour lines -20, -15, -10, -5, -3 and the shoreline 0. Note the -20 m is the border and base of the model.
3. Using the paper cutting knife or scissors, cut out two pieces of cardboard the size of an A4 sheet of paper.
4. Using carbon paper so that it will transfer an image to the cardboard (Figure 46.2), take a pen and trace around the 20 m contour line. Now cut this out and glue it to the first sheet.
5. Using Figure 46.1 as a guide, continue until you have made to level 0. Now stick Point Danger, Greenmount and Kirra Hill together to show the land features.
6. Using gladwrap wrap up your model over the 0 contour line to show sea level. (Or take a clear acetate sheet)
7. Using blue tac, stick down Point Danger, Greenmount and Kirra Hill on top of the sheet.

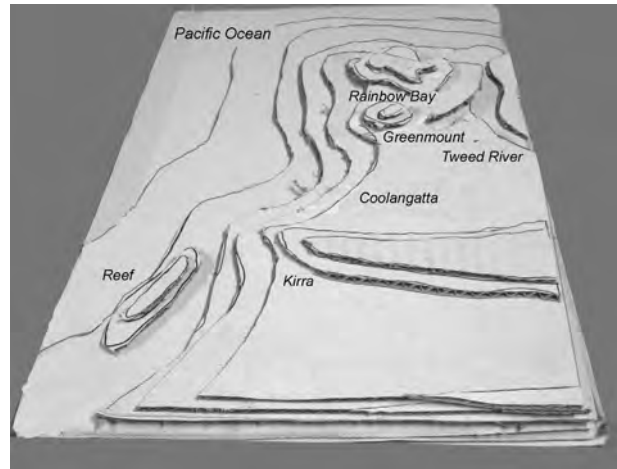


Figure 46.1 Completed model

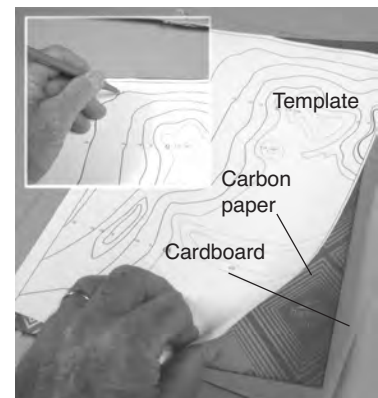


Figure 46.2 Making an outline

### Questions

Read page 84 - 88 of your textbook and answer the questions below.

- Q1. List the ecosystems that impact on Kirra and note where they are found in your model using Figure 84.1 of your textbook as a guide. How many did you get?

*Rocky reef (Kirra Reef), Rocky headland (Snapper, Greenmount, Kirra),*

*Estuary (Tweed River), Temperate Seagrass (in Tweed River)*

*Wave cut platform (Froggies Beach), Embayment (Rainbow Bay and used to be Greenmount)*

*High Energy Coast (Greenmount - Kirra - Bilinga), Intertidal Shore (Snapper, Froggies, Lovers)*

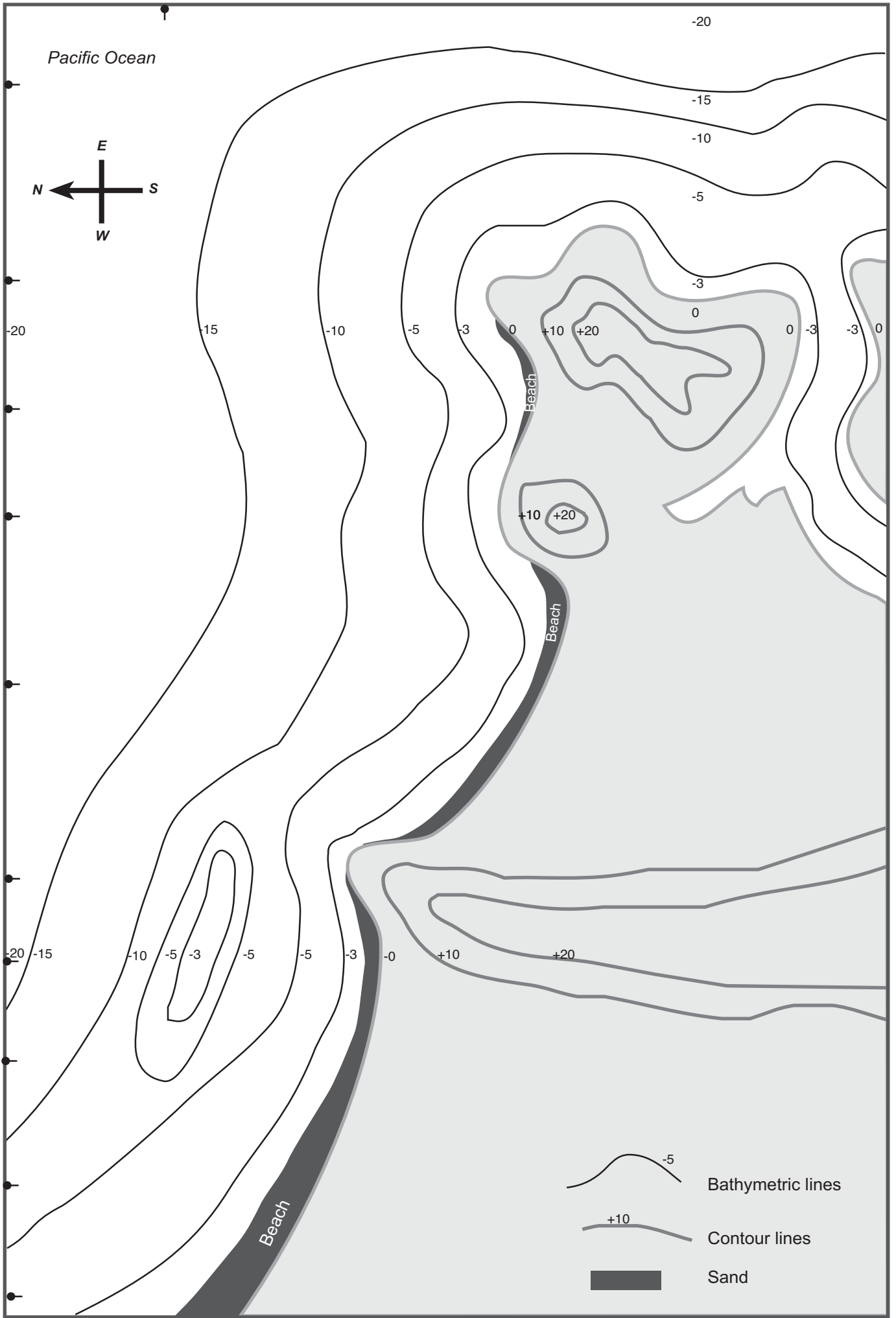
*Mangroves (Tweed River), Coastal Strip (Bilinga) TOTAL 10*

- Q2. Define the term high energy coast and identify it on your model.

*These are areas affected by wind generated waves. The whole of the model*

- Q3. There are times when seawater turns cold overnight and it is full of nutrients. What coastal feature in Figure 84.1 would most likely be responsible for this.

*Current gyre.*



## B17. Can we use a template to show wave refraction?

An original exercise by Bob Moffatt

Follow the campaign to Bring Back Kirra  
www.kirrapoint.org  
www.surfrider.org.au

### Aim

To make an outline on a clear acetate sheet to demonstrate wave refraction and attempt to predict wave shape from different wind directions.

### What to do

- Use a pencil to join the dots along line K to show a wave breaking on Kirra Beach.
- Complete the waves along lines A - J as shown in the insert on the page opposite, then copy this onto an acetate sheet.
- Now read pages 47 to 48 of your textbook and answer the questions below.

### Questions

- Q1. Explain why waves bend as they wrap around a headland.

*The seafloor absorbs the wave energy but as the seafloor is at different depths, one part of the wave travels faster than the one closer to the shore.*

- Q2. Prove this using a ruler, pencil and the completed worksheet from the page opposite.

*Draw a tangent to any wave line, for example waves C and D and then construct a right angle to each to touch the next wave. The right angle from page 47 of your textbook is called an orthogonal.*

*The deep water orthogonal (A)*

*is longer than the one in shallow*

*water (B) and so must have travelled*

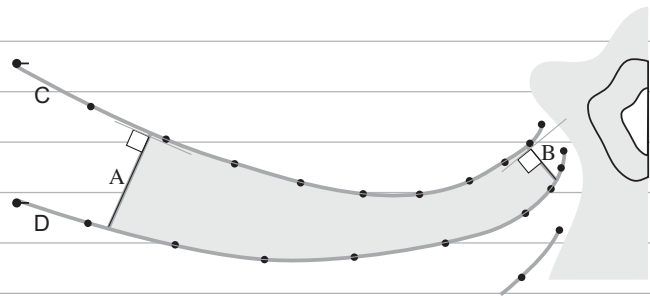
*further in the same time.*

*The deep water wave is therefore*

*travelling faster.*

*Ask your maths teacher to come up*

*with a proof.*



- Q3. Predict how a south easterly swell will refract around the Points of Snapper, Greenmount and Kirra. Use a felt pen to illustrate your answer.

*Students mark refraction on their own model*

- Q4. If sand is being carried around Snapper point, mark on your template where sand will be deposited.

*Sand will accumulate in the bays but NOT around the points*

*Sand in Rainbow Bay, Greenmount and Kirra*

- Q5. If you have been able to make an outline of the waves on an acetate sheet (OHP sheet), try moving it around over the model to show swells and wind from different directions to predict the movement from sand.

*A south easterly swell could move the sand west faster than a northerly swell*

*A north swell with a north east wind could move sand onto the beach*

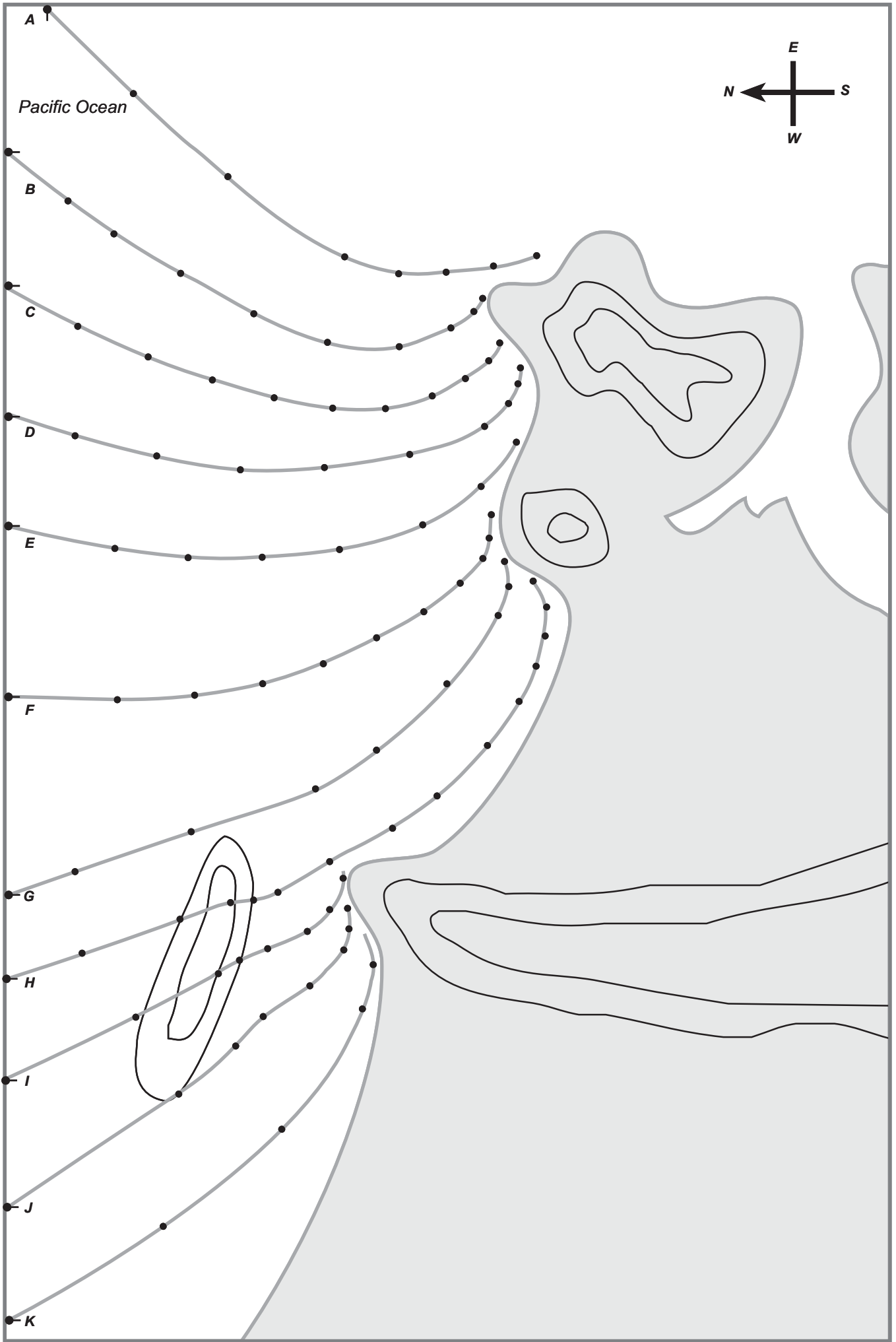
*A westerly would flatten the surf and blow sand out to sea*

- Q6. What is wave reflection and predict where it will occur on your template.

*Wave reflection is where the wave bounces back on itself ie reflected backwards*

*Anywhere where the wave strikes parallel to a headland (eg Froggies)*







## C2. How much salt is in seawater?

An original exercise by Bob Moffatt

### Aim

To describe the concentration of seawater.

### What to do

- Read pages 131 and 139 of your textbook, complete the diagram opposite and answer the questions below.

### Questions

Q1. Complete the diagram opposite to illustrate the composition of seawater salts.

Q2. Define the term salt concentration.

*Salt concentration is the number of grams of salt dissolved in water.*

Q3. Recall the average salinity of seawater.

*35 grams per litre (g/L)*

Q4. Describe two ways salinity varies in the sea. Use examples to illustrate your answer.

*Evaporation and rainfall can change the salinity of an area. The Red Sea reaches high salinities*

*due to lack of rainfall. The Baltic Sea has a low salinity due to melting ice and freshwater inflow.*

*Depth - the deeper the ocean, the more steady the salinity. Drops off from 37ppt or 34ppt at surface to 35 ppt at 4000 metres depth.*

Q5. Define the term salt water wedge and describe how and where it can happen.

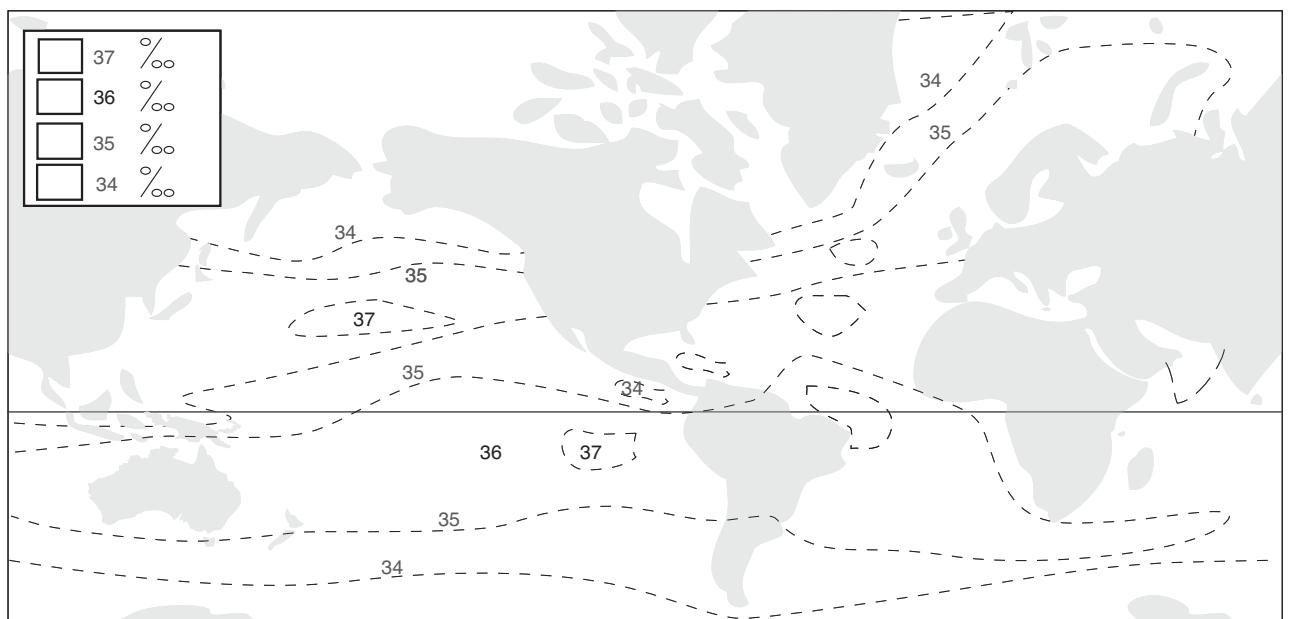
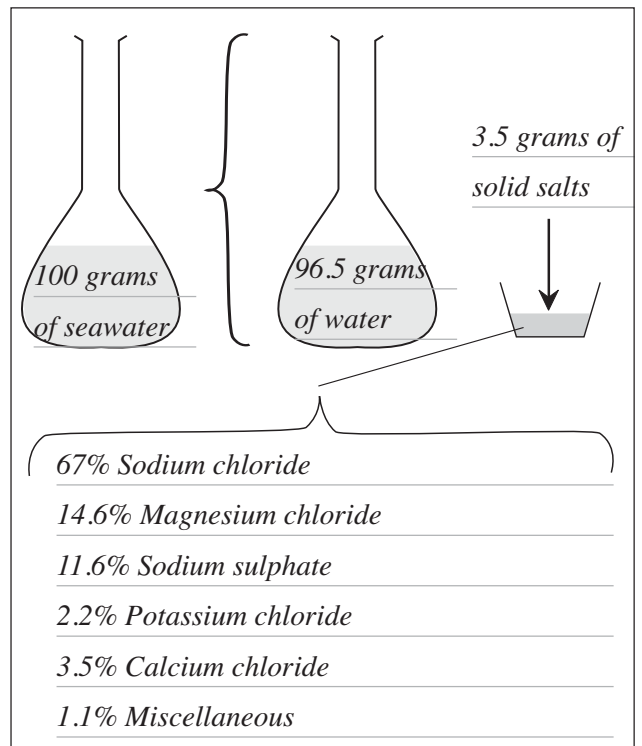
*A salt water wedge is the part of the water column that forms a boundary between water of different salinities. It can occur at a river mouth as the less dense fresh water runs over the incoming sea water of higher salinity.*

Q6. Describe what would happen if you went up a river and analysed water samples for salinity.

*You will be able to see a marked decrease in salinity.*

Q7. Define the term isohaline. Complete and colour in the diagram below to show differences in world salinity.

*Isohalines are lines that join places of the same salinity.*



### C3. Can we make and establish a test for seawater?

#### Aim

To make a series of seawater samples and determine a test for salinity.

#### What to do

#### Part A

- Read pages 136 - 137 of your textbook and answer the questions below.

#### Questions

Q1. Define the terms PPM and g/L.

*PPM is the number of parts per million,*

*g/L is grams per litre*

Q2. Suppose your group is required to make up 200 mLs of salt solution containing 35 g/L. Calculate how much salt you should weigh out.

*If 35g of salt make up a 1000 mL solution,*

*then 7 grams of salt make up a 200 mL*

*solution.*

Q3. Complete the table above for the entire task.

Q4. Define the term titration.

*Titration is a process of determining the amount of a certain substance present in a solution by measuring the amount of a different solution of a known concentration that must be added to complete a chemical change.*

Q5. Describe what happens at the end point.

*The exact point of which the entire chemical has been used up during the reaction between two substances is called the end point.*

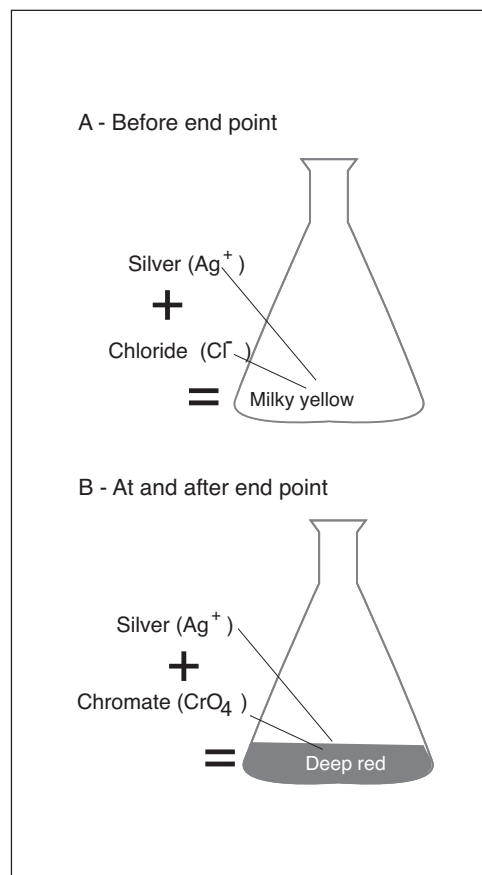
Q6. Name the solutions used in this experiment.

*Silver nitrate, potassium dichromate, salt water*

Q7. Describe how they will be used to determine end point. Copy the illustrations from page 135 of your textbook to illustrate your answer.

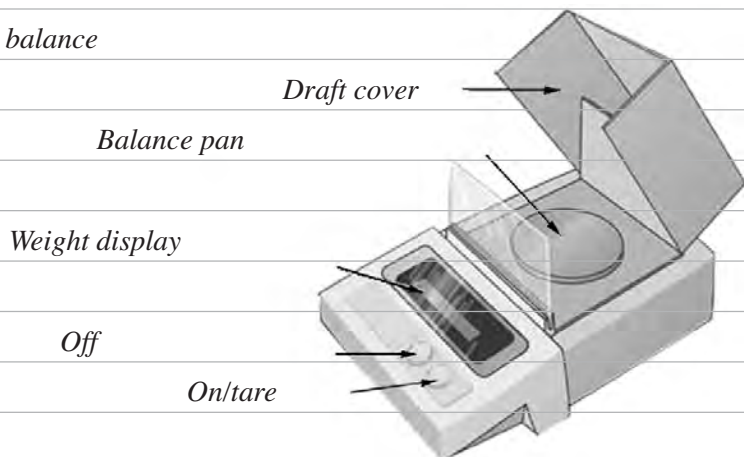
*The silver in the silver nitrate reacts with the chloride in sodium chloride before it will react with chromate in the potassium dichromate. While this is happening silver chloride is being made and the solution will stay milky. As this happens small red spots will appear as the silver nitrate drops hit the milky solution. When one drop causes the solution to stay red, the end point is reached and the silver now starts to react with the chromate to form silver chromate. The number of drops, should approximately equal the number of grams per litre.*

Sample	Weight of salt (g/L)	Weight of salt (g/200mL)	Concentration
1	5	1	5 000 ppm
2	10	2	10 000 ppm
3	15	3	15 000 ppm
4	20	4	20 000 ppm
5	25	5	25 000 ppm
6	30	6	30 000 ppm
7	35	7	35 000 ppm
8	40	8	40 000 ppm

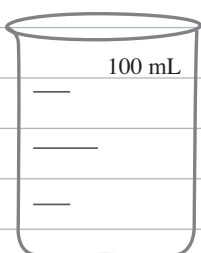


Q8. Draw and identify the equipment used in this experiment.

*Electronic balance*



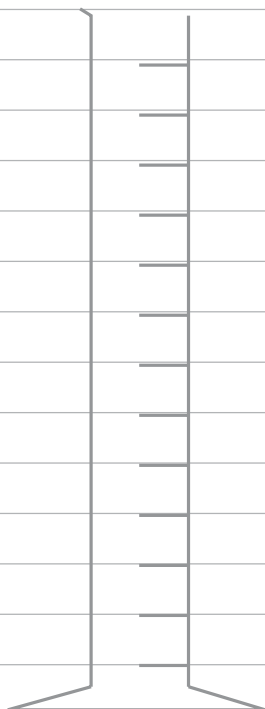
*100ml beaker*



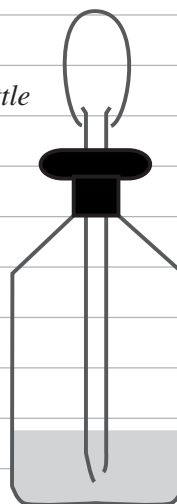
*Conical flask*



*Graduated cylinder*



*Reagent bottle*



*Eye dropper*



## Part B

- Complete the experiment on page 136 of your textbook and answer the questions below.

### Experimental notes

- Because eye droppers vary from manufacturer to manufacturer, you will need to keep the same sized eye droppers for future tests. The eye dropper needs to deliver about .1 mL.
- Potassium dichromate is a health risk and should be used carefully and in drops only from a well marked bottle.
- Silver nitrate is hazardous and causes staining of the hands. Gloves must be worn during this experiment.

### Questions

- Q1. How many drops of your gm/Litre saltwater solution were added to the conical flask?

*20 drops*

---

- Q2. Recall the name of the indicator solution.

*Potassium dichromate*

---

- Q3. How many drops of this indicator were added to the seawater and what colour did it turn?

*3 drops were added to turn the seawater yellow.*

---

- Q4. Describe what happens to the salt solution as the silver nitrate is added.

*As it is added, a red patch is formed. When the solution is swirled it disappears initially.*

---

*The dark red patches hang around for an increasingly longer time.*

---

- Q5. Describe what happens at end point.

*When one drop turns all the seawater a reddish brown*

---

- Q6. Record the number of drops to end point in Figure 55.2 (data table 1) on the page opposite beside the g/L entry.

- Q7. Collect the results from the other groups noting the number of drops to end point for each and add these to the table.

- Q8. Draw a calibration graph in the space provided in Figure 55.3 on the next page. What does this graph show?

*The determination of salinity using the eye dropper technique.*

---

- Q9. Now use the unknown samples to determine their salinity. Record your results in Figure 55.2 (data table 2) on the page opposite.

- Q10. Describe the graph you have drawn.

*Line of best fit, increasing with salinity*

---

- Q11. What is the salinity of the unknown samples?

*Students own results*

---

---

---

- Q12. List and explain any experimental errors.

*Eye droppers of different sizes leads to different drop volumes of silver nitrate*

---

---

---

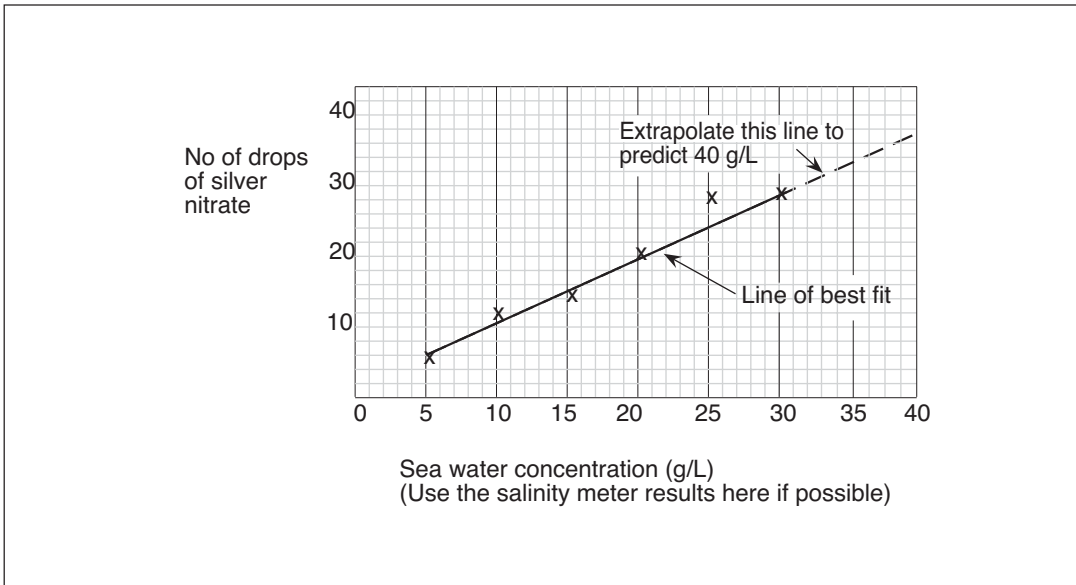


Figure 55.1 Sample calibration graph

Data table 1		Data table 2		
Standard solution	Number of drops of silver nitrate to end point	Sample site (e.g. boat harbour near ramp)	Number of drops of silver nitrate to end point	Salinity in mg/L
5 g/L				
10 g/L				
15 g/L				
20 g/L				
25 g/L				
30 /L				

Figure 55.2 Results

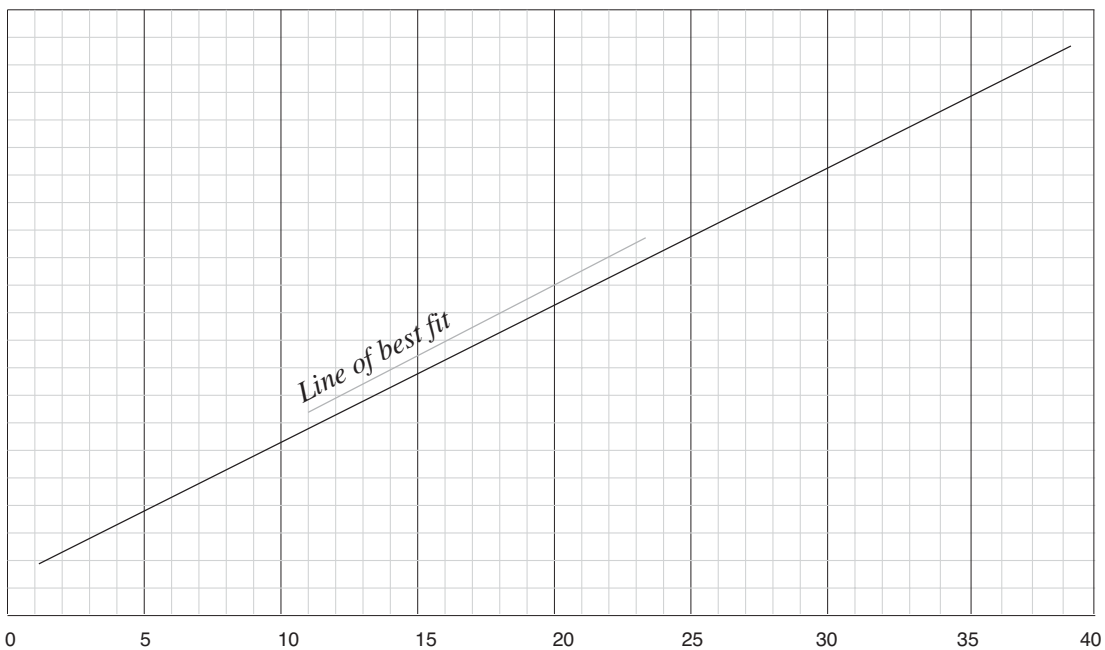


Figure 55.3 Calibration graph drawn from class results.

#### **C4. Can we determine how much oxygen there is in seawater?**

##### **Aim**

- To measure the percent saturation of dissolved oxygen in seawater.

##### **What to do**

- Complete the experiment on pages 178 - 179 of your textbook to determine the percent saturation of oxygen in a seawater sample. Then answer the questions below.

##### **Questions**

Q1. Make a list of the materials you could use in this experiment.

*HACH dissolved oxygen kit, temperature and salinity meters, safety goggles and rubber gloves*  
*seawater sample*

Q2. Write out the experimental method in the space below.

*1. First collect a seawater sample in a bucket and measure the temperature and salinity*

*2. Submerge the DO bottle in the water. Incline the bottle slightly and gently stopper the bottle while it is still under the water so no bubbles enter the bottle.*

*3. Tap down the chemicals in sachet number 1 and shake its contents into the DO bottle.*

*4. Repeat for sachet number 2 in the same bottle.*

*5. Collect a small amount of sample water in the square mixing bottle and use it to wash out any chemicals in the neck of the DO bottle.*

*6. Re-stopper the bottle carefully, tipping the small quantity which escapes into the waste bottle.*

*7. Hold the bottle and stopper, move away from the group and rotate the bottle.*

*3 times to dissolve the chemicals in it. Allow the sample to stand for 5 minutes.*

*8. Use the clippers or scissors to tap down the chemicals in sachet number 3.*

*9. Remove the stopper from the bottle and add the chemicals from the sachet and carefully re-stopper the bottle and rotate. The floc should dissolve and a yellow colour will develop if oxygen is present.*

*10. Fill the plastic tube with the prepared sample then empty the tube into the square mixing bottle.*

*11. Open the sodium thiosulphate solution by reading the instructions on the neck of the bottle.*

*- Add sodium thiosulphate solution drop by drop to the bottle, swirling to mix after each drop.*

*- Hold the dropper vertically above the bottle and count each drop as it is added.*

*- Continue to add drops until the sample changes from yellow to colourless.*

*- Record the number of drops on your result sheet.*

Q3. Use the graph over and follow points 13 and 14 on page 178 of your textbook to determine the per cent saturation of oxygen in the seawater sample. Record this in the box in Figure 57.1

Q4. What values of per cent saturation did your other group members get?

*For a good sample 90-100 or greater*

Q5. Decide what could cause levels of per cent saturation to fall.

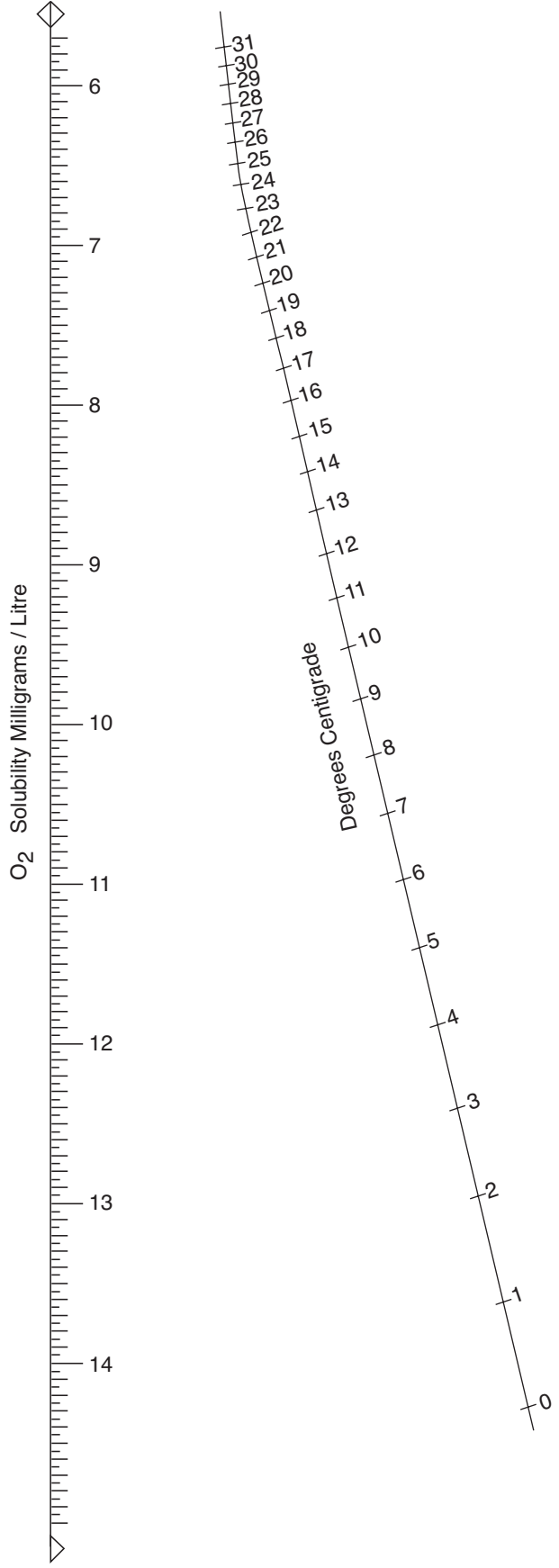
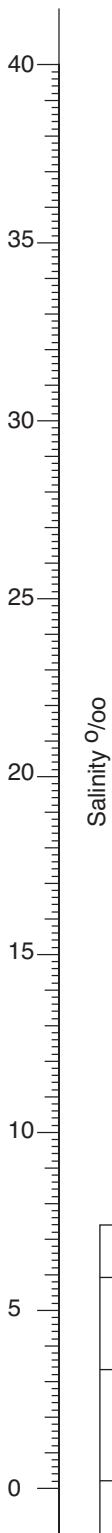
*Heat, pollution*

Q6. Discuss how we could manage the marine environment to prevent decreases in oxygen levels.

*Pollution control from point sources eg power stations*

*Stormwater control*





O<sub>2</sub> Solubility Milligrams / Litre

Data for calculations	
Salinity of seawater sample	Temperature
Oxygen solubility at that temperature (from above graph)	
Recorded solubility (No of drops)	
$\text{Percent saturation} = \frac{\text{Recorded solubility}}{\text{Oxygen solubility at that temperature}} \times 100 =$	

Figure 57.1

## C5. What effect does marine pollution have on dolphins?

An original exercise by Anna Cook

### Aim

To highlight how rubbish and pollution in the sea harms dolphins.

### What to do

- Read the information on the page opposite, play the fatal food relay game and answer the questions below.

### Questions

Q1. Describe five ways dolphins hunt for food.

*Herding - where they work together to surround a school of fish, and then take turns swimming through, while eating all the fish they can.*

*Coralling - where they herd a school of fish into shallow water, to make it hard for the fish to escape.*

*Whacking - where they strike fish with their tails, in order to stun the fish, so they can eat it.*

*Stunning - where they will send a very loud CLICK! through the water at the fish.*

*The loud noise will shock the fish, and leave it stunned.*

*Foraging - Where they will pick up a sponge, and use it to push through the mud on the bottom of shallow parts of the ocean, looking for food.*

Q2. Name the marine food used in the game and suggest other food dolphins might eat.

*Barramundi, whiting, mullet, sea jelly, octopus, starfish, crab*

*Other invertebrates found in the benthos*

Q3. Complete the table below linking the type of food that killed the dolphins in the game and the feeding and reason.

<i>Type of feeding affected</i>	<i>Fatal food type</i>	<i>Possible reason for death</i>
<i>Foraging</i>	<i>Ring pull cans</i>	<i>Choking while trying to swallow food</i>
	<i>Broken glass</i>	<i>Cutting mouth while trying to pick up food</i>
	<i>Fishing line</i>	<i>Choking</i>
	<i>Cans</i>	<i>Choking</i>
	<i>Plastic bags</i>	<i>Choking, block blowhole</i>
	<i>Discarded needles</i>	<i>Cutting mouth poisoning</i>
	<i>Oil</i>	<i>Poisons vital systems</i>
<i>Stunning</i>	<i>Fishing line</i>	<i>Wraps around stunned fish</i>
	<i>Dumped chemicals</i>	<i>Poisons vital systems</i>
<i>Coralling</i>	<i>Fishing line</i>	<i>Choking</i>
	<i>Cans</i>	<i>Choking</i>
<i>Herding</i>	<i>Fishing line</i>	<i>Choking</i>
	<i>Cans</i>	<i>Choking</i>
<i>The list is not definitive</i>		

## Fatal food game

### Materials

- 2 brown paper bags or small boxes
- Good food - 8 pictures/drawings of sea food creatures or cards with names of sea creatures – eg squid, crabs, octopus, fish, sea jelly, plankton, krill
- Fatal food - 8 samples of rubbish eg balloon, plastic bags, foam, six-pack ring, fishing line, drink can



### What to do

1. Assign one member of the class to read out loud the dolphin feeding notes from the shaded box below.
2. Form two equal relay teams of dolphins and name each.
3. Mark an area and arrange brown bags or boxes (with the hidden food inside) at the end of the relay course. Use the illustrations below to make up the food.
4. Each relay member is to run to the end of the relay course and select a bag.  
The team member should open the bag and show it to the instructor but no one else.
5. If the bag has fatal food in it, the team member should moan, groan then go to the sick and dying section off to one side.  
If the bag has good food in it the team member will go back to their relay team.
6. Repeat the activity until all team members have gone or only one team is remaining. The last team left healthy is the winner.

### Dolphin feeding and pollution

Dolphins are active predators and eat a wide variety of fish, squid, and crustaceans such as shrimps and food available can vary with its geographic location and season. For example;

- Coastal dolphins tend to eat fish such as cod, mackerel, mullet or bait fish and bottom-dwelling invertebrates such as starfish or crabs.
- Offshore dolphins tend to eat fish and squid.

Some fish, such as mackerel or herring, have a lot of fat in them. This means that a Dolphin will get a lot of energy from eating these fish. However, squid does not have much fat, so a Dolphin has to eat more squid to get the same kind of energy it would get from fish. On average, however, a 250 kg dolphin will typically eat between 10 kg and 22.5 kg of fish every day. Five ways dolphins can collect food are:

**Herding** - where they work together to surround a school of fish, and then take turns swimming through, while eating all the fish they can.

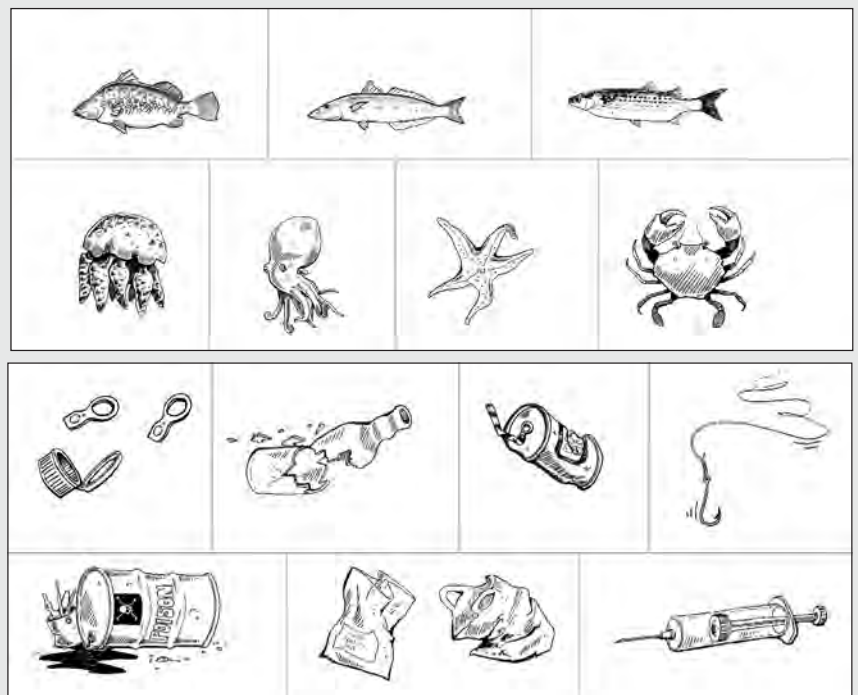
**Coralling** - where they herd a school of fish into shallow water, to make it hard for the fish to escape.

**Whacking** - where they strike fish with their tails, in order to stun the fish, so they can eat it.

**Stunning** - where they will send a very loud CLICK! through the water at the fish. The loud noise will shock the fish, and leave it in a stunned.

**Foraging** - Where they will pick up a marine creature such as a sponge, and use it to push through the mud on the bottom of shallow parts of the ocean, looking for food.

Common types of pollution that affects dolphins are ring pull cans, broken glass, cans, fishing line, oil and chemicals dumped, plastic bags and discarded needles.



## C6. Why is DDT a problem in the marine food chain?

Based on an original exercise by Tim Ryan, Maryborough State High School.

### Aim

To explain the effects of chemical pollution in the sea.

### What to do

- Read the information on the page opposite and answer the questions below.

### Questions

Q1. Describe why scientists talk about the poison pyramid in describing the problems of DDT.

*This refers to the fact that DDT accumulates in the food chain from one trophic level to the next.*

---

Q2. Explain how insects eventually became resistant to DDT even when the original recorded kills were 99%.

*It only takes for a very small percent (eg. 1 percent) in a population develop resistant genes to the spray. This 1 per cent reproduces to give say a 5 per cent resistance and before you know it, a significant percentage of the population has resistant genes.*

---

Q3. Describe how it was possible for DDT to save over millions of lives in malaria affected countries. How did DDT affect the transfer of infectious diseases?

*DDT killed mosquitos which were the carriers of the malaria. Wipe out the mosquitos and you wipe out the malaria. The mosquito has a saliva gland which contains the infectious disease. Its the saliva gland which stops the blood from clotting when the parasite feeds off your skin and this is the place where the transfer takes place.*

---

Q4. Explain why some of the effects of DDT on human population are not yet known and why it has taken so long to find out.

*The testing of chemical effects on humans has to be over the long term. Some chemical take a long time to show their effects. Eg, the side effects of the contraceptive pill took a long time to become known.*

---

Q5. Calculate the concentration of DDT increase as you move up the food chain.

*About 20 times*

---

Q6. Describe how we could control insect pests if we are not to use chlorinated hydrocarbons.

*We could try biological control where we find a natural predator. Attitudes also play a role - by reducing the sex or food supply or breeding grounds, you can reduce population sizes. Eg. Sterilize males, get rid of places where water accumulates – eg old car tyres, buckets or pot plants. Pour oil on water (in some places)*

---

Q7. Recall where Dieldrin has been a problem and what it has been blamed for.

*In waterways and has been blamed for the deaths of fish*

---

Q8. Describe one step that must be taken if history is not to repeat itself with the introduction of new and different insecticides.

*You need exhaustive scientific testing and computer modelling.*

---

Q9. Recall the advantages of DDT. What other types of insecticides have been developed?

*It was quick and almost 100% effective.*

*2-4-D.*

---

Q10. Decide who should pay for the cost of cleaning up the DDT mess. Give a reason for your answer.

*The government as they failed to legislate against its use.*

---

Q11. It has been estimated that for the last 25 years 1,400,000 tonnes of DDT eventually found its way into the sea annually. Calculate how much DDT would now be in the sea?

*25 x 1 400 000 = 35 000 000 T*

---

## Read this

### **DDT in the food chain**

After the Second World War the scientists began to develop synthetic chemical pesticides.

They developed the chlorinated hydrocarbon insecticides, of which DDT is the best known. DDT was developed by the Swiss scientist, Paul Muller, and it earned him a Nobel Prize in 1948.

DDT was extensively used in agriculture in the 1950's and 1960's to control all kinds of insect pests and allow huge increases in food production.

It was believed that DDT had no effect on other animals.

DDT saved millions of lives in malaria affected countries. Unfortunately, the full effects of DDT on the environment and animals were not noted until the late 1960's.

DDT is nonbiodegradable and is strongly resistant to chemical action and does not dissolve in water.

When an animal eats another animal containing DDT, most of this DDT is absorbed and dissolves in the fatty tissue where it remains until it dies.

Therefore once DDT is sprayed on crops it will eventually be washed into the rivers and creeks. Here it will then find its way into aquatic plants and phytoplankton.

The concentration in these plants is mostly very small and does not affect them.

High concentrations affect their photosynthesis and may stunt their growth.

The animals which eat these plants accumulate DDT in their bodies as shown on the following table.

DDT has a serious effect on these animals. It can cause:

- a. some birds to become sterile eg, pelicans
- b. the egg shells to become thin and easily broken
- c. the embryo's growth to slow down
- d. the production of sex hormones to stop

DDT can also build up in the human population. Mother's milk has been shown to contain more than 4 times the accepted level for fresh milk in some communities. DDT can also cause liver damage, stunted growth and nervous problems.

Source	DDT Concentration in parts per million
bottom sediment	0.00006
phytoplankton	0.06
zooplankton	0.4
predatory fish	8
predatory birds	240

### **Web reference**

You can read the complete article on the problem of chlorinated compounds in Australia's marine environment by Bruce J. Richardson, School of Biological and Chemical Sciences, Faculty of Science and Technology, Deakin University, Geelong, Victoria 3217 at

<http://www.ea.gov.au/coasts/publications/somer/chapter4.html>

### **How could we control insect pests if we are not to use chlorinated hydrocarbons?**

We could try biological control where we find a natural predator.

Attitudes also play a role - by reducing the sex or food supply or breeding grounds, you can reduce population sizes. Eg. Sterilize males, get rid of places where water accumulates – eg old car tyres, buckets or pot plants. Pour oil on water (in some places).



## C7. What are some of our seas contaminated with?

Based on an original exercise by Tim Ryan, Maryborough State High School. Acknowledgement is given to the Australian Fisheries Management Authority for permission to reproduce the article from Australian Fisheries.

### Aim

To describe some effects of heavy metal pollution.

### What to do

- Read the information on the page opposite and answer the questions below.

#### Article update

Check out the annual report on Australia's heavy metal pollution at <http://www.environment.gov.au>

### Questions

- Q1. Suggest eight sources of contamination in St Vincent Gulf.

*Cadmium, copper, lead, zinc, sewage, litter, detergents, oil*

- Q2. To determine an estimate of the trace elements in St Vincent Gulf by water analysis was labour intensive and time consuming. Give a reason why and how the levels of contamination were determined.

*Diffuse inputs (ie non-point source), variable wind and current conditions. However you could speed this up by analysing marine organisms. By using marine organisms.*

- Q3. Name the types of organisms that were examined in this study.

*Fish, molluscs and plants*

- Q4. Recall which metal trace elements were investigated.

*Cadmium, copper, lead, zinc*

- Q5. Recall what the letters NHMRC stand for.

*National Health and Medical Research Council*

- Q6. In which tissue of the fish were the highest levels of zinc found? Suggest an explanation for the results.

*Gills - this is the place for oxygen-water exchange.*

- Q7. Tabulate the NHMRC recommended levels of lead in fish, zinc in molluscs and copper in crustaceans.

<i>Lead in fish</i>	<i>Zinc in molluscs</i>	<i>Copper in crustaceans</i>
<i>7.5 mg/Kg</i>	<i>5 000 mg/Kg</i>	<i>350 mg/Kg</i>

- Q8. Decide if any of the levels of trace elements found in the examples exceed the maximum recommended concentrations of the NHMRC and give an example.

*Yes - Eg, molluscs cadmium in muscles*

- Q9. Calculate the weight of copper found in a sample of 3 kg (dry weight) of fish muscle.

*1.53 – 3.9 mg*

- Q10. Calculate the expected range of weight of zinc found in 10 kg of living mollusc muscle.

*360 – 600 mg*

- Q11. Compare the trace metal value found in St Vincent Gulf with Cockburn Sound (WA). Determine if any of the levels at Cockburn Sound (WA) are above NHMRC recommended levels.

*More cadmium, more copper, less zinc in fish at Cockburn Sound compared with St Vincent Gulf*

*In general, Cockburn Sound is more polluted.*

- Q12. Would you expect trace metal levels to increase in organisms as you go up the food chain? Explain your answer. Did this occur at St. Vincent Gulf in all cases? If not, suggest a possible reason for this observation.

*Yes due to bioaccumulation effects.*

*No – cadmium decreased, copper decreased, lead decreased, zinc however increased.*

*Possible behaviour of trace elements and requirements for muscle metabolism.*

## Metal contamination of St Vincent Gulf

The St Vincent Gulf marine ecosystem is subject to urban and industrial wastes from a major industrial centre - Adelaide. There is also some agricultural runoff. Such inputs are known to contain trace metals and are likely to lead to an increase in the concentrations of trace metals in the coastal zone, some of which are toxic and may endanger human health.

However, obtaining a realistic estimate of the level of trace metal contamination in the Gulf by water analysis is laborious and time consuming. Diffuse inputs and variable wind and current conditions make it necessary to analyse a large number of samples to obtain a reliable estimate of the extent of trace metal pollution.

Alternatively, the analysis of marine organisms provides a rapid and relatively inexpensive way of obtaining an estimate of trace metal contamination as marine organisms concentrate trace metals over a period of time, providing a time-averaged measurement of trace metal input.

A study has been undertaken to ascertain whether common species of molluscs, crustaceans, fish and marine plants contain concentrations of trace metals hazardous to public health and to establish the general level of trace metal pollution in the Gulf.

Molluscs, crustaceans and marine plants were collected from coastal areas south of Adelaide. A summary of the trace metal levels found in marine organisms is given in Figure 63.1.

Fish species included *Silliaginodes punctatus*; *Arripus georgianus*; *Hyporhamphus australis* and *Platycephalus bassensis*. Molluscs included *Pecten alba*; *Septoteuthis australis* and *Haliotis ruber*. The crustaceans analysed were *Panaeus latisuleatus* and *Portunus pelaguis* while four species of marine plants were analysed: *Posidonia australis*; *Posidonia sanuosa*; *Ecklonia radiata* and *Ulva sp.*

### Results

All trace metals were well below the National Health and Medical Research Council (NHMRC) maximum recommended concentrations. Cadmium and lead concentrations, usually good indicators of anthropogenic inputs, were all low.

Although high concentrations of copper were found in some molluscs and crustaceans, molluscs and crustaceans can contain high copper concentrations under natural conditions due to storage of copper in proteins and the presence of haemoglobin in blood.

Comparison of trace metal values with those measured in marine organisms from other areas of Australia known to be subject to urban and industrial influences revealed that metal concentrations are low indicating little measurable metal pollution in St. Vincent Gulf. Cockburn Sound in WA was found to be more polluted.

Article by Dr. W. Maher, lecturer at Canberra College of Advanced Education.

Trace metal concentrations in marine organisms from St Vincent Gulf, South Australia				
Marine organism	Heavy metal mg/Kg (dry wt)			
	Cadmium	Copper	Lead	Zinc
<b>Fish</b>				
muscle	<0.25	0.51-1.3	<.02-.05	15-55
liver	<0.25	0.70-6.0	<.02-.061	20-88
gills	<0.25	0.72-4.0	<.02-.096	50-110
n=28				
<b>Molluscs</b>				
muscle	<0.25-.51	0.81-24	0.52-0.96	36-60
viscera	<0.25-1.93	2.7-91	0.56-2.1	30-101
n=24				
<b>Crustaceans</b>				
muscle	0.11-0.5	5.7-15	0.31-0.71	16-36
viscera	0.1-2.1	24-28	1.3-1.4	55-58
n=11				
<b>Seagrasses/macroalgae</b>				
n=23				
NHMRC recommended levels*	0.1-.78	1.5-3.8	0.2-3.6	24-73
Fish	1	50	7.5	750
Crustaceans	0.25	50	7.5	750
Molluscs	10 (0.05-2)*	350 (0.70)	12 (1.5-2.5)	5000 (150-1000)

\*Converted to dry weight assuming 80% moisture. ( ) \* are wet weight levels.

Figure 63.1 From Australian Fisheries March 1986 (Reproduced with permission)

## C8. What effect does oil have on feathers?

Based on an original idea by Erna Walraven with assistance from Derek Spielman.

### Aim

To study the effect of oil pollution on feathers.

### What to do

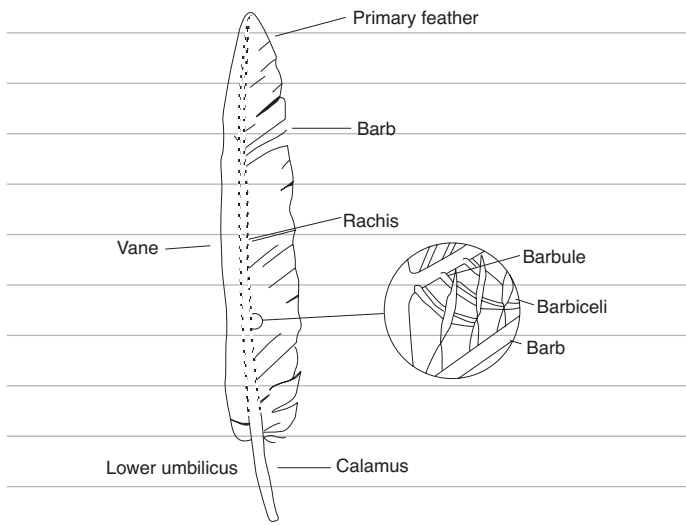
- Read the bird feathers information in the box to the right.
- Complete the experiment on the page opposite and answer the questions below.

### Questions

Q1. Describe the effect of oil on feathers.

*It causes the primary feathers to stick to the barbs.*

Q2. Make a drawing of the parts of a feather in the space below.



Q3. Describe how hypothermia effects birds.

*It can kill them.*

Q4. Explain why trained people are required to wash birds after an oil spill.

*So they don't harm the birds.*

Q5. Determine if birds are warm blooded.

*Yes*

Q6. Research who pays for washing oil-coated birds in your state.

*Students have to research this. Many places such as animal welfare leagues (eg RSPCA), receive some government funding to help look after animals. In some states National Parks and Wildlife Officers are paid to help clean birds.*

Q7. Research who has the national plan in place to prevent oil spills.

*Varies from AUS and NZ. Australian Marine Safety Authority co-ordinates oil spills. NZ equivalent unknown.*

### Bird feathers

The bird picks up on its beak some of its own natural preening oil. This is produced in a gland near its tail. Then the bird pulls its feathers through its beak, coating the feathers with oil, "zipping" up the barbules to make them waterproof. This makes the feathers strong enough for flight.

Birds' feathers are waterproof partly because of their structure and partly because birds preen their feathers with oils. Waterproof feathers insulate the bird - they protect the bird from cold and keep it dry and warm.

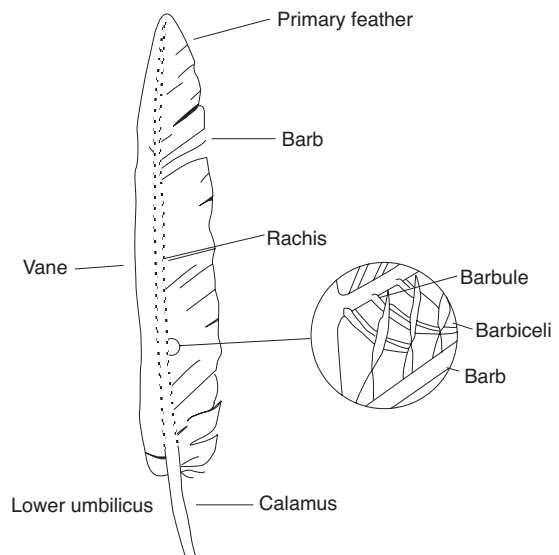
Unnatural oil destroys the insulating properties of feathers. If the feathers of a bird get clogged with oil from a spill, the bird can't fly, float or keep warm. The body temperature drops (hypothermia) which may kill it.

Rescuers wash the oil off the feathers with detergents. But detergents also wash off the bird's preening oils. A bird treated with detergents needs to be rinsed with water and looked after until its feathers are coated with preening oil again (about 2-4 weeks). If the bird is released before this, its feathers would become waterlogged and the bird would not be able to fly or feed or to keep warm.

When a bird is washed too roughly, its feathers can be damaged so that they cannot trap an insulating layer of air. Then the bird must be kept until the damaged feathers are replaced by new ones. This can take up to a year.

Birds are only one of many kinds of animals that can be affected by an oil spill.

This exercise demonstrates how feathers are naturally waterproof and the effects of oil and detergents on feathers. Detergents are used to remove oil from birds affected by a spill.

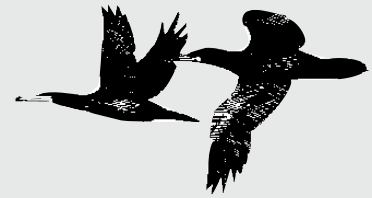




## Experiment

### Materials and equipment (per group)

- feathers
- a glass
- water
- cooking oil
- detergent



### Note:

- Use feathers that have been recently discarded, are clean, but not fluffy. Waterbird feathers work best if you can find them.

### What to do

1. Fill a glass with clean water as shown in the figure below.
2. Dip a feather in and look into the glass. When you pull the feather out, it will be mostly dry. The trapped air layer makes the feather waterproof.
3. Make an oil spill by pouring some cooking oil onto the water surface.
  - The floating oil may form a thin layer as it spreads out.
  - This is what happens to oil when it is spilt in the sea if the weather isn't rough.
4. Push the feather into the water through the oil. How does the feather look now?

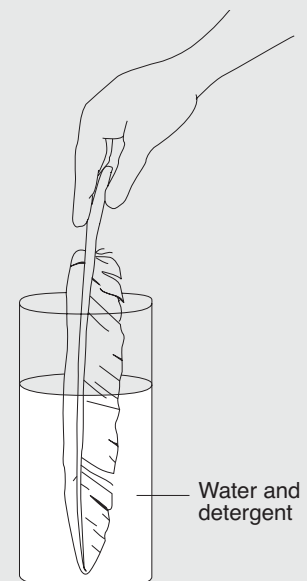
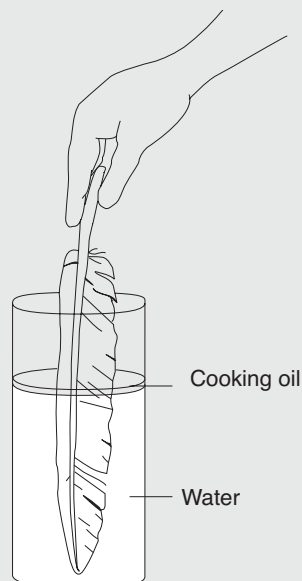
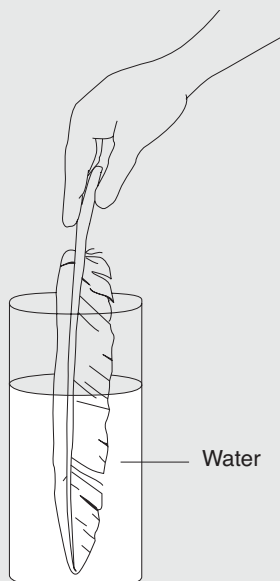
---

---

---



5. Pull the feather out of the glass. You'll find it's covered in cooking oil.
  - The oil has stuck to the natural oils in the feather and clogged it.You will notice that the feather structure has been damaged.
6. Get a clean glass and pour water into it. Add some detergent. Push a new feather into the detergent and water mixture.
7. Pull the feather out.
  - Notice that it is completely soaked in water.
  - The detergent removed the natural oils from the feather so that it is no longer waterproof and does not maintain its fine structure.



## C9. What happens in an oil spill?

Based on an original idea by Bob Moffatt

### Aim

To study the effect of an oil spill on a Hypothetical Bay.

### What to do

- Read the newspaper article in the box opposite and answer the questions below by using the internet and class discussions.

### Questions

- Q1. A tonne of oil will take about 10 minutes to form a slick of about 0.5 mm thick and 500 metres in diameter.

If the *Collintina* has been losing oil for 10 hours, calculate the size of the oil slick it will have produced.

Rate of oil loss

$$= 1 \text{ tonne per minute} = 60 \text{ tonne per hour}$$

If time = 10 hours

Oil lost = 600 tonne

Area of 1 tonne

$$= \pi r^2 = 3.14 \times 250^2$$

$$= 196\,250 \text{ m}^2$$

$$= 443 \text{ m} \times 443 \text{ m}$$

Notes: Total area covered after 10 hours

$$= 117\,749\,400 \text{ m}^2 = 10.8 \text{ km}^2$$

- Q2. Light oils such as petrol and diesel will evaporate almost completely in 4 hours. This crude oil from *Collintina* had some evaporation and samples suggest it will have lost 40% of its volume in 10 hours. Calculate the size of the slick.

The slick will be 60% of expected size

$$= 70\,650\,000 \text{ m}^2 = 8.4 \text{ km}^2$$

- Q3. Do you think that the slick will completely evaporate? Give a reason for your answer.

No. Oil is very viscous and will only dissolve in seawater.

- Q4. The danger of fire is greatest with lighter oils. Explain this statement.

Volatile liquids such as petrol and light oils evaporate very quickly and hydrocarbon is a gas which is very explosive and easy to ignite.

- Q5. Burning the oil is likely to be ineffective. Suggest why.

The burning of the oil is ineffective since it is not that volatile and does not completely evaporate) and the oil slick is so thin (0.5mm).

- Q6. List three methods that could be used to stop an ecological disaster.

a. Break up slicks with detergents

b. Soak up the oil from the surface

c. Stop the loss of oil from the ship.

## OIL TANKER STRIKES REEF



At 11pm last night the Greek Tanker *Collintina* lost its bow almost 6 miles east of the mouth of the Jensen River.

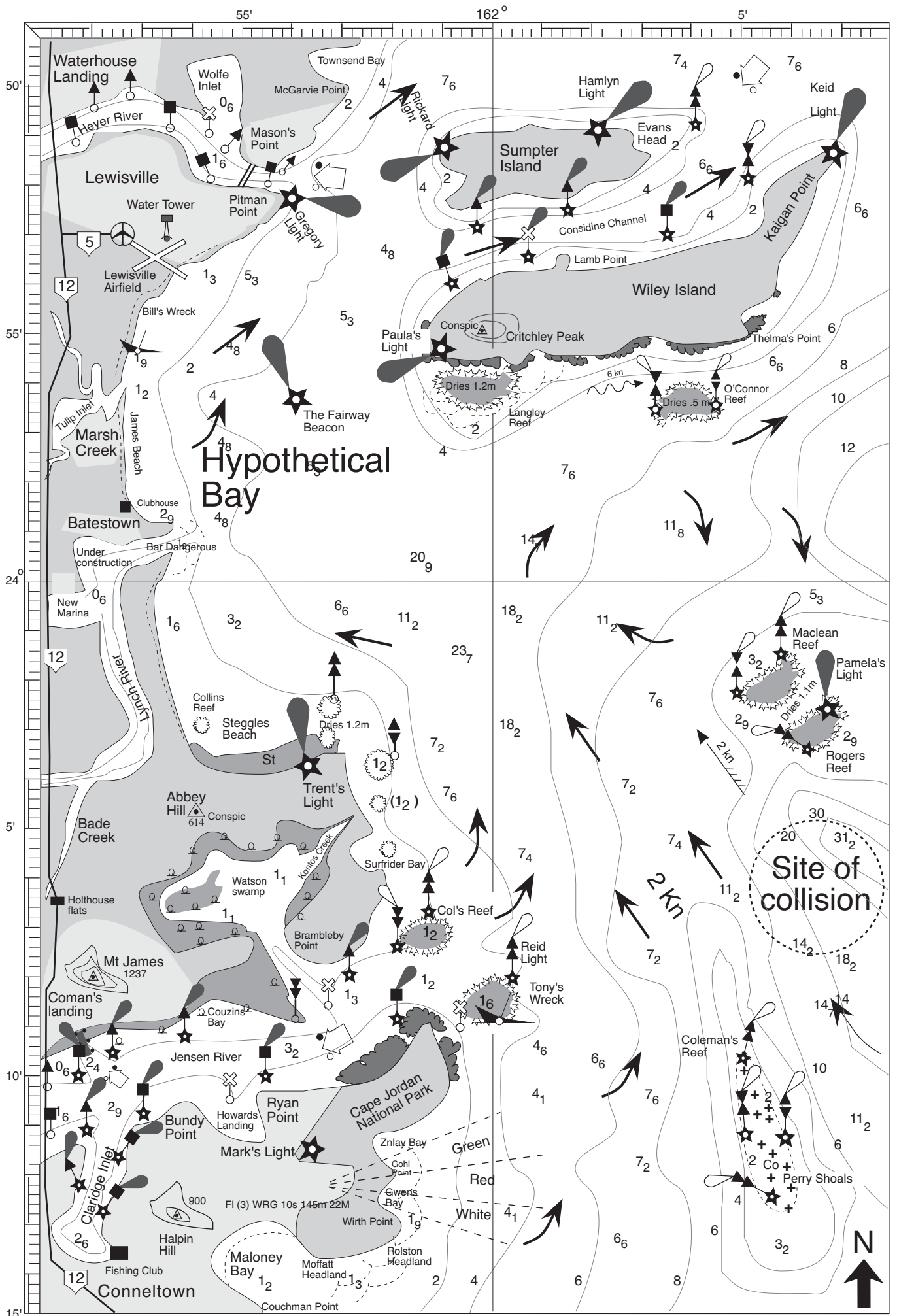
The crew of the *Collintina* abandoned ship. No serious injuries were reported even though fires or explosions have occurred. A rescue vessel has been sent to attempt to tow the tanker to a safe haven.

The oil tanker is carrying 20,000 tonnes of crude oil and was left with its bow cut off. The ship was losing oil at a rate of 1 tonne/minute.

Representatives from the Australian Maritime Safety Authority has been sent to the area to take control of the situation. The Federal authorities have set into action the national plan to combat the pollution of the sea by oil.

Equipment from all over Australia has been sent to the area to control the spill. This includes helicopter borne aerial spray units, booms and self propelled oil recovery vessels.

Turn over to complete this exercise



- Q7. Response authorities have only four 1 km booms to protect areas of the coast. Suggest areas where these should be deployed so that the least ecological damage occurs.

*Around Maclean and Rogers Reefs*

Explain why you have positioned the booms in these locations.

*To catch the oil as it comes from the south east*

*To protect the coral reefs and seabird rookeries*

Draw them onto the chart of Hypothetical Bay.

**Conditions on day of disaster:**

Winds: 20 knot easterly Seas: 1.5 - 2 metres

Tides: High 2.4 m (0600hrs); 2.6 m (1800hrs)

Low 0.2 m (1154hrs)

- a. Predict the movement of the slick. Explain your answer.

*The oil slick will move in a west north westerly direction. A current in the area will move the slick to the north west. The winds will move the slick to the west.*

*Approximate movement is west north west.*

- b. What areas of the tidal coastline will be affected and when will this happen. N.B. Oil slick moves at about 10% of the wind speed.

*The area expected to be most effected would be the coast north of Lewisville airport, including Pitman Point, Heyer River, Langley Reef and the south eastern port of Wiley Island.*

*The booms should be placed North West of the site where the collision occurred.*

- Q8. If the oil can be dispersed by aerial spraying of dispersants how will this help solve the problem? Do you believe these sprays should be used and what is the justification for using dispersants?

*Dispersal of the slick does not solve the problem it is just transferring the problem elsewhere.*

*Some people believe that if we see no evil there is no evil.*

*The problem disappears with spraying.*

*The dispersant may harm the environment even more than the oil itself.*

*Most organisms have natural oils which can be affected by the dispersants.*

- Q9. Some of the oil (particularly the lighter elements) can dissolve in water forming toxic compounds. Which type of marine life will be in most danger?

*Some marine organisms are bioaccumulators eg oysters, mussels.*

*Also organisms high on the food chain may be affected by the accumulation of the toxin.*

- Q10. The extent and amount of pollution damage may depend on the season. Suggest an explanation of this fact.

*Some animals migrate and may not be in the area.*

*The effect may be greater if it is in the animals breeding season.*

*Juveniles are more likely to be affected than adults.*

- Q11. Decide how sea conditions will affect the clean up operations.

*Large seas make containment harder. Heavy seas increase dispersal.*

- Q12. Explain how the type of oil will affect the movement of the spill.

*Light oils are more volatile and dispersed readily by winds.*

*It is also less viscous and will spread more easily.*

Q13. The On Scene Spill Model (OSSM) is a computer model that can be used to predict the movement of the oil spill. Suggest some local information that needs to be known to run the program.

*Ocean currents*

---

*Tidal flows*

---

*River flows*

---

*Local weather conditions*

---

Q14. Sea birds have a major problem if they become coated with oil.

a. Describe how oil affects them.

*Feathers become coated - loss of warm air under the feathers - bird suffers hypothermia.*

---

b. Describe how it affects their young.

*If young are still in nest and relying on adult for food and protection they will die.*

---

Q15. Mechanical removal is the best method of removing the oil from the shore. The removal is affected by the type of beach eg sand, pebble, rock and mud. Suggest some special problems each beach may present.

*Mud - hard for tractors and vehicles to move in this terrain - get bogged.*

---

*Rock - hard to remove oil from rock crevices and scrape off oil. The surface may not be flat.*

---

*Sand - vegetation that is stabilizing beach is also removed.*

---

Q16. Suggest other problems that may be encountered in beach or shore clean ups.

*Poor access to the beach*

---

*Isolated area*

---

*Lack of skilled personnel in the area*

---

Q17. Decide if mangrove areas should be cleaned mechanically. (errata - add justify your answer)

*No - there would be too much physical damage to habitat*

---

Recall the effect of the oil on the mangroves.

*Mangrove roots will be covered by oil and the roots will suffocate.*

---

Explain if dispersant sprays should be used to clean the area.

*There are points for and against spraying.*

---

Q18. Describe how nature can take care of oil pollution.

*Some bacteria can digest and break down oil.*

---

Q19. Suggest who should pay for the oil clean up operation and if the company owning the *Collintina* should pay compensation for destruction of the environment. Give reasons for your answer.

*The government is responsible for the cleanup.*

---

*The company should contribute to the funding.*

---

*Students own reasons.*

---

Q20. Debate your answers in class.

*Students conduct class debate.*

---

## C10. What impact do acid sulfate soils have on the sea?

An original exercise by Bob Moffatt

### Aim

To explain acid sulfate soils and list 10 effects on fish.

### What to do

- Read pages 168 - 169 of your textbook to complete and colour in Figures A, B and C on the page opposite to illustrate your understanding of acid sulfate soils. Then answer the questions below.

### Questions

Q1. Define the term acid sulfate soil.

*Acid sulfate soils (ASS) are the common name given to soils containing iron sulfides (principally iron pyrite) or products of the oxidation of sulfides.*

Q2. Explain what happened during the formation process.

*During the formation processes, sulfate in seawater was reduced by bacteria to iron sulfide (commonly known as iron pyrite) in waterlogged, saline sediments where there was a supply of easily decomposed organic matter, eg mangrove swamps and saltwater marshes.*

Q3. Explain what happens when the pyrite is exposed to air.

*The sulfite oxidised to form sulfuric acid and often releases aluminium.*

Q4. Describe how this is explained in Figures A and B on the page opposite.

*The water table is lowered, exposing the acid sulfides to the air.*

Q5. Explain how acid sulfate soils affect tourist development.

*The acid generated can seep into groundwater and surface waters, and if left unchecked, they can corrode steel and concrete and liberate toxic levels of aluminium, iron, and heavy metals from the breakdown of clays and silts.*

Q6. Complete Figure C on the page opposite and summarise the effects of acid sulfate soils 1 - 10 on marine life in the space below.

1. *Fish kills*

2. *Dominance of acid-tolerant fish species results in low species diversity*

3. *Altered plankton communities*

4. *Increase in fish diseases*

5. *Avoidance leading to overcrowding*

6. *Smothered fish eggs and benthos*

7. *Physical stress causing no spawning*

8. *Loss of spawning area*

9. *Loss of food resources and nursery grounds*

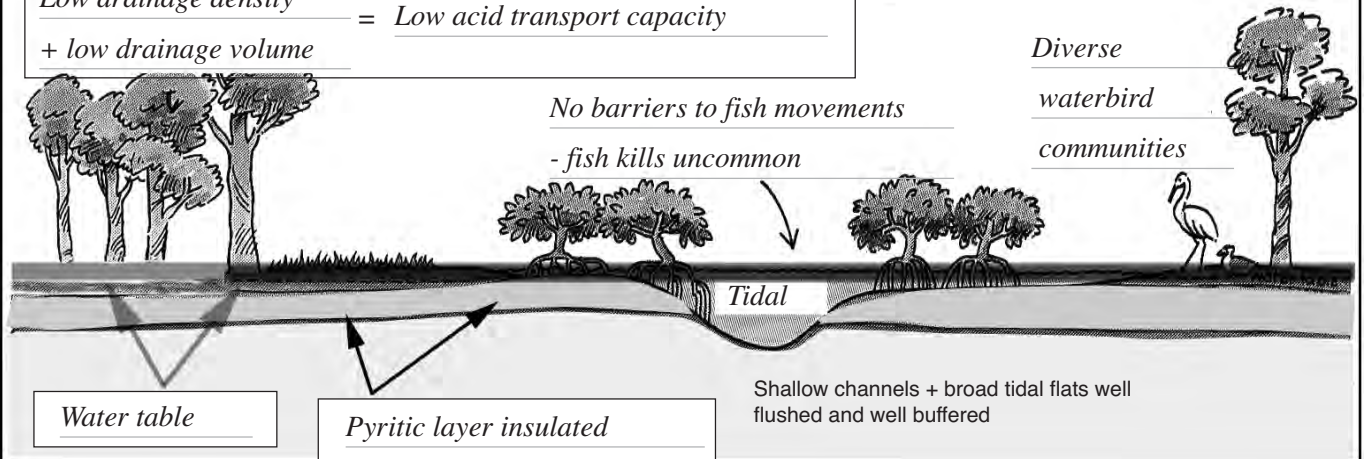
10. *Destruction of crustaceans*

Q7. Describe one environmental impact of acid sulfate soils.

*Any one from the column on page 168. Eg Red spot in estuarine or freshwater fish.*

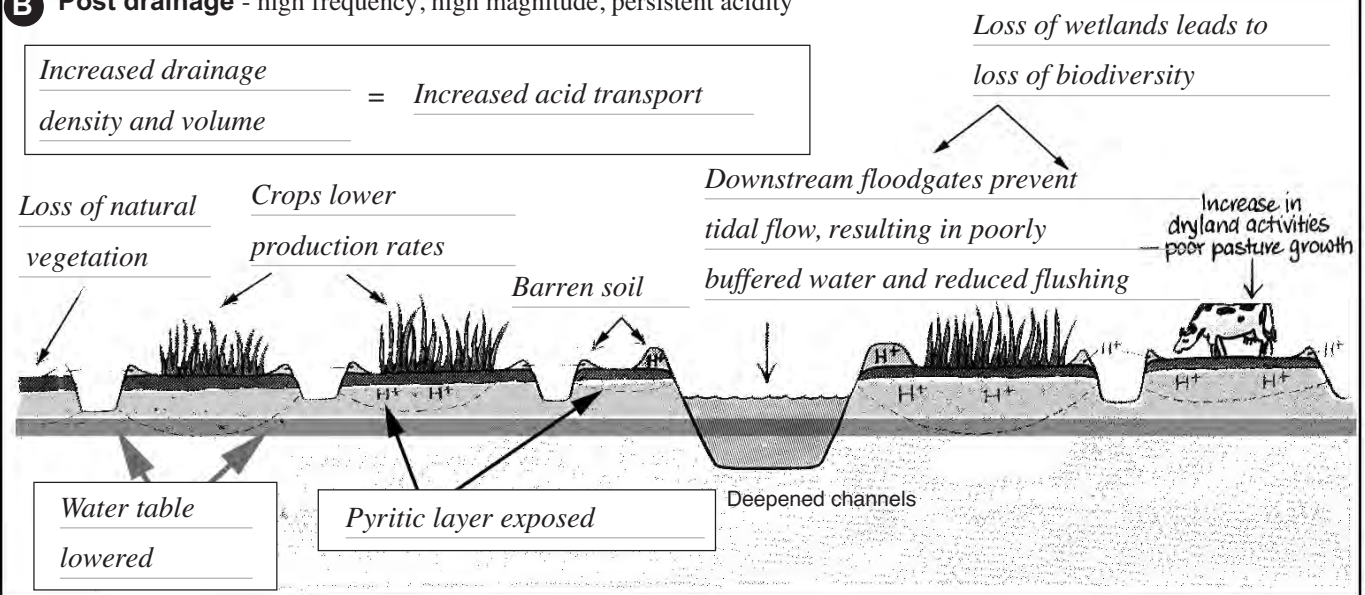
**A Natural setting** - low frequency, low magnitude, short duration acidity

Low drainage density = Low acid transport capacity  
+ low drainage volume

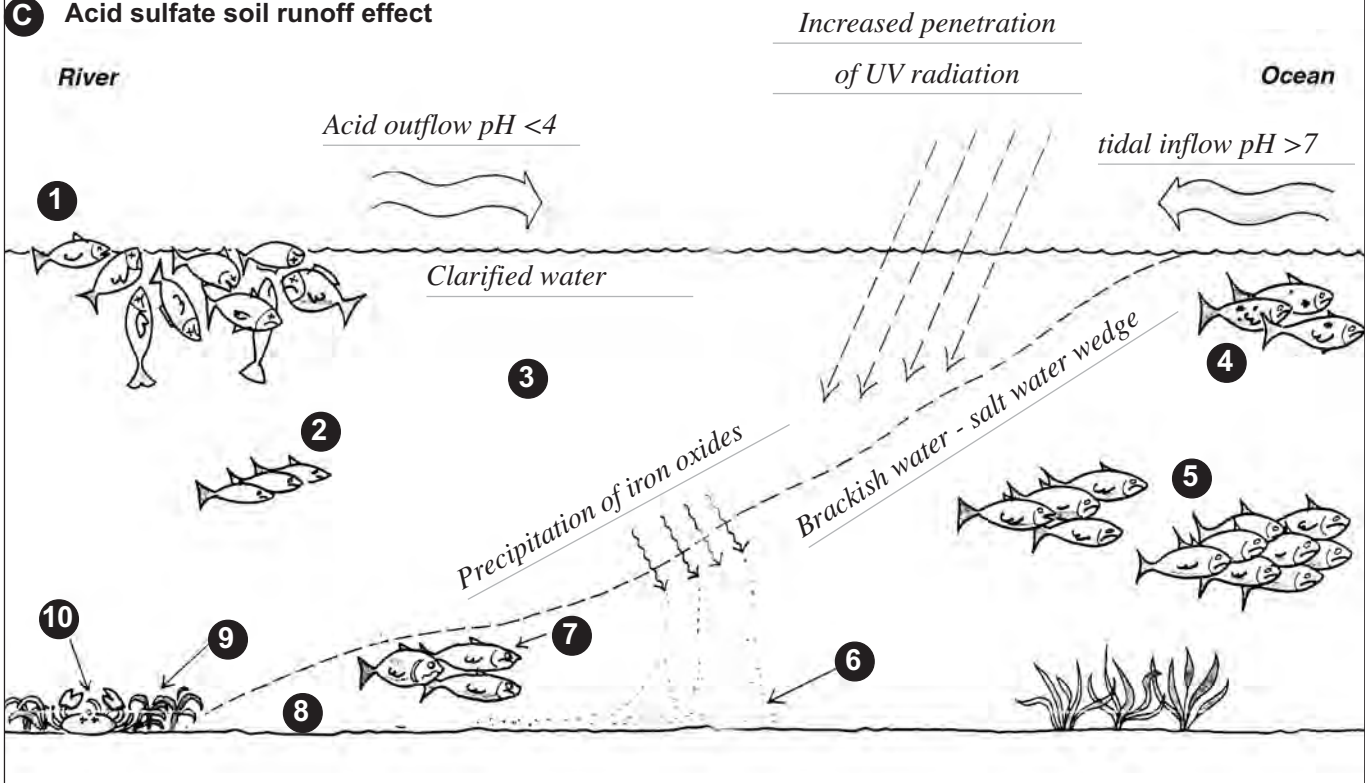


**B Post drainage** - high frequency, high magnitude, persistent acidity

Increased drainage density and volume = Increased acid transport



**C Acid sulfate soil runoff effect**



# C11. What effect does water quality have on the marine environment?

An original exercise by Bob Moffatt

## Aim

To analyse a report card on water quality in the marine environment.

## What to do

- Read pages 442 - 443 of your textbook, copy the information from Figure 443.1 into the table opposite and answer the questions below.

## Questions

Q1. List the four marine environments studied.

*Coastal rivers, Estuaries and coastal lakes, Nearshore coastal waters and bays, Ocean*

Q2. Suggest the difference between developed and undeveloped.

*Developed has cities and towns, undeveloped has national park or undisturbed by humans*

Q3. Explain the difference between the criteria for scores A - D.

*A - No detectable problems or trace levels of contaminants*

*B - Some problems or low levels of contaminants*

*or widespread low levels or few sites with moderate levels*

*C - Moderate problems or moderate levels of contaminants*

*or widespread moderate levels or some sites with high levels*

*D - Serious problems or high levels of contaminants or widespread high levels*

*or many sites with very high levels*

Q4. Compare the effect of sedimentation on coastal rivers, estuaries and coastal lakes, nearshore coastal waters and the ocean.

*Serious sedimentation in developed rivers and estuaries, but not so in the ocean*

Q5. Comment on pollution in your local area. Write a report card in the box opposite.

---

---

---

---

---

---

---

---

---

---

---

---

---

---

---

---

---

---

---

---

---

---

---

---

 <b>Report Card</b>		
Subject		
Pollution	Sources and effects	Level





# Report Card

**Subject:** Water quality and the marine environment

(A: excellent, to D: poor)\*

<b>Pollution</b>	<b>Sources and Effects</b>	<b>Level</b>
<b>Coastal rivers</b> Developed	<i>Moderate to serious sedimentation. Elevated nutrients from land use, sewage, pollutants from developed and industrial discharges, acid sulphate spoil run-off</i>	<u>C - D</u>
Undeveloped	<i>Increased sedimentation; elevated nutrients</i>	<u>A - B</u>
<b>Estuaries and coastal lakes</b> Developed	<i>Many estuaries eutrophic. Coastal lakes moderate to seriously eutrophic</i>	<u>C - D</u>
Undeveloped	<i>Possible minor sedimentation, elevated nutrients</i>	<u>A-</u>
<b>Nearshore coastal waters and bays</b> Developed	<i>Elevated nutrients eg SA Gulf, Vic Bays, NSW Bays Moreton Bay and possibly GBR</i>	<u>B - C</u>
Undeveloped	<i>Possible increase in sediments</i>	<u>A</u>
<b>Ocean</b> Developed	<i>Trace levels of chlorinated compounds (lower than Nth Hemisphere, but increasing towards coast</i>	<u>A-</u>
Undeveloped	<i>As above</i>	<u>A</u>

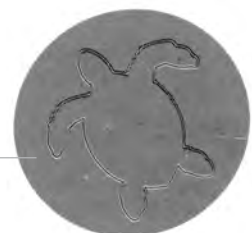
**\*Scores**

**A:** No detectable problems or trace levels of contaminants

**B:** Some problems or low levels of contaminants

**C:** Moderate problems or moderate levels of contaminants

**D:** Serious problems or high levels of contaminants



## C12. How can impacts of coastal development be minimised?

An original exercise by Bob Moffatt

### Aim

To analyse a development for a coastal town and make predictions of possible environmental consequences.

### What to do

- Read the news article below, compare pages 67 and 75 of this exercise book, and answer the questions below.

### Questions

Q1. Describe at least 20 proposed changes.

- |   |  |
|---|--|
| 1. New breakwater at mouth of Lynch River         | 2. New airport                           |
| 3. Freeway to new airport                         | 4. Merino Wharf                          |
| 5. Establishment of Steggles Beach Marine Reserve | 6. Fishers Wharf                         |
| 7. Dredging of Watson Bay                         | 8. Development of Marina city            |
| 9. Proposed harbour town on Lynch River           | 10. Building of O'Connor Bridge          |
| 11. New resort on island near Wright Point        | 12. New marina near mouth of Lynch River |
| 13. Boat ramp on Collins Creek                    | 14. Developing McRobbie causeway         |
| 15. Developing Watson Bay National Park           | 16. Developing Pattern Reserve           |
| 17. Developing Cadell National Park               | 18. Holthouse Flats development          |
| 19. Developing Harding Island                     | 20. Lynch River was dredged              |

Q2. Explain why the regional government banned all development along the coastline from Steggles Beach Reserve to Farmer Beach.

*This is a sand dune area and is continually being eroded and built up again by nature.*

*If development was to occur this would need development of sand stabilizing measures. It is a very fragile area.*

Q3. Propose alternatives to sewerage effluent being pumped at King Point.

1. Recycled - used a fertilizer on land
2. Undergo tertiary treatment

## Massive development proposed for bay

Tourism is one of Hypothetical Bay's fastest growing industries with many people escaping the cold winter in the northern hemisphere to bathe in its crystal clear waters.

Steggles Beach was voted beach of the year's in 2007 and has unparalleled attractions at the nearby Collins, Redden and McDonald Reefs. The proposed Watson Bay National Park is well renowned for its coastal flora and fauna including the world famous Smith Parrot.

In the 1970's Hypothetical Bay was a sleepy hollow and developed in the 80's and 00's to a stage as shown in the Figure opposite.

In 2001 Lynch River was dredged with the approval of a new marina south of Batestown.

A proposal is before the Batestown city council for a mega city and development. It is proposed to widen Bade Creek and build

a Fishers Wharf complex that will link Watson Bay by a causeway.

Watson Swamp will be dredged to create a massive foreshore development around the new Mariner City with an international airport that will take five flights from Japan each day.

The Regional Government has proclaimed that the entire foreshore from Steggles Beach be a reserve and to include Butler Beach to Farmer Beach and the Plattern Reserve.

The headland to the east of the airport is to be a national park and the sacred aboriginal sites to be managed by the local Warranda tribe and a permit to enter the national park will have to be obtained.

A new breakwater is proposed as well as an artificial island offshore, the details of which are not disclosed.

To the west of Lynch River is a Harbour Town development for an expected 100,000 people

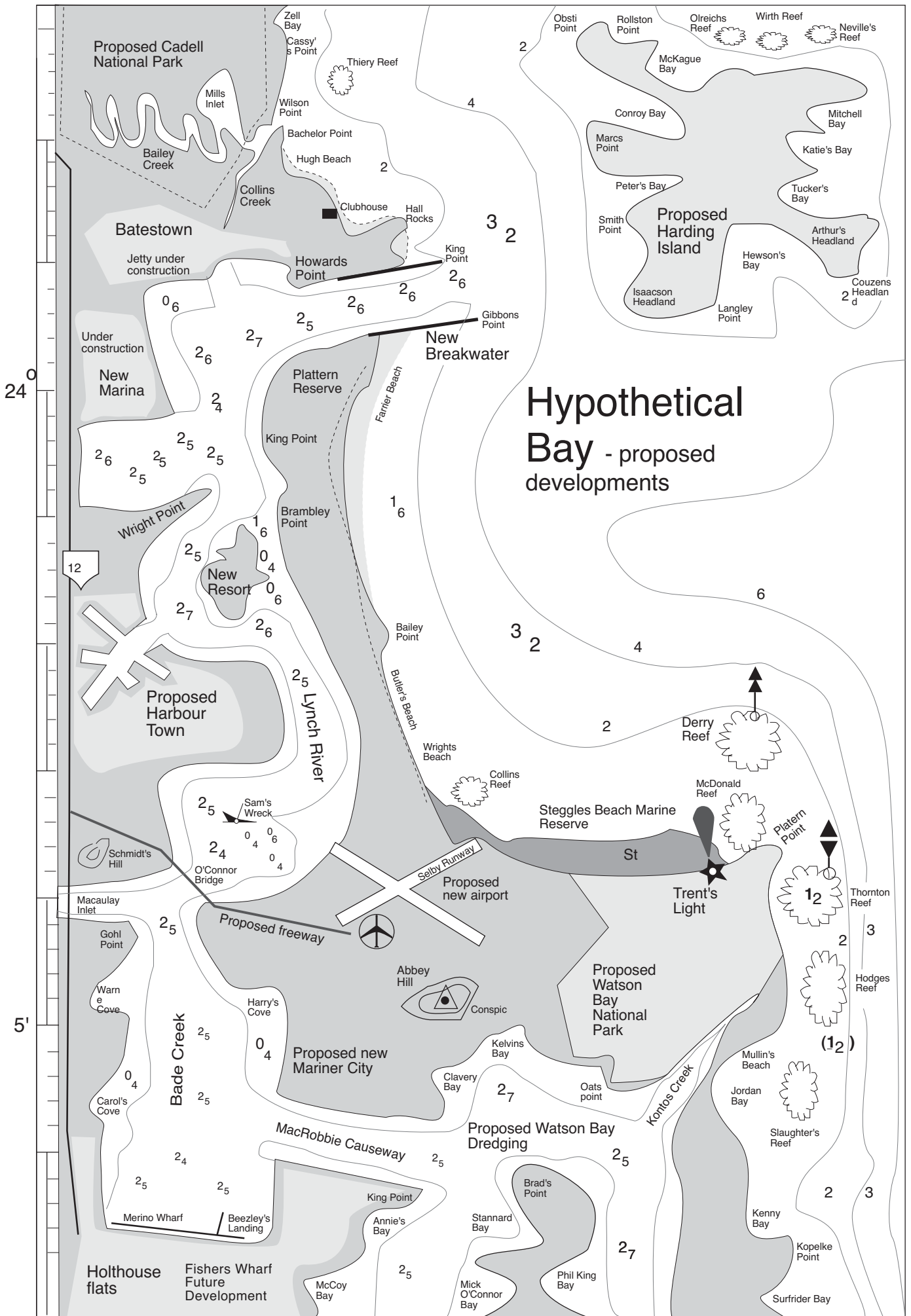
and an exclusive resort opposite Wright Point is planned along the Club Med style.

A secondary sewage system is planned to discharge at King point on the new breakwater, much to the disgust of local environment groups who have taken the council to the environment court and delayed the plans.

The regional government is keen to see the proposals go ahead as they plan to develop a freeway past Schmidts Hill to the new city.

The total cost of the project is 100 billion dollars and is financed by an Arabian consortium of companies. It is the brainchild of a developer living off the coast of southern Europe.

An election is imminent with one party saying it will scrap the entire development while the other is saying it will study the proposals carefully.



- Q4. List any 3 effects an international airport will have on the proposed Watson Bay National Park.
1. *Increased noise may effect the natural fauna*
  2. *The parrots of Smith's National Reserve may be killed by planes or chased from the area*
  3. *Site work may affect fauna*
  4. *Pollution may also be caused*
- Q5. List four effects on the township of Holthouse Flats by the planned Fishers Wharf development.
1. *More tourism*
  2. *Better boat anchorages*
  3. *Maybe more trawlers visiting the area and a fish market may be established*
  4. *More revenue in local economy*
- Q6. Massive ecotourism is set to develop in the Bay. The reefs off Steggles Beach reserve are pristine and need management.
- a. Suggest a zoning plan and state what recreational and commercial activities could occur in that zone.
- Marine Park A zone which allows*
- *No collecting, spearfishing, line fishing and crabbing*
  - *Diving, boating and photography*
  - *No commercial netting*
  - *Camping and research is permitted*
- This zone will allow use of the area but not destruction of the area.*
- If it was zoned - preservation this would not allow any ecotourism in the area.*
- b. Explain how you will go about zoning the reef.
- Elect a Government who would put in place an agency to implement zoning*
- c. What is your vision for the reef 25 years after you draw up these management plans?
- After 25 years of Marine Park A zone I would hope that the reef is in a similar state as it is today. Only Preservation Zoning would guarantee it to remain in a pristine state.*
- Pollution of the adjacent sea may also affect the area.*
- Q7. Explain how the freeway could affect Mariner City.
- The freeway will cause growth of Mariner City.*
- Q8. How do you feel about an exclusive resort being developed in Lynch River? If the resort went ahead, what types of access do you think the general public would have to the resort?
- Water is 'common' property and belongs to everyone. If the resort went ahead I believe the beach and tidal zone should have public access.*
- Q9. Predict if Perry Shoals would suffer from increased use. Will the Bay have to be zoned?
- With the increase in population there will be an increase in boat usage and Perry Shoals will need to be zoned.*
- Q10. Propose any three management plans for Hypothetical Bay 2020.
1. *A population cap be given to the area*
  2. *Increase research on coastal habitats to investigate long term effects of the population increase*
  3. *Establish a better system for setting up coastal reserves*
  4. *Provide advise and expertise to local government authorities so development decisions can be made.*

# Appendices

## Appendix 1 Sample tests 78

1.1	Beaches .....	78
1.2	Seawater and pollution .....	81

## Appendix 2 Field work activities 85

2.1	Can we measure currents in the field? .....	86
2.2	Point break .....	90
2.3	Knots and rope .....	91
2.4	Making a secchi disc .....	92
2.5	Measuring turbidity .....	94
2.6	Make a water sampler bottle .....	96
2.7	Make a field thermometer .....	97
2.8	Photic zone and turbidity .....	98
2.9	Temperature and depth .....	99
2.10	Tides and currents .....	100
2.11	Salinity and pH .....	102
2.12	Dissolved oxygen .....	103
2.13	Making sand sieves .....	104
2.14	Wheelhouse instruments .....	106
2.15	Plankton sample .....	107
2.16	Making a beach walkway .....	108

## Appendix 3 Laboratory work 110

3.1	Weather front demonstration .....	110
3.2	Can we measure seawater density? .....	111
3.3	How do offshore winds occur? .....	115
3.4	Can we recover salt from the sea? .....	118
3.5	Beach formation and erosion processes .....	120
3.6	Wave velocity .....	122
3.7	Wave refraction and sand movement .....	124
3.8	Materials used in boats .....	127
3.9	Orbit fields .....	128

## Appendix 4 Classroom activities 130

4.1	The active beach system .....	130
4.2	Management of longshore drift .....	132
4.3	Model ocean and coastline bathymetry .....	134
4.4	Bay model .....	137
4.5	Delta model .....	138
4.6	Estuary model .....	139
4.7	Offshore island model .....	140
4.8	Headland model .....	141
4.9	Seamount model .....	142
4.10	Practice essay on beach erosion .....	143
4.11	Currents around Australia and New Zealand .....	144
4.12	Forces that cause ocean water to move .....	146
4.13	Ballast water problems .....	148
4.14	Drain stencilling .....	151
4.15	Attitudes and values .....	152
4.16	Sea rights - three level guide .....	154
4.17	Territorial waters and the Australian Fishing Zone .....	156
4.18	Trade waste .....	158
4.19	Adopt an NGO .....	160
4.20	MESA Seaweek and Ocean Care Day .....	162
4.21	Become a reef guardians school .....	163
4.22	Riparian habitat assessment .....	164
4.23	Water velocity in a catchment .....	166
4.24	Sourcing litter pollution .....	168
4.25	Conflicts .....	170
4.26	Dilemma exercise .....	172
4.27	Writing a newspaper article .....	174
4.28	Future problem solving .....	176
4.29	Managers and user groups .....	178
4.30	Management proposals .....	180
4.31	Controversy at Hypothetical Bay? .....	182
4.32	Best environmental practices .....	188
4.33	Problem solving .....	192
4.34	Should Whale Bay have a marine protected area? .....	194
4.35	Images essay .....	207
4.36	Traditional management methods .....	208

## Appendix 5 OHT or worksheet illustrations 210

5.1	Seas and oceans .....	210
5.2	Ocean formation .....	211
5.3	Ocean depth and topography .....	212
5.4	Australia topography .....	213
5.5	World currents .....	214
5.6	Coastline summary .....	215
5.7	Ice age sand movements .....	216
5.8	Hypothetical Bay .....	217
5.9	Hypothetical Bay development .....	218
5.10	Sand dune profile .....	219
5.11	Sand dune systems .....	220
5.12	Beach nourishment methods .....	221
5.13	Boulder walls .....	223
5.14	Beach erosion and housing development .....	224
5.15	Sand bypassing system .....	225
5.16	Seawater and light .....	226
5.17	Seawater and pH .....	227
5.18	Web page password and activities .....	228

# Appendix 1 Sample tests

## 1.1 Beaches

**Time 50 minutes**

Use your textbook to answer the following questions:

### Part A: Knowledge and understanding

- A low lying ridge of sand or pebbles joined to the land at one end and terminating at the other in deeper waters is called a:
  - bar
  - spit
  - tombolo
  - coorong
- The solid mounds found in Shark Bay, Western Australia which are formed by the microbial action of cyano-bacteria trapping sediments are called;
  - tombolos
  - stromatolites
  - rock corals
  - sea stacks

The next question refers to the information in the table below

Class	Subclass	Equivalent Diameter	Average slope of beach in degrees
Boulder		250 mm or more	> 25 degrees
Gravel	Cobble	65-250 mm	10 - 25 degrees
	Pebble	5 - 65 mm	
	Granule	2 - 5 mm	
Sand	Very course	1 - 2 mm	5 - 9 degrees
	Course	.5 - 1 mm	
	Medium	.25 - .5 mm	
Mud	Very course	.07 - .25 mm	< 5 degrees
	Course	.002 - .07 mm	
	Medium	less than .002 mm	

- Which of the following statements are true:
  - beach slope increases where wave action increases.
  - beaches which have high energy waves will have fine sand and a slope of < 5 degrees.
  - muddy beaches will have a steep slope.
  - muddy beaches will have sand grains of 1 - 0.5mm.
- The distance over which the wind can actually manufacture waves is called:
  - orbit fields
  - the fetch
  - shoaling
  - reflection
- The speed of a wave in a certain direction that can be expressed in metres per second is:
  - celerity
  - wave frequency
  - orbit fields
  - airy waves

**Note: These are a basis of ideas and will have to be rewritten if your school is following national literacy standard guidelines.**

Answers

- |      |      |      |      |
|------|------|------|------|
| 1. b | 4. b | 7. a | 10.b |
| 2. b | 5. a | 8. c | 11.d |
| 3. a | 6. c | 9. d | 12.b |
|      |      |      | 13.a |

- A wave approaching the South East coast of Australia has a length of 25 metres and a height of 2 metres over a period of four seconds. The celerity of the wave will be:
  - 100 metres/second
  - 0.5 metres/second
  - 6.25 metres/second
  - 8 metres/second
- When a wave bends as a result of shallow waters around a point, refraction is said to occur. A right angle drawn to the crest is called an:
  - orthogonal
  - reflected wave
  - adjacent
  - ryanogon
- The ASLA has identified four types of rips. A rip that occurs where a depression suddenly occurs in a beach profile is termed q:
  - travelling rip
  - fixed rip
  - flash rip
  - permanent rip
- Which of the following statements about microridges is FALSE:
  - microridges mostly contain a variety of sand grain sizes
  - the size of the microridge is dependant on the energy of the wave bore
  - microridges are minute ridges on a beach containing sand dropped when the wave bore stalls
  - microridges are minute ridges of sand framed on a beach that can be studied microscopically to show lateral sand movement
- The maximum distance the wave bore travels up the beach is called the \_\_\_\_\_. The wave bore is the broken part of the original wave as it runs up the beach. The missing word is:
  - beach berm
  - swash zone
  - accreting zone
  - shoaling zone
- Which of the following is NOT a sign of erosion:
  - no microridges are visible.
  - sand is hard in the swash zone.
  - black heavy minerals washed to the head of the beach.
  - distance between wave bore decreasing.

12. Dune vegetation plays an important role in the formation and stabilization of coastal sand dunes. Which of the following statements concerning dune vegetation is FALSE:
- prevents wind erosion by decreasing wind speed at ground level.
  - prevents direct wave erosion by strongly binding the sand with roots.
  - dune vegetation can tolerate a hostile environment — high winds, salt spray, little water.
  - the sand provides a stimulus for the plants to grow and the dune will increase in size.
13. Fretting is:
- when the dunes are eroded, and the roots of the plants and shrubs are left dangling on the erosion scarp.
  - the formation of pioneer vegetation on the erosion scarp.
  - the washing away of the primary dune in storm surges.
  - the formation of offshore beaches called storm bars.

**Part B: Information processing and reasoning**

1. This question refers to the graphs in Figure 79.1.

The Beach Protection Authority believes "The control of windblown sand and retention of vegetated and naturally stable coastal sand dunes are a valuable means of decreasing coastal erosion and because of this the Authority implements a broad research program into the management of coastal sand dunes".

The graphs in Figure 79.1 show the effect of fertilizers especially nitrogen, in the growth of horsetail she-oak trees.

a. Compare the growth rates of sea oaks with different amounts of fertilizer between the years 1999/2000. Distinguish between recorded heights.

*Complete fertilizer gave the highest growth rates 130 cm compared to no fertilizer 78-80 cm and fertilizer minus nitrogen 55-58 cm*

b. Explain the fact that fertiliser minus nitrogen had a negative effect on growth rate?

*Nitrogen is necessary for plant growth*

c. Compare the effect of treatment on the canopy covers of horsetail she oaks with coastal wattles

*Complete fertilizer increases she oaks canopy cover greater than coastal wattle.*

d. Argue a case for planting she oaks in front of coastal wattles in a beach protection scheme based on the principle of nitrogen fixation

*She oaks could be better at fixing nitrogen and so planting them first may protect the coastal wattle*

*or students own answer*

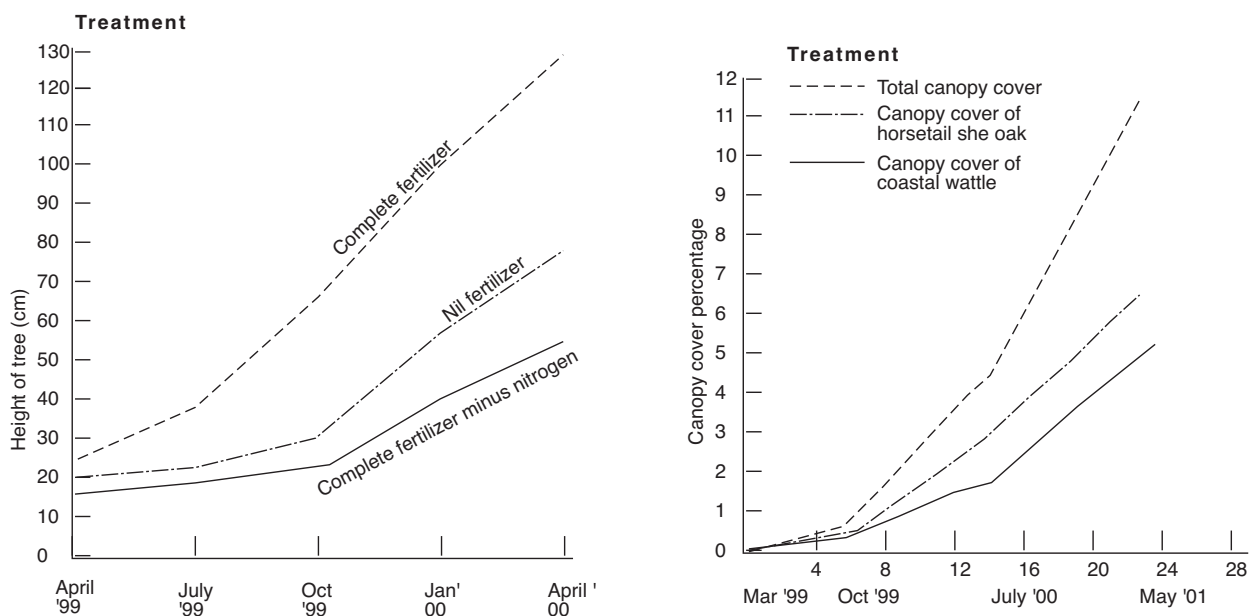


Figure 79.1 Data from beach protection agency

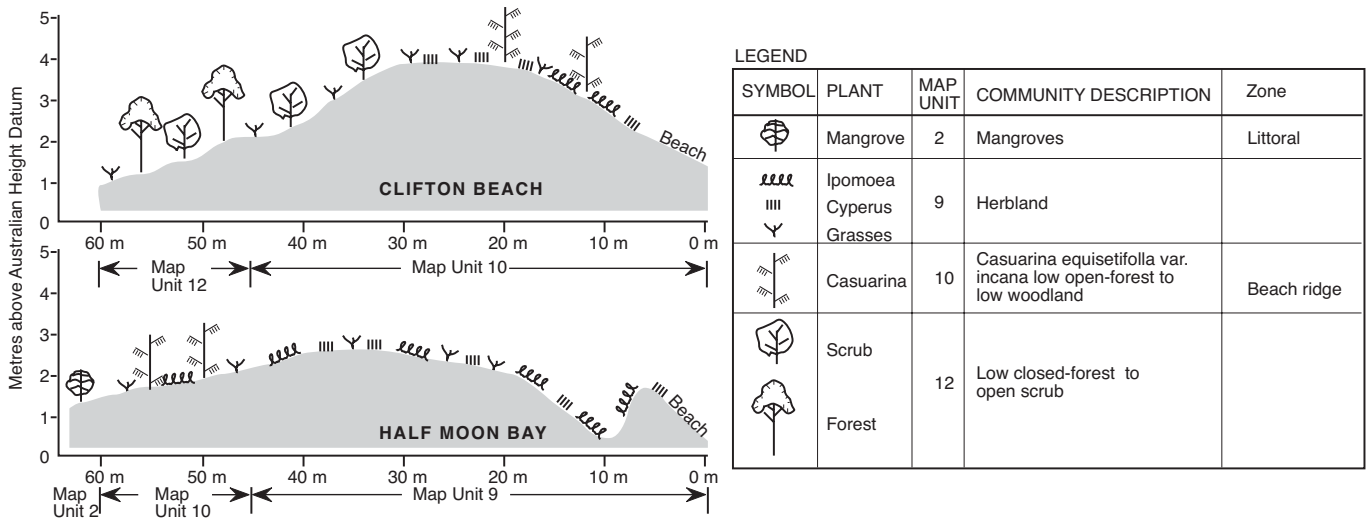


Figure 80.1 Comparison of Clifton Beach and Half Moon bay dune profile data

2. Half Moon Bay and Clifton beach are located north of Cairns in Queensland. Vegetation transects recorded at Clifton Beach and Half Moon Bay are shown in Figure 80.1

a. Tabulate two similarities and two differences between the two vegetation transects.

<i>Similarities</i>	<i>Differences</i>	
<i>Half Moon Bay/Clifton Beach</i>	<i>Half Moon Bay</i>	<i>Clifton Beach</i>
<i>Casuarinas present</i>	<i>Mangroves</i>	<i>No mangroves</i>
<i>Ipomoea sp present</i>	<i>No shrubs</i>	<i>Shrubs</i>
<i>Grasses present</i>	<i>No forest</i>	<i>Forest</i>
<i>Ipomoea present</i>		

b. Explain which beach has vegetation that would be considered to be climax vegetation.

*Clifton Beach has a forest indicating some type of organised community*

c. Explain which beach is more likely to have some protection from the sea.

*Clifton Beach has a higher dune system*

d. Distinguish between the vegetation, zones and community descriptions found in Map Units 2, 9 and 12. Which map unit is most likely to be behind the dunal system?

*Map unit 2 has mangroves found in the littoral zone*

*Map unit 9 herbland with grasses, ipomoea and Cyperus - no zone is indicated*

*Map unit 12 is in a low closed forest to open scrub land behind the dunal system*

e. Compare the distribution of casuarinas at the two beaches.

*Casurinas are located closer to the waters edge at Clifton Beach*

f. Predict two likely consequences to the dunal system at Clifton Beach if the casuarinas were bulldozed for a new resort development.

*Dune heights would decrease creating possible beach erosion in storms*

*The forest area would disappear because increased salt air could kill the trees*



## 1.2 Seawater and pollution

Use your textbook to answer the following questions. Circle the correct response.

### Knowledge and understanding

- Which of the following statements about salt are FALSE:
  - Salt contains the elements of sodium and chlorine.
  - Salt is an inorganic material.
  - Salt crystals are a combination of salt molecules held by ionic bonds.
  - The salt in sea water is made up of only sodium and chloride elements.
- Which of the following statements are TRUE:
  - Organic matter is more likely to dissolve in water than inorganic material.
  - Environments with high levels of dissolved oxygen are usually able to sustain a low species diversity.
  - Water becomes more acidic as the pH increases.
  - The amount of phosphorus in water can be reduced by reducing the amount of fertilizer.
- If a salt solution being made up in class had 5 grams of salt added to 200 millilitres of water, then the concentration of the solution produced in ppm would be:
  - 5000 ppm
  - 40 ppm
  - 50000 ppm
  - 25000 ppm
- If a group of students is required to make up 200 millilitres of a 35g/L salt solution (35000 ppm), how much salt would need to be added to the 200 millilitres of water?
  - 70 grams
  - 7 grams
  - 3.5 grams
  - 1000 ppm
- Using the calibration graph shown in Figure 81.1, how many drops of silver nitrate would indicate a salinity of 25 g/litre:
  - 15 drops
  - 20 drops
  - 25 drops
  - 30 drops
- The major gases that dissolve in sea water are nitrogen, oxygen and carbon dioxide. The amount of gases that dissolve depend on three factors. Which of the following is NOT one of those factors:
  - Temperature of the sea water
  - Depth of the water
  - Salinity of the water
  - BOD of the water
- True or false?  
The colour of seawater is caused by the scattering and absorption of light by the water

### Answers

- |      |         |      |      |
|------|---------|------|------|
| 1. d | 5. c    | 9. a | 13.b |
| 2. d | 6. d    | 10.a | 14.b |
| 3. d | 7. True | 11.c | 15.c |
| 4. b | 8. b    | 12.a | 16.d |

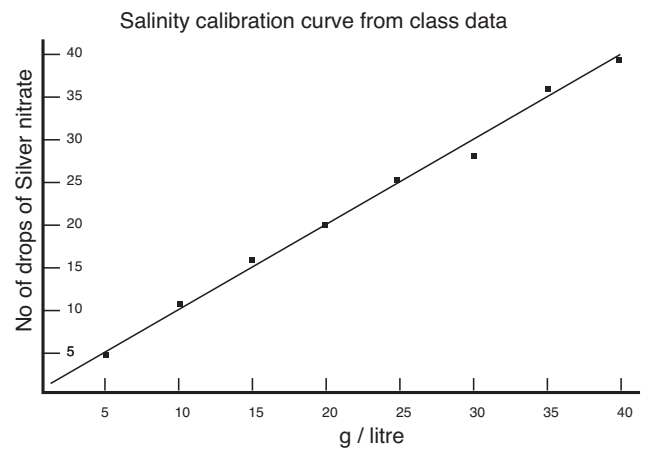


Figure 81.1

- Which of the following organisms had the greatest tolerance to pH in Figure 81.2?
  - Shellfish and clams
  - Bacteria
  - Algae
  - Fish

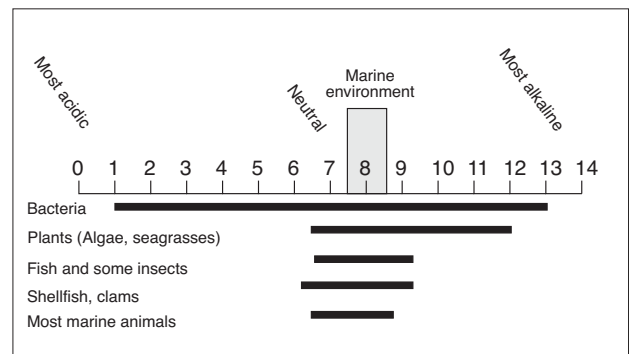


Figure 81.2

- Which of the following organisms would most likely survive in alkaline waters in Figure 81.2?
  - Sea grasses
  - Fish
  - Clams
  - Most marine animals
- The BOD test measures the:
  - amount of organic material in water
  - amount of oxygen dissolved in the water
  - amount of phosphates in the water
  - Q factor of the water

11. The measurement of temperature is the difference from one point to another so you have to select two regions of the river or estuary. The thermometer is lowered to a depth of 200 mm and the temperature is recorded. Another reading is taken one kilometre upstream using the same method and the same thermometer.

If the temperature at point A is 16 degrees centigrade and 1 kilometre upstream the temperature is 21 degrees centigrade. Use the table in Figure 82.1 to calculate the Q value. The Q value would be:

- 50
- 65
- 75
- 85

12. Cultural eutrophication is:

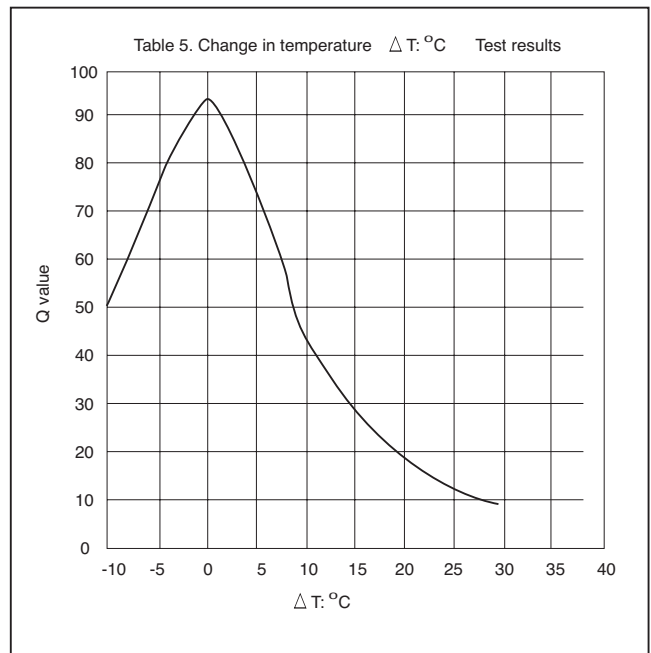
- an enrichment of the water, usually by phosphorus and human pollution.
- an enrichment of the water by natural means causing plant blooms.
- a build up of organic matter in water causing aerobic conditions.
- a build up of phosphates in the coastal sand dunes.

13. Denitrifying bacteria:

- are bacteria which convert the atmospheric nitrogen into nitrates.
- are bacteria which convert nitrates into nitrogen which releases back into the atmosphere.
- convert plant material into nitrates which are released into the water.
- are found in the root nodules of She-Oaks.

14. The turbidity of the water is measured by:

- using a pH meter.
- using a secchi disc.
- collecting a sample of water and boiling off all the water and weighing the residue.
- using a solution of silver nitrate.



After Mitchell and Stapp (1988) Page 70. Reproduced with permission.

Figure 82.1

15. High levels of turbidity cause all but one of the following consequences:

- less diversity of Aquatic organisms
- water becomes warmer as suspended particles absorb heat from the sun
- water becomes oxygen enriched
- reduction of photosynthesis

16. High concentrations of total solid leads to all but one of the following:

- reduction in nitrate and phosphate levels
- a decrease in water clarity
- a decrease in the number of filter feeder living on the sea floor
- an increase in the amount of phytoplankton activity

Estuary Description	Name of Estuary	Lower Estuary			Middle Estuary			Upper Estuary			
Unpolluted estuaries	Mooloolah Burrum	0.414	-	-	0.440	0.574	-	0.719	0.646	-	-
		0.567	-	-	0.546	0.645	-	0.756	0.763	0.770	-
Nutrient enriched estuaries	Burnett	0.549	-	-	0.684	0.888	-	1.178	1.118	1.051	-
	Hays Inlet	0.848	0.864	-	1.136	-	-	1.270	-	-	-
	North Pine	0.568	-	-	0.972	1.630	-	1.445	-	-	-
	Caboollture	-	-	-	0.766	0.882	1.154	1.344	1.745	2.347	1.840
Nutrient enriched estuaries with significantly light limited reaches	Logan 80/81	0.590	0.935	-	1.073	1.443	1.884	2.110	1.986	-	-
	Logan 83/84	0.590	0.985	-	1.280	1.714	1.796	1.600	-	0.800	-
	Albert	1.141	1.237	-	1.212	1.093	-	0.836	0.577	-	-
	Mary	0.408	0.567	-	0.998	1.197	1.132	0.907	0.698	0.684	-
	Brisbane Fitzroy	0.833	0.932	1.408	1.771	2.177	1.944	1.793	1.546	0.726	-
		-	-	-	0.978	1.179	-	1.457	1.695	1.383	-
Small creek	Petrie Creek	0.805	-	-	1.903	-	-	3.295	5.418	6.920	-

Figure 82.1 Mean total nitrogen levels (mg/l N) in some Queensland estuaries. (data supplied courtesy Dept. of Primary Industries)

**Part B: Information processing and reasoning**

1. From the table of data in Figure 86.1, answer the following questions:

a. Which estuaries are regarded as unpolluted and which are nitrogen enriched?

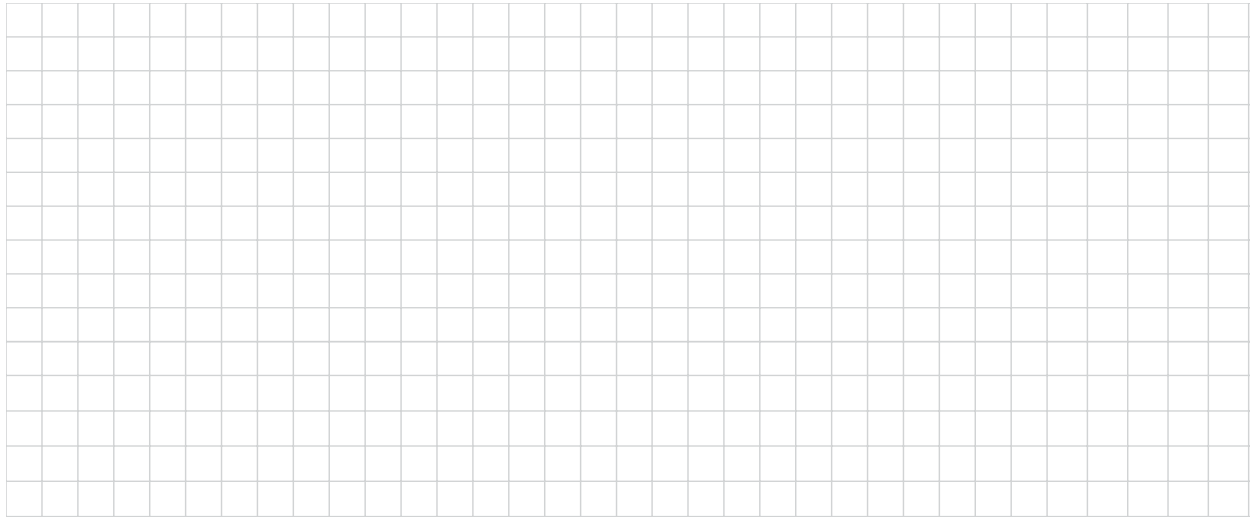
*Mooloolah and Burrum (unpolluted) Burnett, Hays Inlet, North Pine, Caboolture*

*Logan, Albert, Mary, Brisbane and Fitzroy*

b. Which river had the highest level of nitrogen (mg/l) and what was this value?

*Logan 2.11 mg/L (Petrie is a Creek 6.9 g/L)*

c. Graph the value for the Logan River for the period of 1980/81 and 1983/4. How have the values changed? Propose a suggestion to explain these values.



*Students own answers*

d. Attempt to explain the reason why the nitrogen levels are generally higher in the upper estuaries than the lower estuaries.

*Agricultural run off*

e. Where may the sewage be entering Petrie Creek? Explain.

*Higher level of nitrogen 60%*

f. Suggest other nutrients which may have shown similar trends to the nitrogen in the table above.

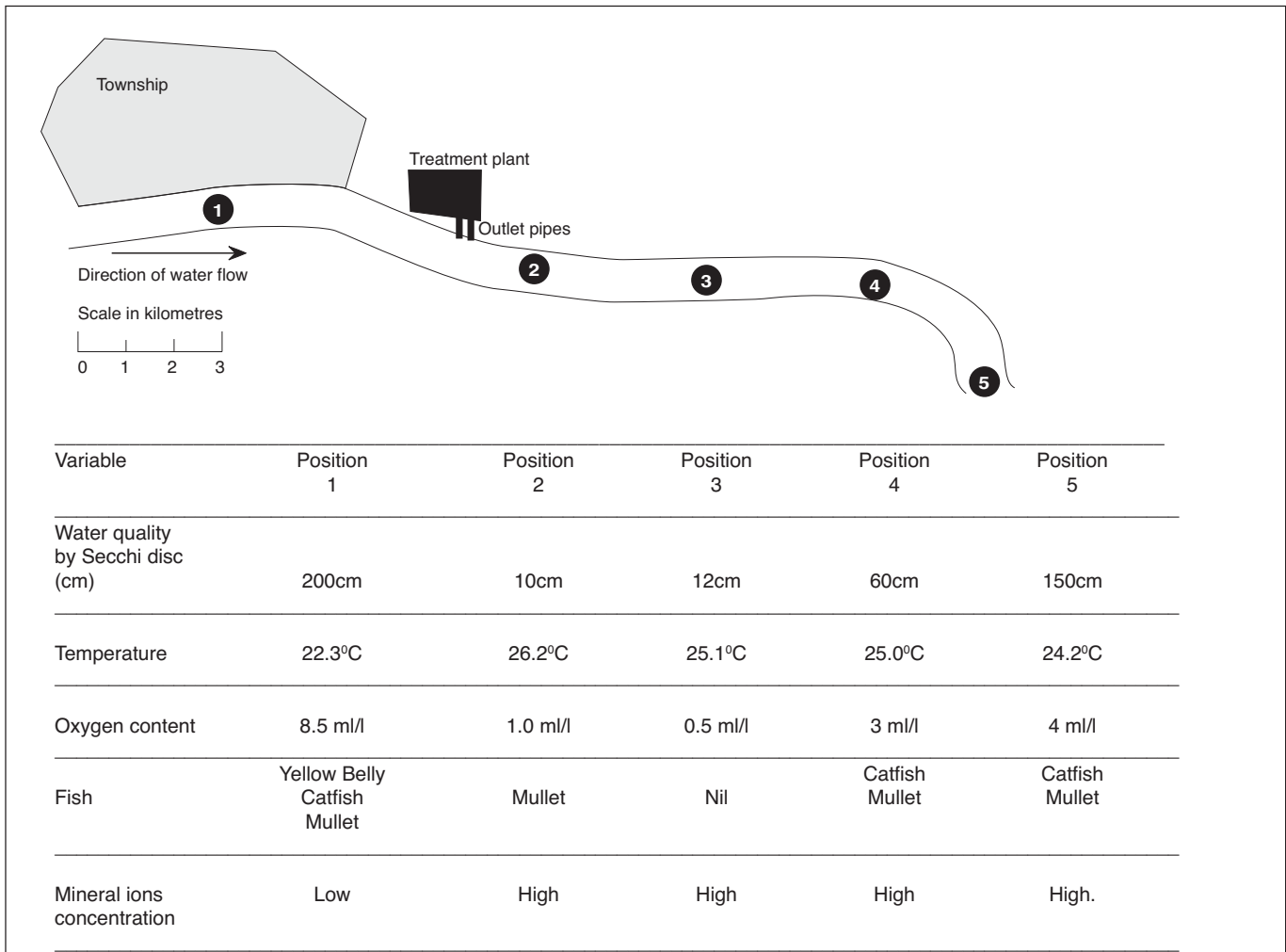
*Phosphorus, heavy metals*

2. Muswellbrook, Singleton, Maitland and Newcastle are towns situated on the Hunter River system of NSW. The towns are approximately 50 kilometres apart on the Hunter River and use the water for domestic, agricultural and industrial purposes.

What problems may be caused by having all four towns on the same river? Will it make the detection of the source of pollutants harder to track down?

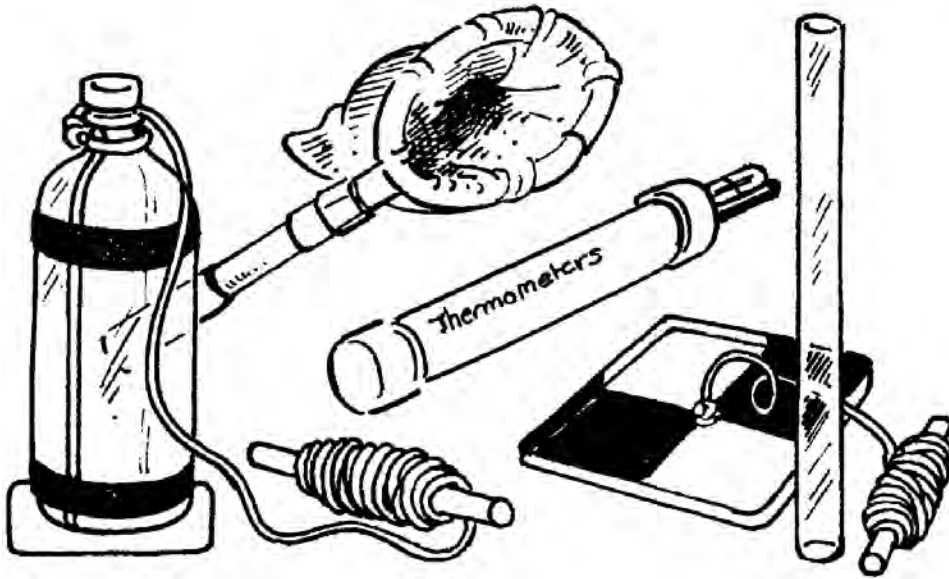
*Point source pollution may be a problem due to confusion in sources*

*Stormwater and sewerage effluent*



3. Refer to the figure above:
- Organisms which can only live in special environmental conditions are said to be indicator species. These organisms have a low tolerance range. Which of these species is an *indicator species*?
    - catfish
    - mullet (Answer)
    - yellow belly
  - Why will the oxygen concentration decrease as you progress from position 1 to position 5?  
*Nutrients use up the oxygen in the water as part of respiration*
  - Discuss the water clarity, based on secchi disc readings, from position 1 to 5. What may have happened between position 1 and 2?  
*Sewerage seems to have an effect on water turbidity. Stormwater from Township or dredging of the river may have lead to increased turbidity*
  - What effect might the increase in mineral ion concentration have on the aquatic life from positions 3 to 5?  
*Increases algal growth, fish mortality*
4. Distinguish between the terms *point source* and *non-point source pollution* in the figure above giving an example of each
- A point source of pollution is a single identifiable localized source eg sewerage outlet pipe.*
- Nonpoint source (NPS) pollution is water pollution affecting a water body from diffuse sources, rather than a point source which discharges to a water body at a single location.*
- Water runoff from the land or air pollution blowing around the streets of the town.*

# Appendix 2 Field work activities



## 2.1 Can we measure currents in the field?

### *Aim*

- To measure currents on a beach or in a river.

### *What to do*

- Read page 72 of your textbook and answer the questions below.

### *Questions*

Q1. List items used to make simple field measuring equipment.

---

---

---

Q2. Describe how you could measure current in a river or estuary.

---

---

---

---

---

---

---

---

---

---

---

---

---

---

---

---

---

---

---

---

---

---

---

---

Q3. Complete Table 1 opposite for river/estuary data and map of your study area.

---

Q4. Describe how you could measure current on an open beach.

---

---

---

---

---

---

---

---

---

---

---

---

---

---

---

---

---

---

---

---

---

---

---

---

Q5. Complete Table 2 opposite for beach data and map of your study area.

---

Q6. Describe any other method you could use on the beach or in an estuary.

---

---

---

**Table 1: River or estuary results**

Description of what happened

Data and calculations

---

---

---

---

---

**Questions**

Q1. Estimate the speed of the current.

---

Q2. Identify the current direction.

---

Q3. Explain what caused this current.

---

Q4. Decide if these currents will change during the day and if so propose an explanation.

---

---

**Map of study area**

Show direction of current flow and main features

**Table 2: Beach results**

**Questions**

Q1. Identify the current direction.

---

Q2. Which orange travelled faster - inshore or far out? Propose a reason for this.

---

---

**Map of study area**

Show north and main features of beach

## Activity 2.1 - suggested answers

### Questions

Q1. List equipment used to make simple field measuring equipment.

*Electrical tape, empty plastic bottle, old broom stick, drill, divers weight 11 metres venetian blind cord, coloured materials (for flag), watch with second hand*

Q2. Describe how you could measure current in a river or estuary.

*Make a map of the area.*

*Now tie 10 metres of cord to a drink bottle.*

*Select a place such as a jetty where the current is running and you can launch your drogue.*

*Lower the drogue into the water and tell your partner to time how long it takes for the drogue to run out to the full length of the 10 metres of rope on a prearranged signal.*

*When a partner is ready, release the drogue and observe what happens.*

*Use the hand bearing compass to determine the direction of the current.*

*Using the formula*

*Speed = distance / time*

*calculate the speed of the current and record it. Repeat the experiment twice and average your results.*

Q3. Complete Table 1 opposite for river/estuary data and map of your study area.

*See table and map opposite*

Q4. Describe how you could measure current on an open beach.

*Pace out 5 stations, 15 metres apart on the beach.*

*At a prearranged signal you cast two oranges into the sea*

*- one close in the other as far out as you can throw and the timekeeper starts the watch.*

*Then follow the two oranges and any variations. If the orange comes in, you should throw it out again.*

*After one minute the timekeeper signals and marks the position of your orange in the sand opposite where the orange is.*

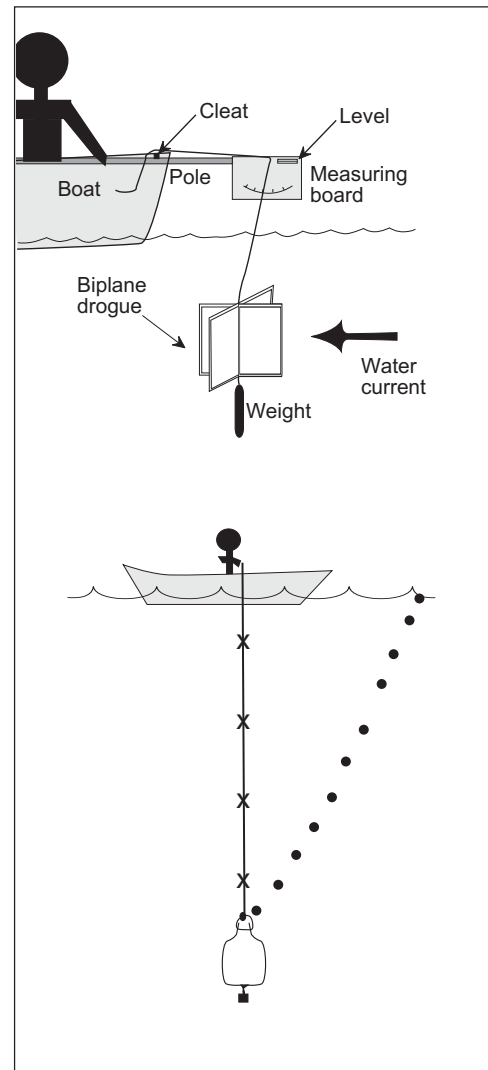
*After two, three, four and five minutes, record data accurately*

Q5. Complete Table 2 opposite for beach data and map of your study area.

*See table and map opposite*

Q6. Describe any other method you could use on the beach or in an estuary.

*Students own answers*





## Activity 2.1 - suggested answers

**Table 1: River or estuary results**

Description of what happened

Data and calculations

*Length of rope*

*Time to run length out*

*Speed of current*

*(Distance/time)*

*Direction of current*

**Questions**

1. How fast was your current?

*Students own answers*

2. In what direction did it go?

*Students own answers*

3. What causes currents?

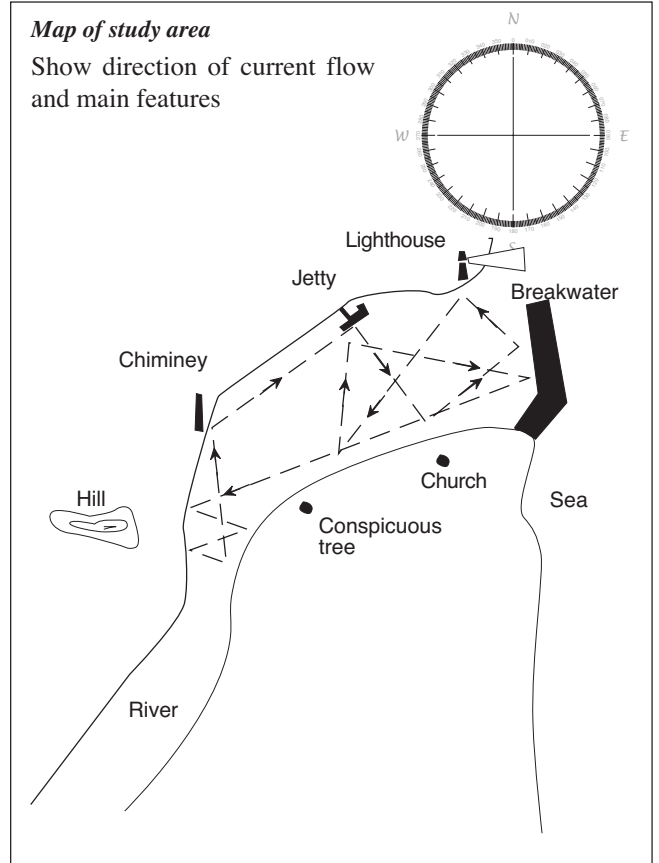
*Students own answers*

4. Do you think currents will change during the day and if so what could cause these changes?

*Tides, low pressure systems*

**Map of study area**

Show direction of current flow and main features



**Table 2: Beach results**

**Questions**

1. Which direction did the current flow?

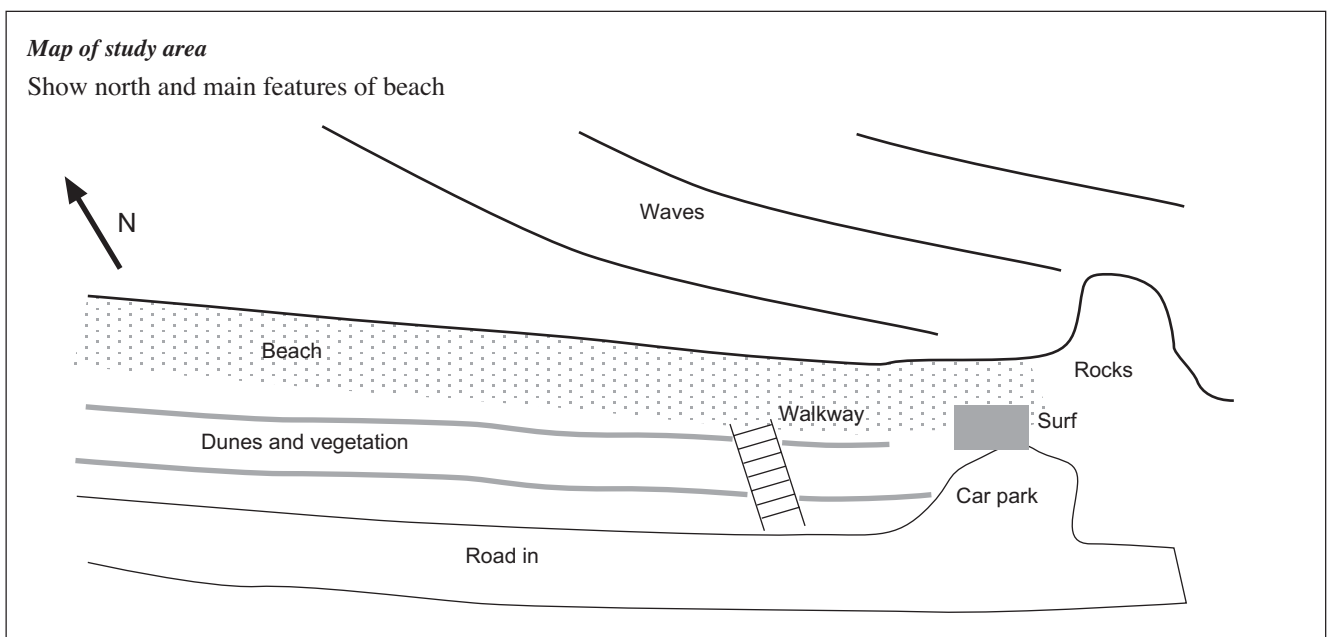
*Students own answers*

2. Which orange travelled faster - inshore or far out?

*Students own answers the ones in closest should travel faster*

**Map of study area**

Show north and main features of beach



## 2.2 Point break

### Method

1. Arrange an excursion to your local beach and find a cliff, headland or raised dune area like the one shown in Figure 90.1, so that you can overlook the waves as they travel towards the beach.
2. Complete the worksheet in Figure 90.2.
3. Make a sketch of the headland system as if you were looking down from an aeroplane.

Now mark the direction in which the waves are travelling. Add the position of the rocks and where the sand begins.

Note also the areas where waves break and where sand accumulates.

4. Find out and record the difference between wave refraction and wave diffraction?

### Questions

To be completed while studying the waves.

- Q1. Can you tell where the water is flowing the fastest? Mark this on your drawing. What evidence do you have for this? How do surfers get out to the break point? Is there any special pattern to their surfing?
- Q2. Why do the waves slow down as they near the rocks?
- Q3. Does the tide make any difference to the size and breaking pattern of the surf at the point?
- Q4. Find a local lifeguard or surfer and ask them if the rip at the point is the greatest at full tide, half tide or low tide. Ask the local to give a reason for the answer.
- Q5. Look carefully at the waves as they break. Make a note of where sandbanks are.
- Q6. Make a list of the materials that make up the headland. Is there any evidence that the headland is eroding?



Figure 90.1 Local headland

- Q7. What is the time between waves? Calculate the speed at which the waves are travelling and try to determine the distance between wave crests.
- Q8. How many waves are passing a fixed point in 10 seconds?
- Q9. Why do surfers avoid certain waves?
- Q10. Is there any reflection of waves as they strike the headland or refraction as they pass the point? If so, where does this occur?
- Q11. There are three main types of waves: spilling, plunging and surging. Observe all the waves that break on or around the headland and record which types occur where. Do the same on a beach.
- Q12. Do all waves have the same colour? Record the colours you see and suggest reasons for the colour changes.

### Materials required

- pencil and worksheet
- compass or local knowledge of wind directions
- a partner
- digital camera (optional)

### Wave watchers worksheet - beach

#### Sea conditions:

Date: .....	Wind speed .....	Water clarity in surf zone	<input type="checkbox"/> murky
Time: .....	Water temperature .....	Tide (ebb or flood) .....	<input type="checkbox"/> clean
Taste of surf .....			
Smell of surf .....		Wave height	<input type="checkbox"/> 0 - 0.5 m
Wave colour .....		(max over	<input type="checkbox"/> .5 - 1.0 m
Wave sound .....		5 mins)	<input type="checkbox"/> 1 - 1.5 m
			<input type="checkbox"/> 1.5 - 2.0 m
			<input type="checkbox"/> 2.0 - 2.5 m
Wave Shape	<input type="checkbox"/> smooth	Wind direction	<input type="checkbox"/> on shore
	<input type="checkbox"/> choppy		<input type="checkbox"/> off shore
	<input type="checkbox"/> broken white caps		<input type="checkbox"/> nil
	<input type="checkbox"/> clean lines approaching the shore		
	<input type="checkbox"/> other .....		

### Sample worksheet

Figure 90.2 Sample worksheet

## 2.3 Knots and rope

### Method

The bowline, definitely the most useful knot of all, is used to form a temporary loop in the end of a rope and may be used where a line is required to be secured through or around something.

1. Research the terms *bitter end*, *standing part* and *bight*.
2. Now follow the instructions below.
  - Make a loop in the rope end (sometimes called a *rabbit hole*),
  - Pass the free end up through the loop (sometimes called *up the rabbit hole*).
  - Then pass the free end around the rope end (or *around the tree*)
  - Bring the rope back through the loop (*back through the rabbit hole*).
  - Pull the knot tight.

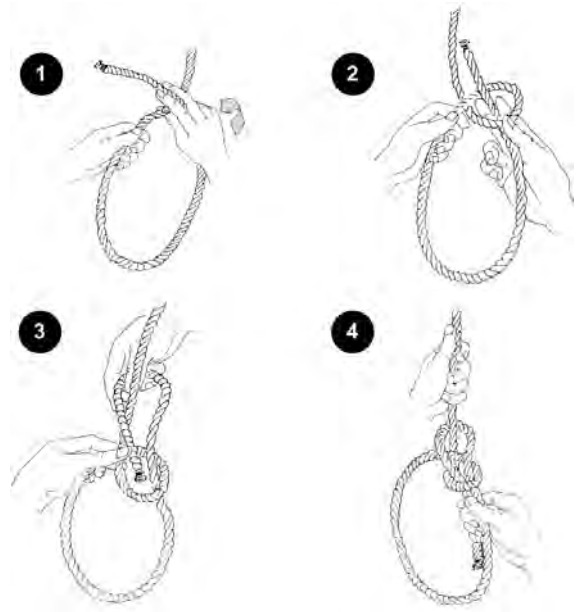


Figure 91.1 How to tie a bowline

### Basic ropework

Use of rope is essential if lab equipment is to work efficiently. Knots are essential to ensure lab gear does not get lost.

#### Storage

The best method of storage is, after removing any knots, to coil the rope and hang it in a light airy place away from any heat and not in direct sunlight.

#### Tying knots

There are plenty of web sites today to show you how to splice rope and tie knots

For example

[www.animatedknots.com](http://www.animatedknots.com) or just google - how to tie knots

Figure 91.2 shows some rope skills and references to knots mentioned in this workbook.

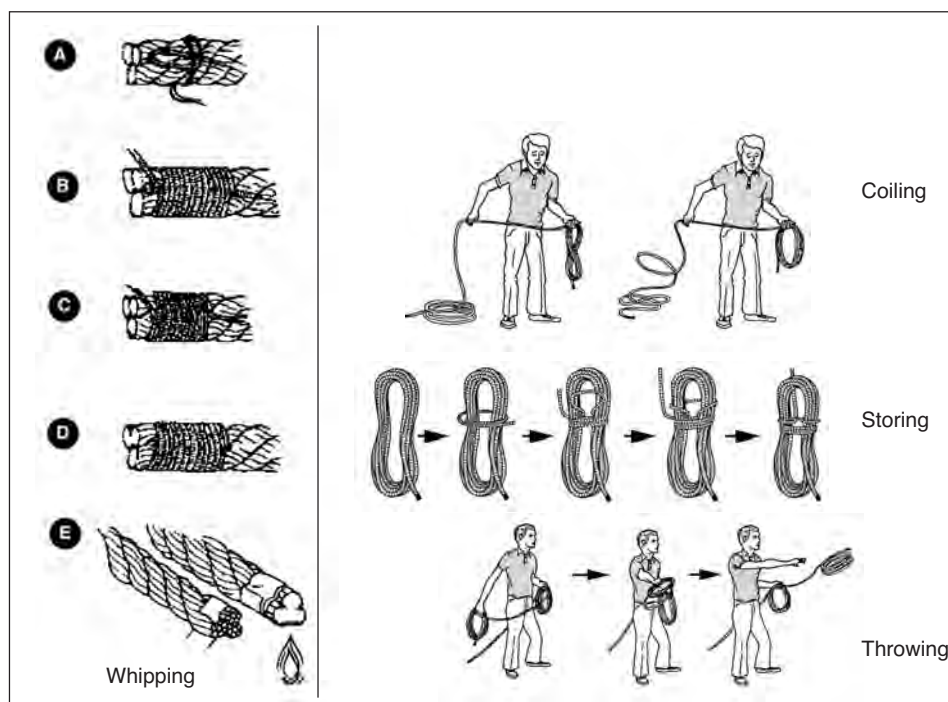


Figure 91.2 Common whipping and rope skills

## 2.4 Making a secchi disc

by Mick O'Connor, Ballina SHS

### Materials

- 20 litre plastic paint drum lid
- Black permanent marker pen
- Cup hook
- Lead weight
- Plastic tape measure
- Drill and suitable bit

### Background

Turbidity is a measure of clarity in a fluid caused by the presence of suspended matter. At high turbidity levels :

- Water loses its ability to support a diversity of aquatic organisms.
- Light penetration is low.
- Waters become warmer as suspended particles absorb heat from the sun.
- Warmer water reduces the amount of dissolved oxygen which can affect fish and plant populations.
- Less light can penetrate water depths which affects photosynthesis.
- The suspended particles can sink and cover fish eggs or burrows of crabs and prawns in the larval or sub adult stages.
- In areas where coral reefs are close to land, sediment can affect the corals causing death and subsequent loss of habitats for reef creatures.

A Secchi, or visibility disc is used to measure the transparency of the water column. The disc consists of a quartered 20cm diameter white and black disc which is lowered into the water until the distinction between the disc quadrants is no longer visible. The depth is measured in centimetres and gives the 'visibility distance'. It is a convenient absolute measurement and allows comparison between water columns.

### Method

- Step 1 Using a compass mark out a 20cm diameter circle on the lid. On many lids one of the moulding marks is the correct size or so close to it that it can be followed.
- Step 2 Carefully cut the circle out with a pair of tin snips.
- Step 3 Divide the circle into four quarters.
- Step 4 Using the black permanent marker colour in two opposing quarters black as shown.
- Step 5 Place the lead weight on the underside. Glue it in the centre of the disc with silicon.
- Step 6 Using a suitable drill and drill bit, drill a hole through the centre of the disc into the lead.
- Step 7 Screw the cuphook into this hole.
- Step 8 Attach the tape to the cuphook.



Figure 92.1 Screwing the cup hook in through the disk into the lead weights,

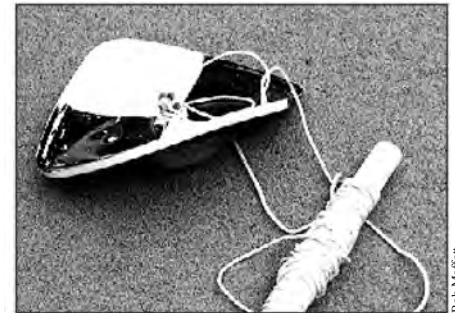


Figure 92.2 Inexpensive type of secchi disk using a brick and a ice cream container lid.



Figure 93.1 Materials

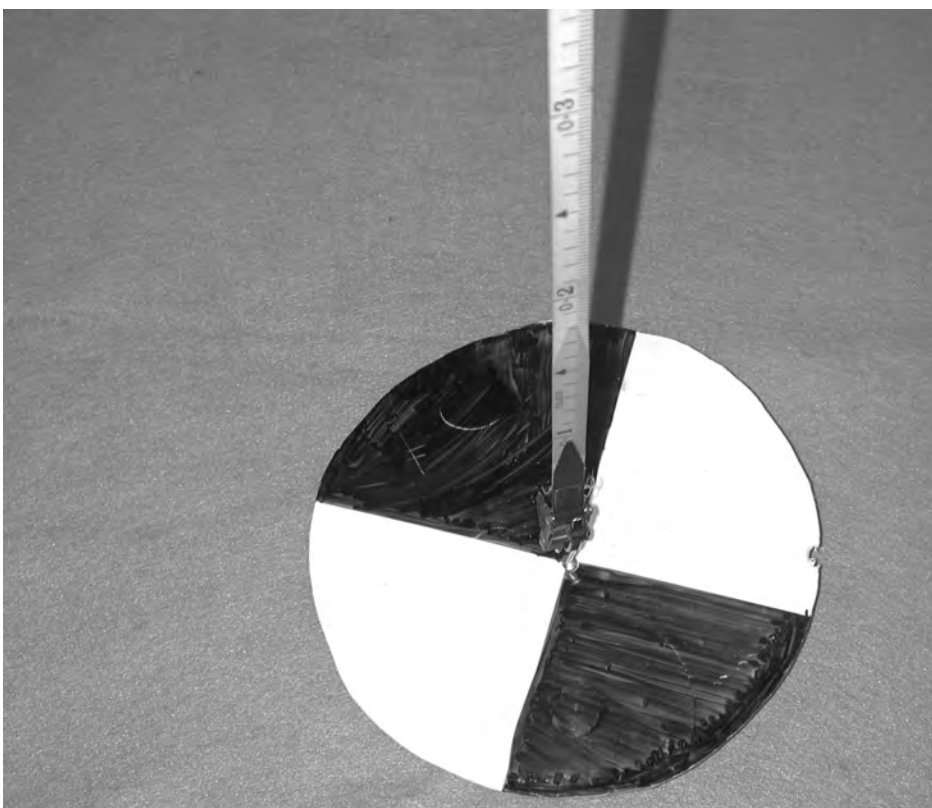


Figure 93.2 Finished secchi disk

## 2.5 Measuring turbidity

by Mick O'Connor, Ballina SHS

'Murkiness' is the first and most obvious feature people notice about any body of water. Clear water is seen as a 'good' feature while muddiness is seen as 'bad'. To avoid confusion we should be aware of the terms:

- Turbidity is the measure of the light scattering properties of water. The light is scattered by suspended (held up) matter in the water and so turbidity depends on the amount, size and composition of this suspended matter - things like clay, silt, organic matter, plankton and other microscopic organisms. Turbidity is measured with a turbidity tube in nephelometric turbidity units (NTU).
- Suspended solids refers to the mass of undissolved solids suspended in the water. Suspended solids are filtered, dried and weighed and recorded as milligrams of solids per litre of water (mg/L).
- Clarity is a measure of how clear or transparent the water is. Clarity is measured using a Secchi disc and is recorded as centimetres (cm). It depends on both colour and light scattering and is usually referred to as visibility by snorkellers and SCUBA divers.

You must decide on which one you will measure and that will depend upon the aquatic environment you are studying.

For riverine systems, turbidity or suspended solids are the most appropriate features to measure. For wetlands, estuaries and marine systems: clarity, measured using a Secchi disk, is the most appropriate feature to measure.

In this case we are measuring turbidity. High turbidity does not make water 'look good'.

The high levels of suspended solids causing it can prevent light penetration needed for aquatic plant growth, can interfere with fish breeding, and can smother habitats. High turbidity levels can clog gills in fish and macroinvertebrates, affecting their growth and survival. High levels can make it difficult for sight-feeding predators, such as bass, pike, and trout to find their food, while other species like carp, which do not depend on sight to feed, are able to survive in the murky conditions.

### Materials

- Turbidity tube

### Method

- Step 1 In normal sunlight slowly fill the turbidity tube while looking down into it vertically until the cross on the bottom disappears.
- Step 2. Note the reading on the tube at the water level.
- Step 3. Record the NTU value.



Mick O'Connor

Figure 94.1 Turbidity tube

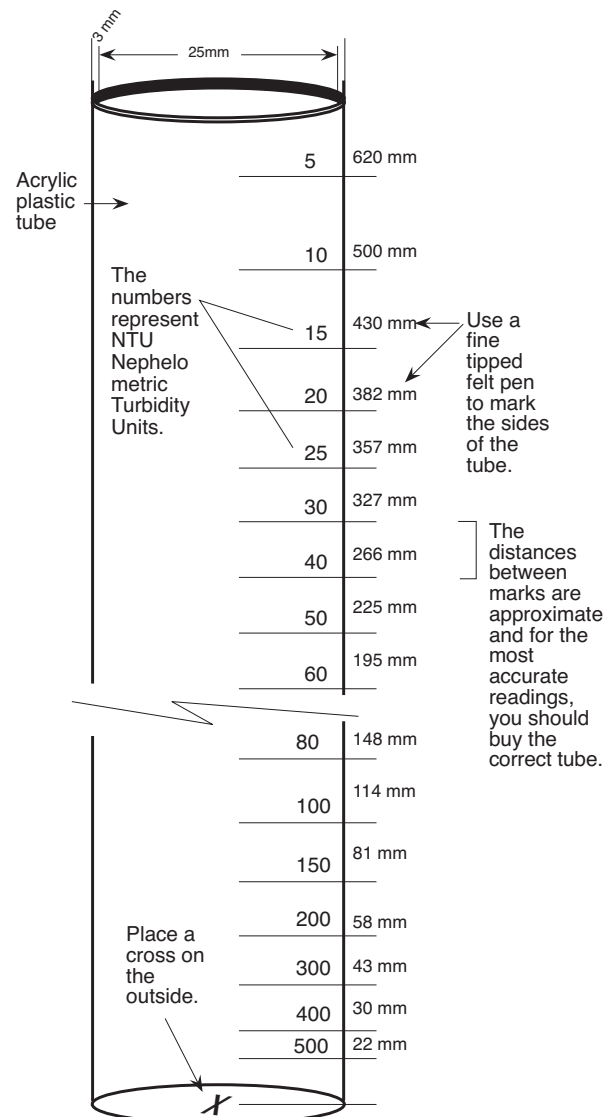
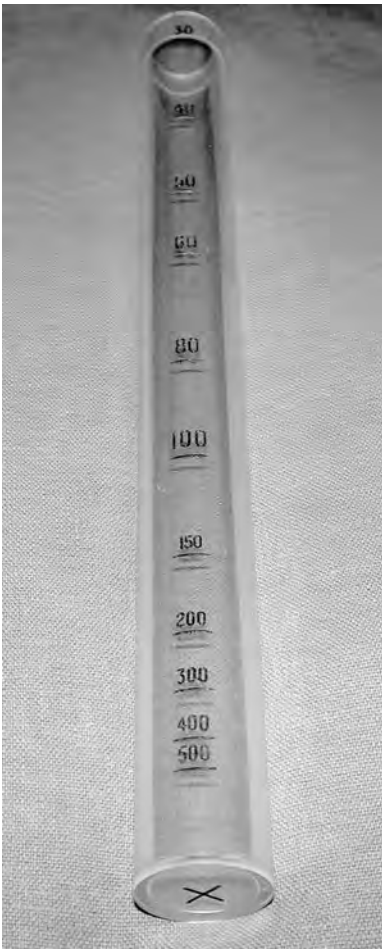


Figure 94.2 Turbidity tube measurements

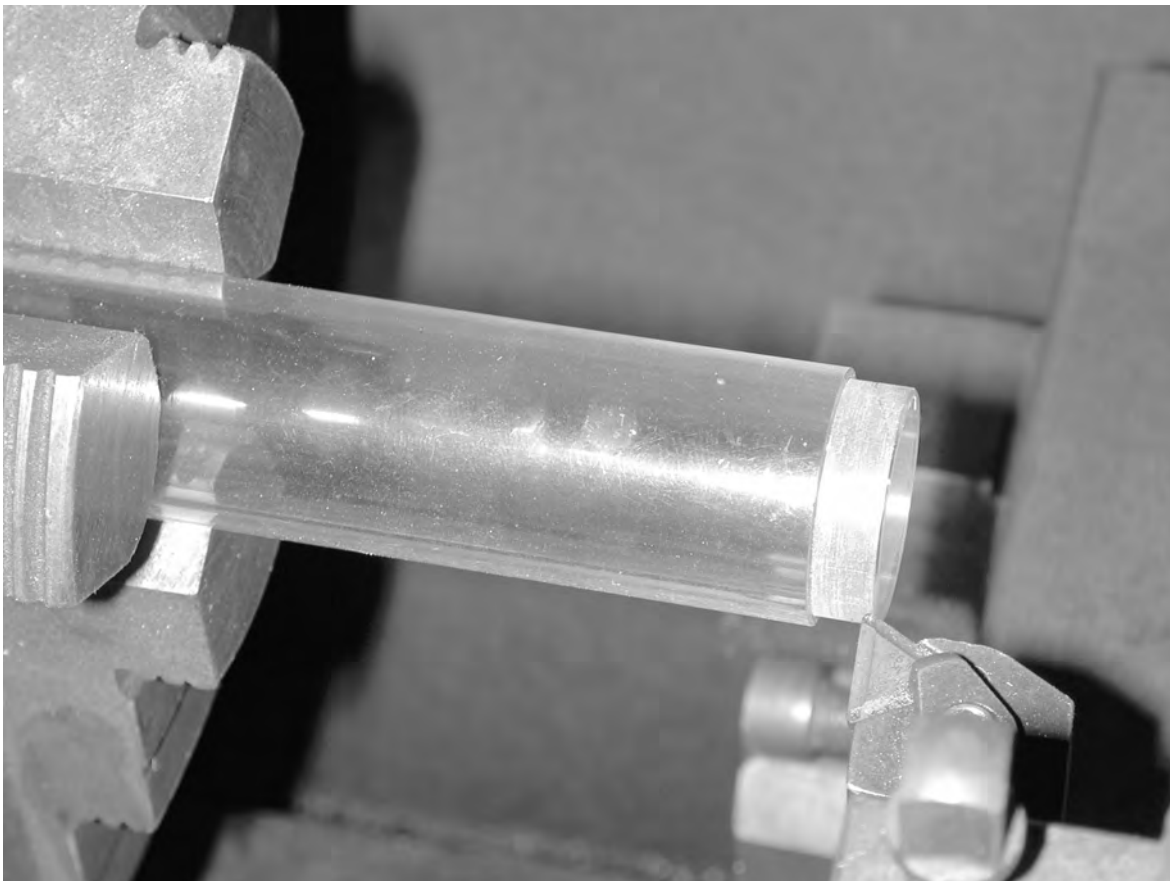
*Make your own*



Mick O'Connor



Mick O'Connor



Mick O'Connor

Figure 95.1 Make your own in industrial arts

## 2.6 Make a water sampler bottle

### Materials

See Figure 96.1

- Drink bottle and cap
- Venetian blind cord
- Duct or electrical tape
- Lead weight
- Wooden dowel (cut from broom handle)
- Drill and suitable bit

### Method

1. Take an empty plastic 1.25 litre PET bottle and place a weight underneath.

A diving weight as shown in Figure 96.1 will do.

2. Take some venetian blind cord and tie it to the weight and pass two ends up and around the neck of the bottle.
3. Now tape the weight to the bottom and the cord to the sides of the bottle as shown.
4. Wind on about 10 metres of cord to a piece of wooden dowel as shown and tie the other end to the bottle's neck.
5. To use the bottle, make sure you don't throw it more than 10 metres. The idea is to throw the bottle out from the shore or lower it from a boat with the top off.

Quickly retrieve the bottle and screw on the cap so you can take it to your portable lab.

### To make the bottle open at a set depth

1. Take an empty bottle and make a harness with a weight as shown in Figure 96.2.
2. Make sure you can find a cork that fits into the neck of the bottle that can support the weight of the bottle and weight.
3. Drill a hole on the cork so that you can make a trigger for the cork to pop when the bottle is given a sharp jerk.
4. Now make the trigger as shown in Figure 96.2.
5. Mark out 10 metres of venetian blind cord and test out in a 44 gallon drum.

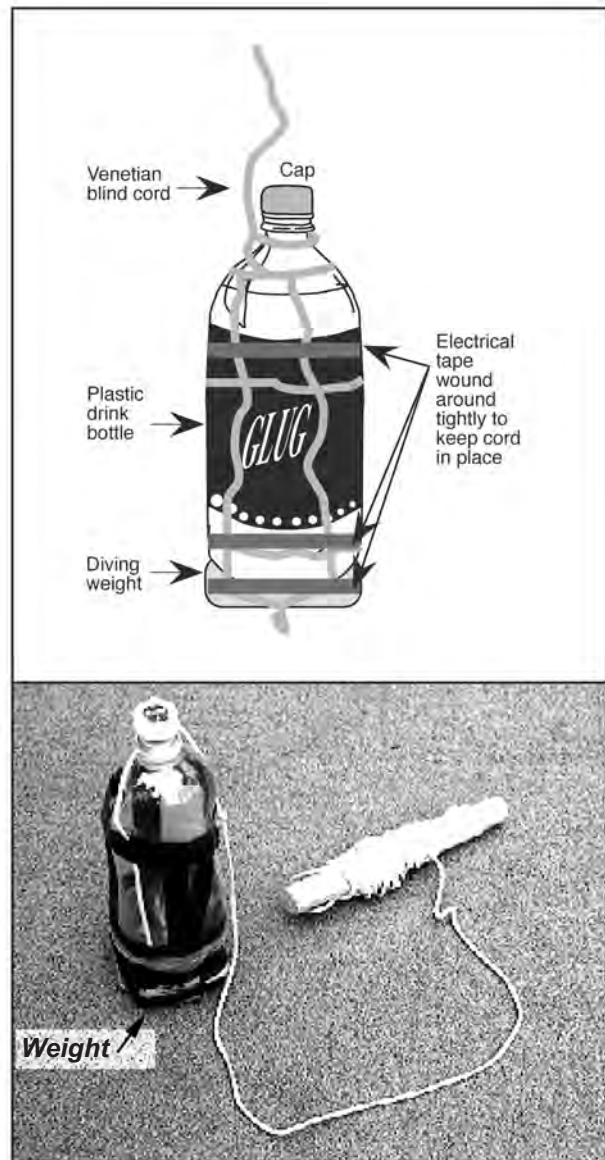


Figure 96.1 Home-made water sampling bottle

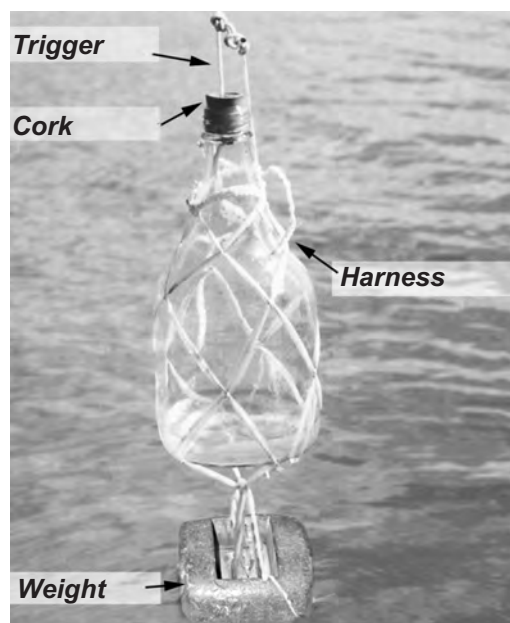


Figure 96.2 Homemade water sampling bottle with cork that opens at a set depth



## 2.7 Make a field thermometer

See Figure 97.1

### Materials

See Figure 97.2

- Drip system irrigation tube
- Electrical tape
- Gloves and cutting knife
- Cutting board
- Wiper sniper cord or fishing line
- Drain pipe and cap
- Plumbers glue adhesive

### Method

1. You can use a simple field thermometer with a protective plastic case as shown.
2. The plastic comes from a home drip system irrigation tube and is supported by a large amount of electrical tape.
3. To make this, cut a piece of drip irrigation system pipe just a bit longer than the thermometer.

Thread a piece of fishing line or wiper sniper cord through the top of the thermometer so it passes about 20 cm down each side.

Now insert the thermometer into the sleeve and tape the fishing line to the sides.

Cut out the areas of the thermometer you don't want. E.g. In Queensland you would not need the 0-10°C range but in Victoria and Tasmania you would.

Use electrical tape to strengthen and store in a piece of drain pipe with a cap as shown in Figure 97.2.

4. Make a storage container out of PVC pipe and glue on a removable cap (ask your hardware store what you need).



Figure 97.1 Using home made field thermometer



Figure 97.2 Home made field thermometer. A number can be stored in a sink drain pipe with a cap at each end.

## 2.8 Photic zone and turbidity

### Method

1. Use your home made secchi disc to determine the depth at which the white disappears. Use an area of the boat that is in the sun and get everyone in the group to take a measurement.
2. Record the four results in the space below and average them out.
3. Use the bucket and lanyard to collect a sample of water from the surface.
4. Pour this into the turbidity tube and record the depth at which the x at the bottom disappears.
5. Record your results in Figure 98.1

Depth of photic zone	Turbidity

Figure 98.1

*Map of study area*

### Questions

- Q1. Describe the study area and draw map in the box above.

---

---

---

---

- Q2. Describe how clear the water is. Give a reason for your answer.

---

---

- Q3. Define the term turbidity and how is it measured.

---

---

---

- Q4. Explain what do you think would cause a decrease in turbidity. Explain your answer.

---

---

---

---

---

## 2.9 Temperature and depth

### Method

1. Use your home made sampler bottle to collect a sample of water from the bottom.
2. Lower your depth gauge as well and determine the water depth. Make a note of any sediment on the depth gauge.
2. Haul up the bottle quickly so as not to mix the water.
3. Record the temperature and the depth.
4. Repeat for a sample taken from the middle of the water column and one from the surface.
5. Record your results in the space below.

*Map of study area*

	Surface	Middle	Bottom
Temperature			
Depths at which sample collected			

### Questions

Q1. Describe the study area and draw map in the box above.

---

---

Q2. Describe any difference in temperature. Give a reason for your answer.

---

---

---

---

Q3. Estimate the depth of water at your sample site and write down the type of sediment on the bottom.

---

---

---

---

---

---

---

## 2.10 Tides and currents

### You will need

- tide tables
- watch with second hand
- home made current drogue and rope (Figure 100.1)
- handbearing compass

### Method

#### Part A Tides

1. From a book on tides or your local newspaper, find out when high and low tide are today and complete the tide table in the figure on the page opposite.
2. Work out the tidal range and write it in the box in the figure on the page opposite.
3. Find out if tide affects the currents in this area. Summarise the answer in the figure on the page opposite.
  - Are there certain times between tides that are more dangerous and why?

#### Part B Currents

1. Collect the home-made current meter (called a drogue) you made for this exercise, a watch and a handbearing compass.
2. Tell your partner to hold the watch and that you are going to lower the drogue into the water. Arrange with your partner to time how long it takes for the drogue to run out to the full length of the rope.
3. On the count of three, release the drogue and observe what happens. Use the handbearing compass to determine the direction of ocean current.
4. Measure the length of the rope and calculate the speed and direction of the current as shown in Figure 107.2.



Figure 100.1 Homemade current drogue



Figure 100.2 Time and distance

Time	High tide height	Low tide height

Figure 101.1 Tide table

Tidal range

Figure 101.2 Calculation of tidal range

**The effect of tide on current**

---

---

---

---

---

---

---

---

---

---

---

---

Figure 101.3 Skippers tide and current answer

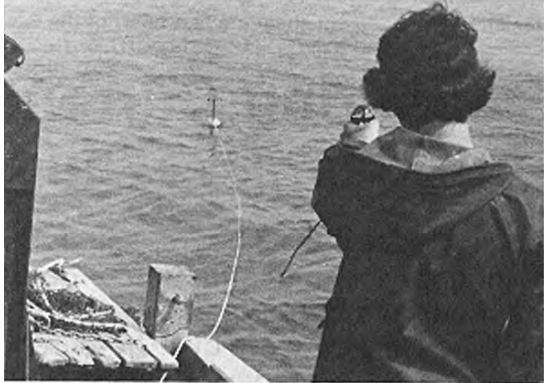
**Data**

Length of rope \_\_\_\_\_ Time to run length out \_\_\_\_\_

**Calculations**

Speed of current  
(Distance/time) \_\_\_\_\_

Direction of current \_\_\_\_\_



Bob Moffatt

Direction

Figure 101.4 Summary of current data

## 2.11 Salinity and pH

### You will need

- Refractometer (Figure 102.1)
- pH meter (Figure 102.3)
- Home-made water sampler bottle
- pH paper

### Method

1. Use your home made sampler bottle to collect a sample of water from the bottom.
2. Haul up the bottle quickly so as not to mix the water.
3. Use the refractometer to measure the salinity and write your result in the table below.
4. Now use the pH paper to record the pH and write your result in the table below
5. Repeat the activity for the middle and surface waters.

	Surface	Middle	Bottom
Salinity			
pH			



Figure 102.1 Refractometer



Figure 102.2 Salinity readings

### Questions

Q1. Determine if there are any difference in salinity. Give a reason for your answer.

---



---



---

Q2. Determine if the pH the same for all water levels. Give a reason for your answer.

---



---



---



---



---



---



---



---



---



---



Figure 102.3 pH meter

## 2.12 Dissolved oxygen

### *Dissolved oxygen meter and probe*

A dissolved oxygen meter is an electronic device in which oxygen diffuses across a membrane in a submerged probe, to complete an electrical circuit. It records the dissolved oxygen concentration in milligrams per litre or percentage saturation. Most meters also measure temperature. The advantage of this type of meter is that you can measure directly in the waterway.

### **You will need**

- dissolved oxygen meter and probe electrode (Figure 103.1)
- operating manual for the meter and probe
- extra membranes and electrolyte solution for the probe
- extra batteries for the meter
- home-made water sampler bottle

### **Method**

1. Turn the meter on and allow 15 minutes for the meter to reach equilibrium before calibrating.
2. Calibrate the meter before each use, according to the manufacturer's instructions. It can also be checked against readings from the Winkler method.
3. Place the probe in the stream below the surface (about wrist depth).
4. Set the meter to measure temperature and allow the temperature reading to stabilise. Record temperature reading on a water quality results sheet.
5. Switch the meter to read 'dissolved oxygen'. Record dissolved oxygen on the water quality results sheet.
6. If testing saline waters, measure the electrical conductivity level and record in a water quality results sheet.
7. Re-test water to obtain a field replicate result.

### **Calibration**

Be sure to calibrate the meter according to the manufacturer's instructions, before each use. The calibration values for temperature and altitude should be printed in the manufacturer's instructions.



Figure 103.1 Dissolved oxygen meter and probe

## 2.13 Making sand sieves

### To make sieves

1. Mesh of very fine mesh sizes is available from Swiss Screens, Randall St, Slacks Creek, Q'ld, 4127.
2. Plastic sieves as shown in Figure 104.3 are available from Hardie Iplex, in a trades pack of 10, and are called a weathering apron, 50mm, product code is VO 7450.
3. The silk comes in widths ranging from 900 - 1200mm and a 125mm long strip will make 9 sieves of the sizes mentioned above. If you use the 50mm weathering apron, then cut the 125mm strip into nine equal squares.
4. Use a rubber band as shown in Figure 104.3 to hold down the mesh and then add bondcrete glue around the rubber band.

Take the all weathering tape and bind the mesh to the sieve. Pull down the tape as you bind to make a strong seal. Allow to dry for 24 hours.

5. Make sure you mark the sieve with the correct size.

### Field work hints

1. Often it is impractical to take a balance into the field. In this case the use of small plastic containers as shown in Figure 104.3 may be of assistance.
2. You will need a labelled container for each sieve as shown in Figure 104.2
3. Use a rough estimation as shown in Figure 104.1 to work out the percent.
4. Use zip-top plastic bags to collect other sand samples that can be taken back to the lab and analysed if time permits.

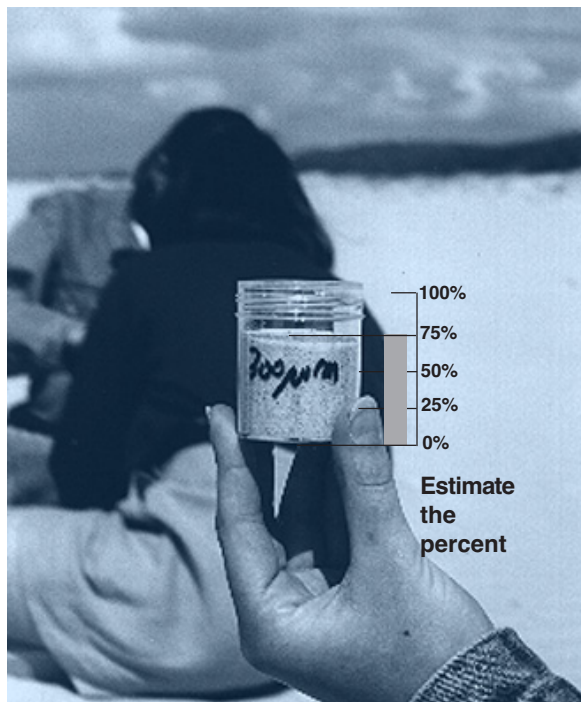


Figure 104.1 Estimating percentage

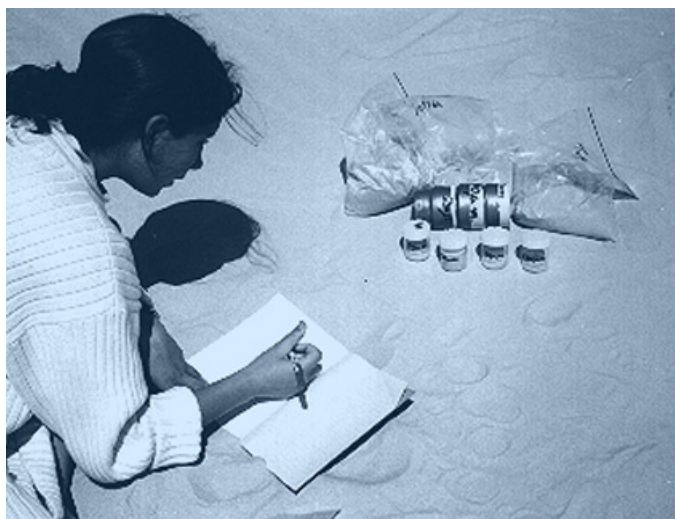


Figure 104.2 Comparing the different sieved samples



Figure 104.3 Materials necessary to make sieves





Geoff Jensen

Figure 105.1 For sand from coarse grained areas, a larger sieve needs to be used. (Photograph Geoff Jensen)



Bob Moffatt

Figure 105.2 Swirl the sieves to separate out the sand grains

## 2.14 Wheelhouse instruments

### **Method**

1. Visit the wheelhouse and make notes on the use of each of the following instruments.
2. Write down the instrument's name and a brief description of what the instrument does to help the skipper.

Name of instrument	Description of use
<hr/>	
<i>Marine radio</i>	<hr/> <hr/> <hr/> <hr/> <hr/> <hr/> <hr/>
<i>Radar</i>	<hr/> <hr/> <hr/> <hr/> <hr/> <hr/> <hr/>
<i>Navigation charts</i>	<hr/> <hr/> <hr/> <hr/> <hr/> <hr/> <hr/>
<i>Echo sounder</i>	<hr/> <hr/> <hr/> <hr/> <hr/> <hr/> <hr/>
<i>Microwave</i>	<hr/> <hr/> <hr/> <hr/> <hr/> <hr/> <hr/>

## 2.15 Plankton sample

### Method

1. Collect a plankton net and identify the rope, chains, collection bottle, shackles and bolting silk.
2. Secure one end of the rope with a good holding knot - round turn and two half hitches or bowline (the skipper can help with this).
3. Ask the skipper to steam at 2 knots or if there is a strong current ask him or her to anchor.
4. Lower the net in the water and let it run out and trail for about five minutes.
5. Set up a microscope and petri dish while you wait.
6. Now haul the net in as shown in Figure 107.1 and unscrew the bottle. Tip the contents into a holding container and divide up the contents into a set of test tubes.
7. Pass these around and examine them as shown in Figure 107.2
8. Write a description of these in the space below.

### You will need

- Plankton net
- Small sample of fresh plankton
- A test tube and magnifying glass as shown in Figure 107.2
- Note book and pencil
- Microscope and petri dish

### Questions

Q1. Name three common plankton.

---

---

---

Q2. Explain why plankton are important animals and plants.

---

---

---

Q3. Describe the plankton you see in the space below.

---

---

---

---

---

---

---

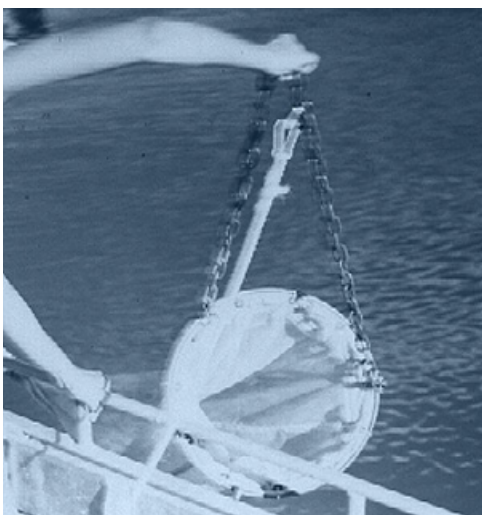


Figure 107.1 Hauling in the net



Figure 107.2 The test tube microscope

## 2.16 Making a beach walkway

The exercise focuses on beach management procedures.

### Method

1. Find out who is responsible for local beach management in your area and obtain permission to build a walkway to your local beach.
2. Submit the plans similar to those opposite and obtain relevant approvals. Use the materials as outlined in Figure 108.1 as the basis for your fence.
3. Apply for a grant and gain community support for the project.
4. Prepare a statement of what you intend to do and do a letter box drop to local residents in the area.
5. Write a press release for local media and ring them up and ask for a journalist to help write an article.
6. Finally assemble the materials and construct your walkway.
7. Build a sign saying what the project is about and ask a local member of council to officially open the walkway.
8. Make a study of the effect of the walkway and how it fails or succeeds in conserving sensitive dune areas.

### Materials and equipment (per group)

#### Equipment required

- fence posts as detailed
- plastic coated fence wire
- wire twitchers
- shovels
- large hammer
- camera
- sign - find a friendly signwriter

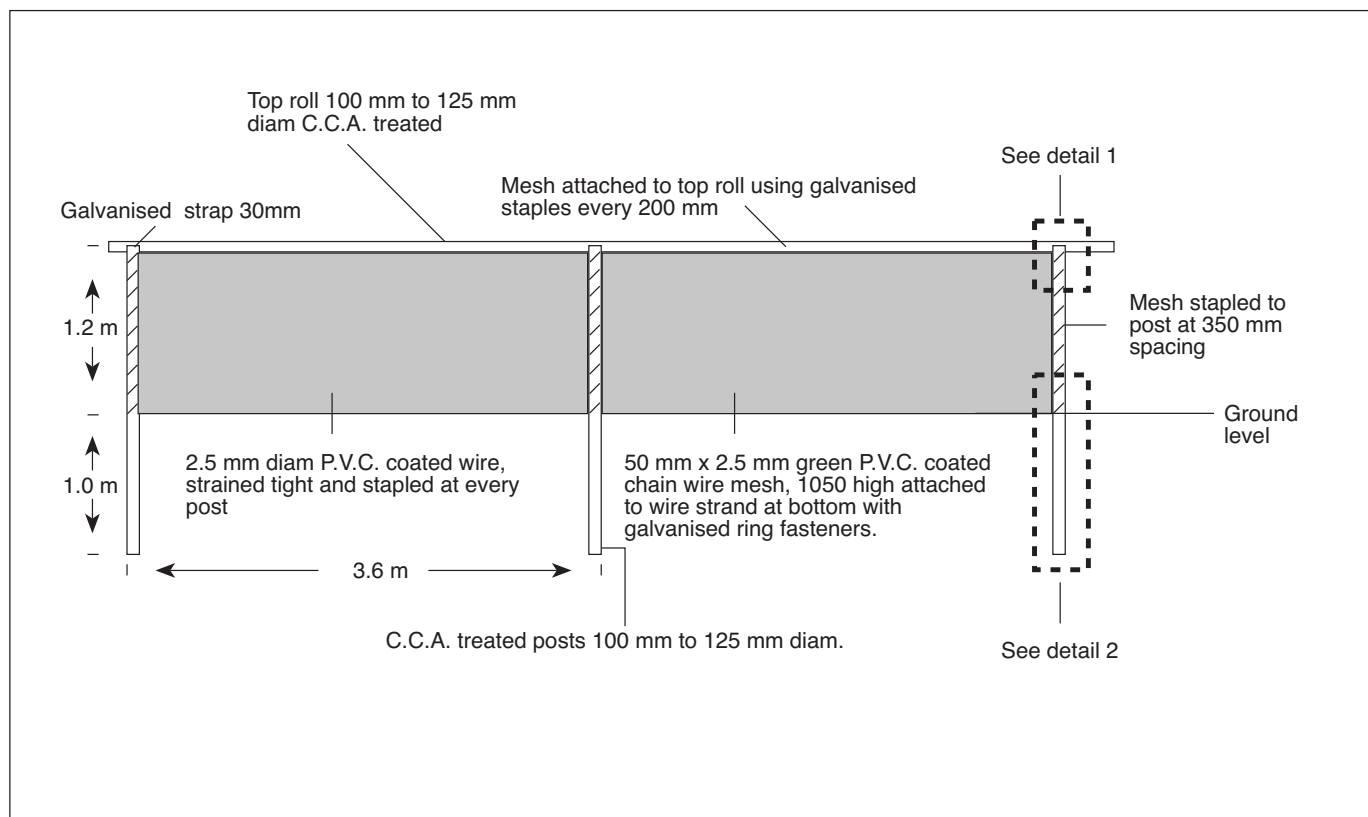


Figure 108.1 Construction details (GCCC - Special Projects)



Figure 109.1 Completed fence

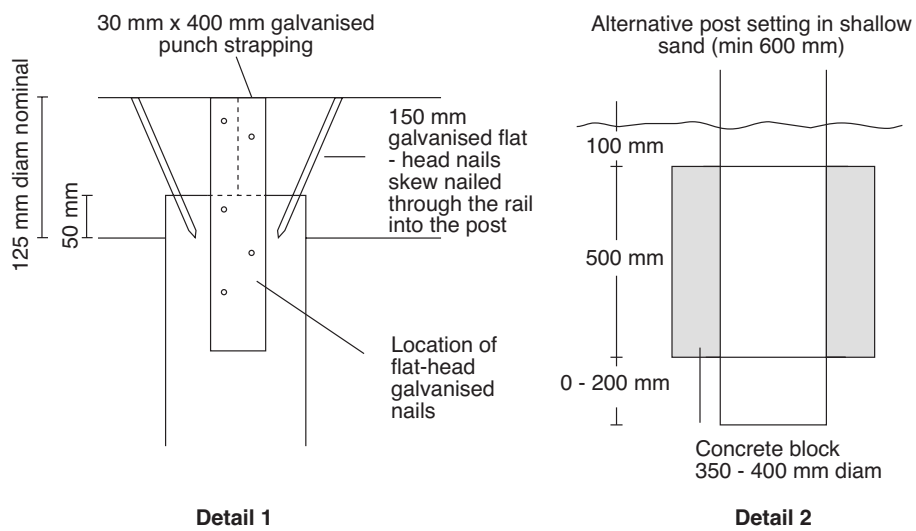


Figure 109.2 Details 1 and 2 from Figure 29.1 (GCCC - Special Projects)

# Appendix 3 Laboratory work

## 3.1 Weather front demonstration

### Aim

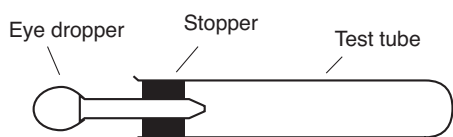
To observe what happens when two different temperature fronts collide.

### Materials

- Food colour dye
- 2 eye droppers fitted with rubber corks
- bunsen, tripod, gauze mat, bench protector
- beaker
- 2 test tubes

### Method

Set up the test tubes as shown by the diagram below.



### Part A. Cold front

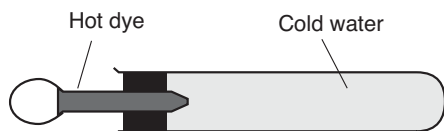
1. Fill test tube with hot water and set up as shown in the diagram below.



2. Add cold dye slowly and record what happens.

### Part B. Warm front

1. Heat some dye in a beaker using the bunsen.
2. Fill test tube with cold water as shown in the diagram below.

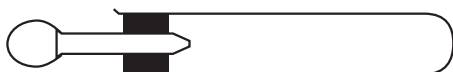


3. Add hot dye slowly and record what happens.

Cold dye injection



Warm dye injection



### Teacher feedback

I've done something similar years ago with red dye (hot water) and blue dye (warm) in a 4 foot fish tank with a divider in the middle. Fill both sides, remove divider, and away you go! Get a bit of mixing and swirling when the barrier is removed.

Similarly I have demo'd convection currents in the ocean by heating water (not boiling) in a large beaker over a bunsen, and adding a couple of KMnO<sub>4</sub> crystals. The colour rises. I then put an ice cube with loads of food colouring in it into another beaker. The colour falls. When both the diagrams are combined, it nicely complements the onshore/offshore wind diagrams.

### Conclusion

The dye and water in the experiment represented two air masses.



**Results**

**Part A**

Q3. Identify which pencil floated higher.

\_\_\_\_\_

Q4. Give a reason for your answer.

\_\_\_\_\_  
\_\_\_\_\_  
\_\_\_\_\_  
\_\_\_\_\_  
\_\_\_\_\_

**Part B**

Q5. Complete the data table above.

Q6. Plot a graph of the standard solution (x axis) versus the hydrometer reading (y axis).



Describe how the graph changes.

\_\_\_\_\_

Q7. Describe what a hydrometer measures.

\_\_\_\_\_

Q8. Explain which is more dense: salt water or fresh water.

\_\_\_\_\_

Q9. If the tide was coming into a river, would seawater be found on the top of the fresh water or the bottom?

\_\_\_\_\_

Q10. Describe a salt water wedge in an estuary.

\_\_\_\_\_  
\_\_\_\_\_  
\_\_\_\_\_

Data table

Standard solution	Hydrometer reading
0 g/L	
10 g/L	
20 g/L	
30 /L	
35 /L	

Figure 112.1 Data table



## Laboratory work 3.2 - suggested answers

### Questions

Q1. Make a list of the materials you could use in this experiment.

*Part A: 100 mL beaker, 5 test tubes (equal size), 2 pencils, test tube rack,*

*100 mL beaker, teaspoon and salt*

*Part B: 5 test tubes (equal size), pen and ruler, 10 mLs of 5*

*saltwater standard solutions labelled*

*0, 10, 20, 30 and 40 grams per litre*

Q2. Write an experimental procedure and draw a diagram of the experimental set up in the space below.

*Part A*

*1. Sharpen two pencils to exactly the same length.*

*2. Now dissolve a teaspoon of salt in 100 mLs of water.*

*3. Place the two test tubes in the rack provided and 3/4 fill one with fresh water and the other with salt water.*

*4. Now place the pencils in each and note the very small difference in height.*

*Part B*

*1. Now take out one of the pencils and use a pen and ruler to mark down 0.5 cm intervals*

*2. Fill each of the 5 test tubes with the solutions labelled 0, 10, 20, 30, and 40 grams per litre.*

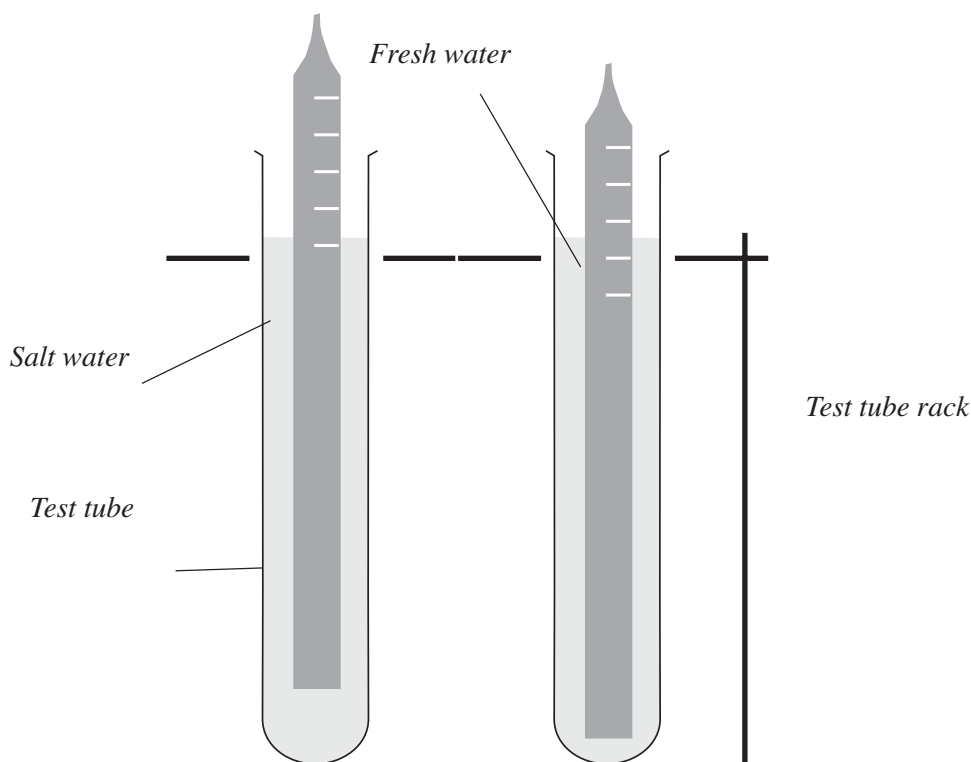
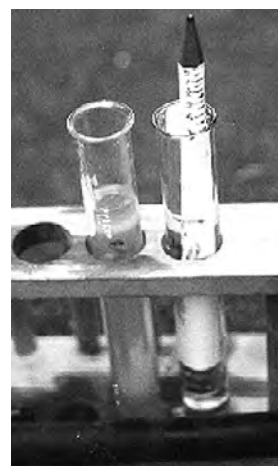
*3. Now carefully drop the pencil into each test tube as shown in the photograph.*

*4. Read the scale and record your results in the Table on the page opposite 2.*

*5. Repeat the experiment with the other test tubes.*

### Option

You may wish to use a commercial hydrometer and graduated cylinder for this experiment if available.



## Laboratory work 3.2 - suggested answers

### Results

#### Part A

Q3. Identify which pencil floated higher.

*The one in the saltier water*

Q4. Give a reason for your answer.

*Density pushes up the pencil*

#### Part B

Q5. Complete the data table above.

Q6. Plot a graph of the standard solution (x axis) versus the hydrometer reading (y axis).

Data table

Standard solution	Hydrometer reading
0 g/L	
10 g/L	
20 g/L	
30 /L	
35 /L	

Figure 114.1 Data table



Describe how the graph changes.

*Should change with salinity.*

Q7. Describe what a hydrometer measures.

*The density of the liquid*

Q8. Explain which is more dense: salt water or fresh water.

*Salt water is more dense*

Q9. If the tide was coming into a river, would seawater be found on the top of the fresh water or the bottom?

*Fresh water should float on top of the salt water*

Q10. Describe a salt water wedge in an estuary.

*A line where salinity changes quickly. As the tide comes in bringing salt water, the salt water slips under the fresh water from the river.*

### 3.3 How do offshore winds occur?

#### Aim

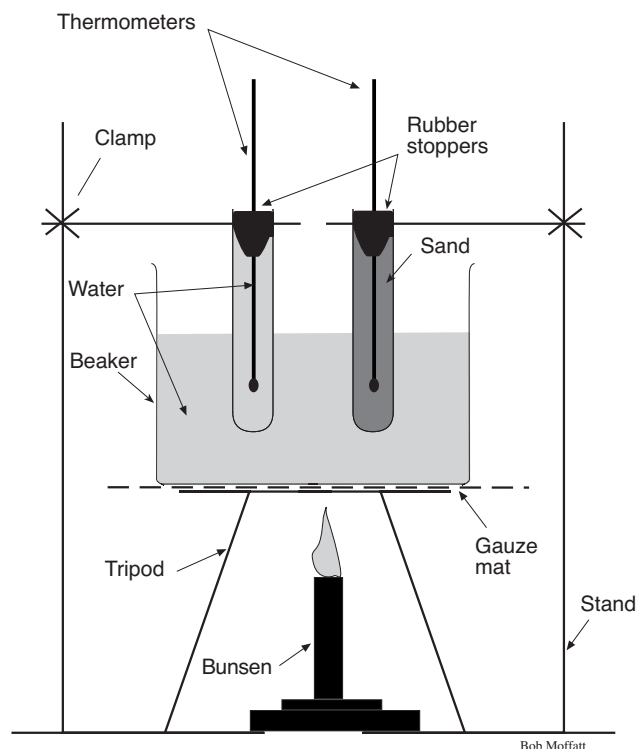
To observe the effects of temperature on land and water.

#### Equipment and materials

- 500 mL beaker half-filled with water
- 2 test tubes filled with equal amounts of dry sand and water
- 2 thermometers tight fitted in rubber stoppers, 1 in each test tube
- bunsen burner, tripod, gauze mat, matches
- bench protector, 2 retort stands, bossheads and clamps

#### What to do

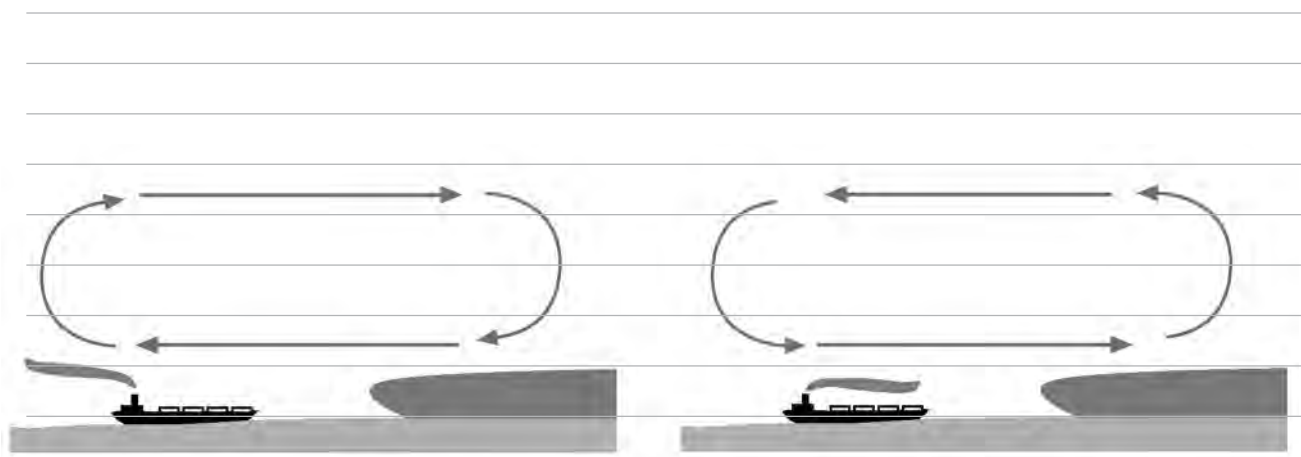
1. Set up equipment as in the illustration opposite.
2. Read and record temperatures of sand and water (time = 0)
3. Light bunsen and heat beaker over a low flame for 10 minutes, reading temperatures of sand and water every 2 minutes.
4. After 10 minutes, turn off bunsen and lift both test tubes from water with gloves/tongs (ask you teacher)..
5. Allow to cool and read both temperatures every 2 minutes for 10 minutes.
6. Draw a line graph of temperature versus time, comparing the sand and water data on the one graph. Note: Put the time (in minutes) on the horizontal axis.
7. Now read page 74 - 75 of your textbook and answer the questions below.



#### Questions

- Q1. Write up your experiment under the headings aim, method, results and conclusion on the page opposite.
- Q2. Record which thermometer heated up and cooled down the fastest.

- Q3. Explain how offshore winds occur and relate this to the above experiment. Complete the illustration below to illustrate your answer.



- Q4. List three important oceanographic features about winds (see pages 74 - 75 of your textbook)

---



---



---

**Experiment title**

**Aim**

**Method**

**Results**



A large grid of graph paper for recording results, consisting of 20 columns and 25 rows of small squares.

**Conclusion**

### Laboratory work 3.3 - suggested answers

#### Questions

- Q1. Write up your experiment under the headings aim, method, results and conclusion on the page opposite.
- Q2. Record which thermometer heated up and cooled down the fastest.

*The sand cooled down the fastest*

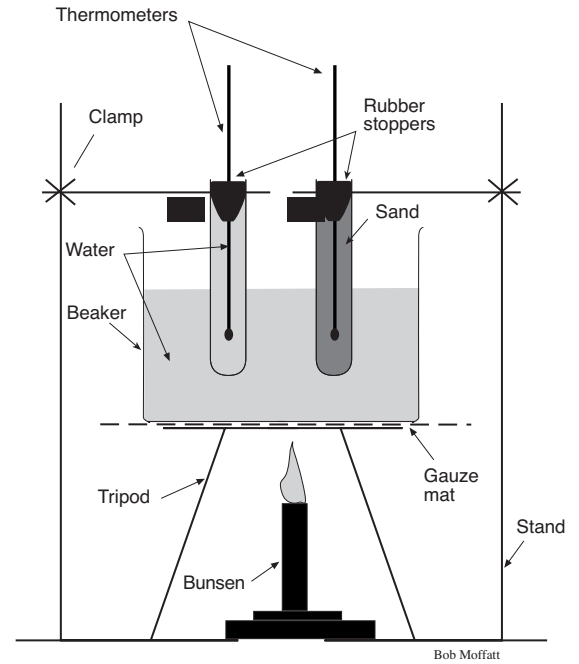
- Q3. Explain how offshore winds occur and relate this to the above experiment. Complete the illustration below to illustrate your answer.

*At night the land cools down faster and air sinks*

*setting up a wind that blows offshore.*

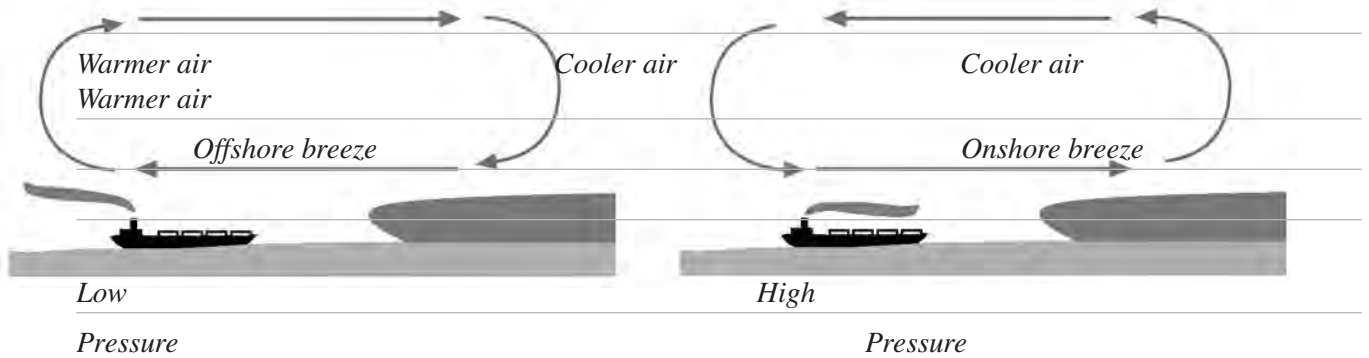
*This is shown in the above experiment by the fact*

*that sand cools down faster than water.*



*Morning*

*Afternoon*



- Q4. List three important oceanographic features about winds (see pages 74 - 75 of your textbook)

*They form waves*

*Control the direction of swells*

*Determine safety and comfort to study the marine environment*

### 3.4 Can we recover salt from the sea?

An original exercise by Bob Moffatt

#### **Aim**

To recover salt from seawater.

#### **What to do**

- Read pages 138 of your textbook and answer the questions below.

#### **Safety warning**

When the sea water solution has nearly all evaporated, it may "spit" up. To stop this remove the flame and let the remainder evaporate under its own heat. All equipment will get very hot after a short time, so make sure you let it cool before touching it. Use gloves or tongs for hot materials.

#### **Questions**

Q1. Name the pieces of equipment used in this experiment.

---

---

Q2. Describe the experimental procedure.

---

---

---

---

---

---

---

---

---

---

Q3. Describe what happens to the water as it heats up.

---

---

Q4. Describe what happens when salt water evaporates.

---

---

Q5. Describe what happened when almost all the water was gone.

---

---

Q6. Estimate if you got the same amount of salt back.

---

---

Q7. Define the terms solute, solvent and solution and give an example from this experiment.

---

---

---

---

## Laboratory work 3.4 - suggested answers

An original exercise by Bob Moffatt

### Questions

Q1. Name the pieces of equipment used in this experiment.

*Methylated spirits burner, safety goggles, table salt, fireproof mat, matches, oven mitts*

*very clean 50 mL conical flask, glass stirring rod, filter paper, tap water*

*tea spoon*

Q2. Describe the experimental procedure.

*Use gloves or tongs for hot materials*

*a. Measure out half a teaspoon of salt and empty it into the conical flask.*

*b. Now add enough water to cover and dissolve the salt.*

*c. Set up the equipment as shown in Figure 1.1. Now light the spirit burner by using the manufacturers instructions and adjust the burner to produce a gentle flame under the flask.*

*d. Put on the safety goggles and keep them on until all the salt has evaporated (see safety warning).*

*e. When the water has nearly all evaporated, extinguish the burner and let the flask cool.*

*f. Take the stirring rod and scrape the salt out and onto a piece of filter paper.*

Q3. Describe what happens to the water as it heats up.

*The water starts to evaporate from the bottom of the flask and the temperature rises. You can see steam on top of the water.*

Q4. Describe what happens when salt water evaporates.

*Pure water comes off the top and salt water is left behind.*

Q5. Describe what happened when almost all the water was gone.

*The salt starts to spit up and crackle.*

Q6. Estimate if you got the same amount of salt back.

*Students own answer - mostly no*

Q7. Define the following terms and give an example from this experiment.

*Solute - the material dissolved in the water eg the salt.*

*Solvent - the liquid the solute dissolves in - eg the water.*

*Solution - the combined amount of solute and solvent eg - the salt water solution.*

### 3.5 Beach formation and erosion processes

#### Method

##### Part A

1. Collect the materials for a wave tray experiment.
2. Make a beach with an offshore gutter and sand bank as shown in the figures on the page opposite.
3. Generate very small rapid waves so that they pass just over the offshore sandbank as shown in Figure B on page opposite.
4. Observe what happens to the sand on the bank and record the direction it moves.

##### Part B

1. Reconstruct your beach as shown in the figure on the page opposite.
2. Generate larger waves and observe what happens to the sand on the beach. Record your observations.

#### Materials and equipment (per group)

##### Equipment required

- white tote tray (tidy box)
- sand
- water and jug
- wave generator (a block of wood the width of the tote tray)

#### Questions

Turn to your textbook and answer the following questions.

- Q1. Define the term wave bore. Draw a diagram to illustrate you understand what happens when small waves with small orbit fields pass over an offshore sandbank.

---

- Q2. Explain what a microridge is and what it contains.

---

- Q3. Define the term *swash zone*.

---

- Q4. Draw a diagram of beach building conditions showing strong winds, primary and secondary dunes.

---

---

---

- Q5. Explain the role trees play in a secondary dune system.

---

- Q6. Define the term *accreting beach*.

---

- Q7. Explain what happens when large waves approach an accreting beach system.

---

- Q8. Explain what happens to sand on an accreting beach system.

---



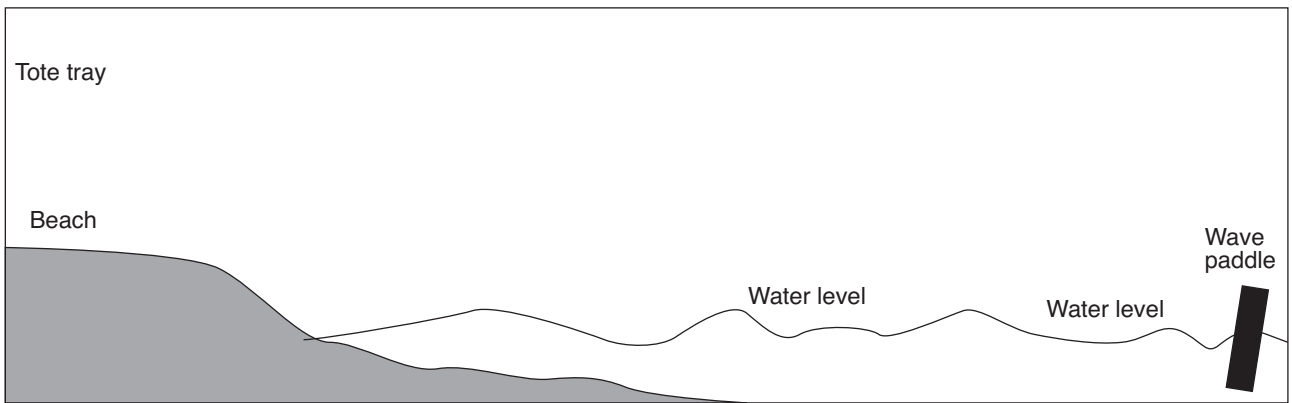


Figure 121.1 Setup for Part A: Wave tray arrangement for constructive waves

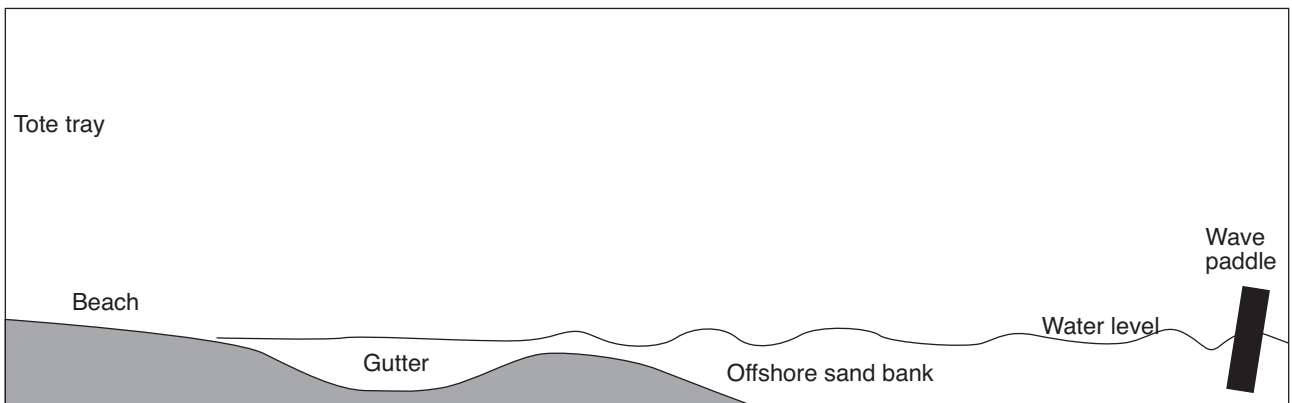
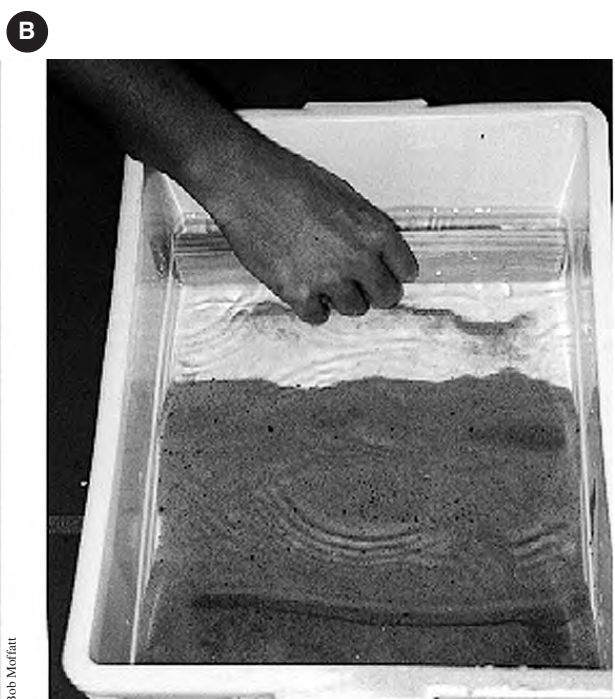


Figure 121.2 Setup for Part B: Wave tray arrangement for destructive waves



121Figure .3 How to study the effect of waves on an offshore storm bar

## 3.6 Wave velocity

### Method

1. Read the information box opposite.
2. Use the ruler to mark two points 15 and 30 cm out from the end of the tray as shown in the figure (page opposite).
3. Now fill the tank with 700 mLs of water and place the piece of wood at one end.
4. Practise rocking the piece of wood with your finger as shown so that a wave can be made to travel from one end of the tray to the other.
5. Now make a wave 15 cm long by consistently rocking the piece of wood at the same frequency.

When the wave length is 15 cm, count how many waves pass the 15 cm mark in 15 seconds using your watch.

- Record the number in Figure 123.2 in the frequency section under the 15 cm wavelength.
  - Calculate the velocity of the 15 cm long wave in cm/sec by using the formula supplied and write it in the space provided.
6. Now make a wave 30 cm long and again count how many waves are produced in 15 seconds using your watch.
    - Record the number in Figure 123.2 in the frequency section under the 30 cm wavelength.
    - Now calculate the velocity of the 30 cm long wave as before and write your result in the space provided.

### Questions

- Q1. Recall a definition for wave speed.
- \_\_\_\_\_
- \_\_\_\_\_
- Q2. Name the term for the distance between waves.
- \_\_\_\_\_
- Q3. Name the term for the number of waves per second.
- \_\_\_\_\_
- Q4. Complete the sentences:
- a. We observed 20 waves passing the 15 cm point in 10 seconds.  
The \_\_\_\_\_ of these waves is therefore 2 waves per second.
  - b. Waves of different frequency in the same depth of water have different \_\_\_\_\_ .
  - c. Waves of different frequency in the same depth of water have the same \_\_\_\_\_ .

### Materials and equipment (per group)

#### Equipment required

##### Part A

- white tote tray (tidy box)
- 700 mLs of water
- ruler and permanent felt pen
- timer with second hand
- 2 lengths of wood 50mm x 25mm (see Figure 123.1)

##### Part B

- two cups of washed sand
- 10 small rocks (optional)

### Information box

The speed at which waves travel is related by three things or variables in this experiment.

- The distance between waves is called the wavelength and has the symbol

lambda ( $\lambda$ ).

Distance is measured in kilometres or metres.

1 km = 1000 m

- The number of times a wave passes a point in a second is called the frequency and has the symbol ( $f$ ).

Time is measured in hours or seconds.

1 hr. = 60 x 60 seconds

- The speed that the wave is travelling is called the velocity and has the symbol ( $v$ ).

Velocity has a direction and a speed.

Direction can be up, down, north, south, east or west.

Speed is measured in Km/hr or m/sec.

Now these three variables are related by the formula:

Velocity = wavelength x frequency

or  $v = \lambda f$

In this experiment we want to investigate each and get some practice at using the

Figure 122.1 Information on wave velocity

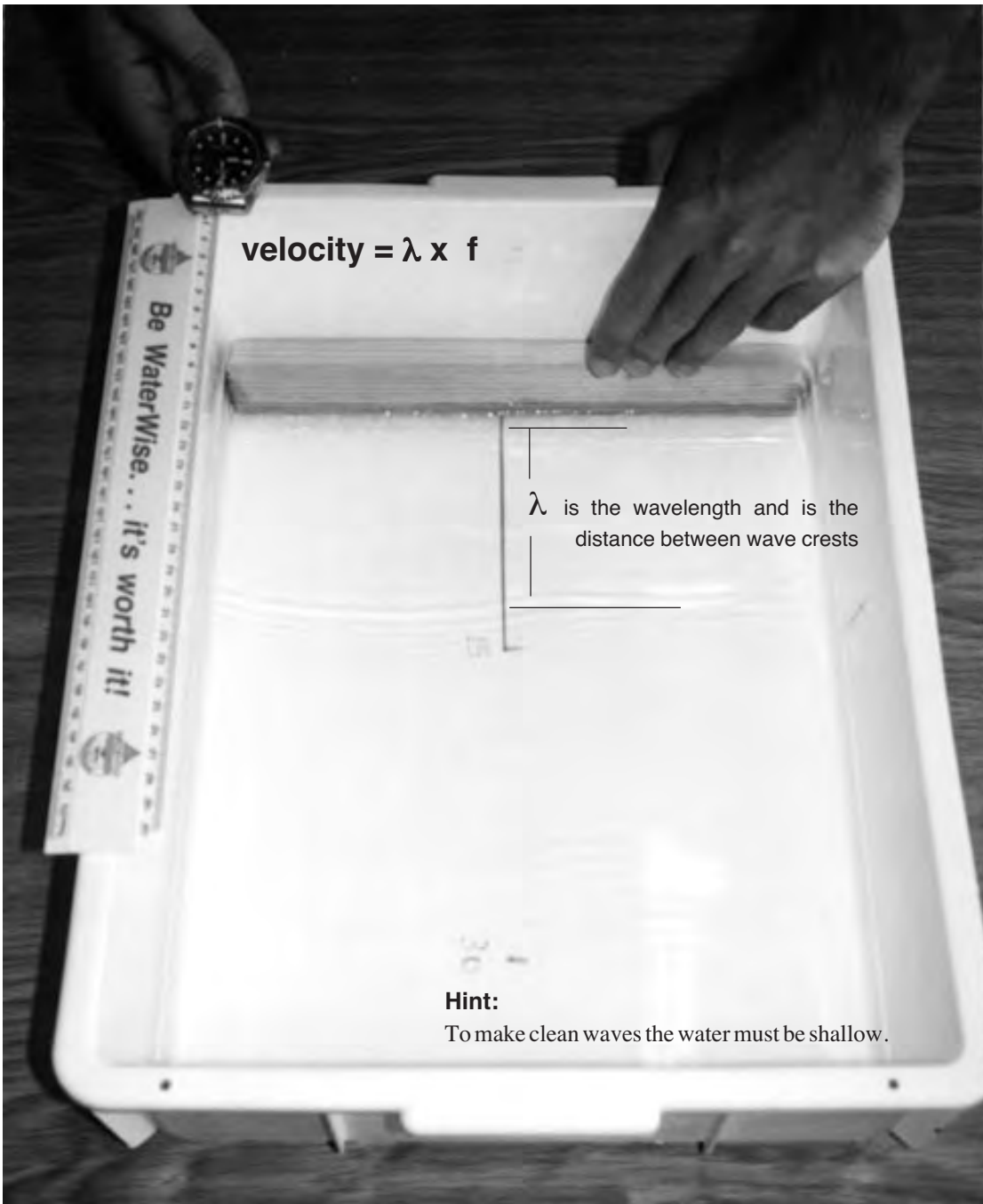


Figure 123.1 How to calculate the velocity of waves

Wave length	15 cm	30 cm
Frequency		
Velocity $v = \lambda f$	$v = 15 \times \frac{\quad}{15}$  = $\quad$ cm/sec	$v = 30 \times \frac{\quad}{15}$  = $\quad$ cm/sec

Bob Moffatt

Figure 123.2 Velocity of waves

## 3.7 Wave refraction and sand movement

An original exercise by Bob Moffatt

### Aim

To demonstrate sand movement and wave refraction in a tray.

### You will need

- White carry tray from science lab, fine washed sand from primary dunes, piece of 2x1 timber to fit into tray, smaller piece of 2x1 as shown in Figure 124.1, cup, towel, dye, paddle pop stick (condys crystals or food colouring).

### What to do

- Put a 15cm line in the bottom of the tray as shown in Figure 124.1 and fill the tray with enough water to cover the bottom.
- Place the wood block in the tray and practise generating waves that are 15 cm apart. When you have mastered this you are ready to begin.
- Add sand to the tray to make a shallow sandbank as shown in Figure 124.1. Use the short piece of wood as shown in Figure 124.2 to make an even sloping beach by smoothing out the sand bank so that the wave can travel over it.

- Add water carefully to the tray so that it just covers the bottom.
- Generate waves of about 15 cm wavelength and observe carefully what happens when the wave passes over the sandbank.

Make a drawing of the experimental set up and record your results.

- Add another cupful of sand to make a headland as shown in Figure 124.3 and generate waves to pass the headland.

Watch carefully what happens and the direction the waves are travelling as they pass the headland. Record your results.

- Add a few drops of dye or few grains of condys crystals as shown in Figure 124.4. Now generate waves and observe what happens to the dye. Make a drawing of your results and answer the questions below.

### Questions

Q1. Write up your experiment under the headings aim, method, results and conclusion on the page opposite.

Q2. Describe what happens to waves as they travel into shallow water.

*They slow down and bend.*

Q3. Explain why this is so.

*The friction from the sand closest to the beach absorbs the energy from the wave slowing it down.*

Q4. Define the terms refraction and wavelength.

*Refraction is when a wave bends as a result of shallow water around a point.*

*Wavelength is the distance between waves.*

Q5. Describe what happens as waves enter a bay.

*As the waves refract into the bay they spread out in a semi circle.*

Q6. Name the term used to describe your answer to Q5.

*Diffraction*

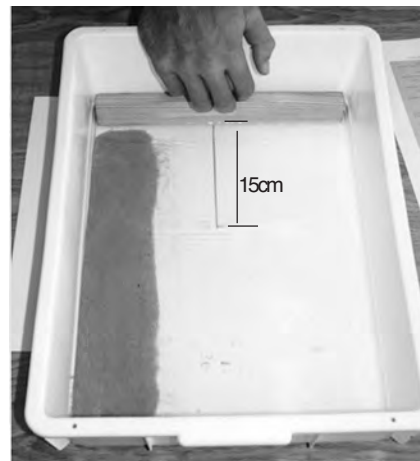
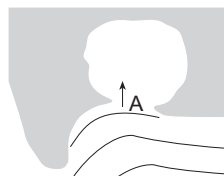


Figure 124.1 Add sand to the tray.



Figure 124.2 Make an even flowing beach.



Figure 124.3 Add more sand to make a headland.



Figure 124.4 Add a speck of dye to see what happens.

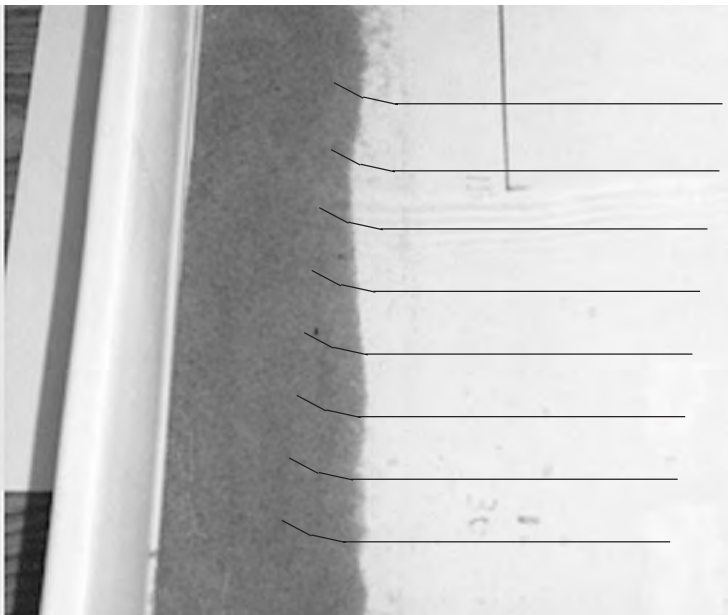
**Experiment write up**

*Title*

*Aim*

*Method*

*Results*

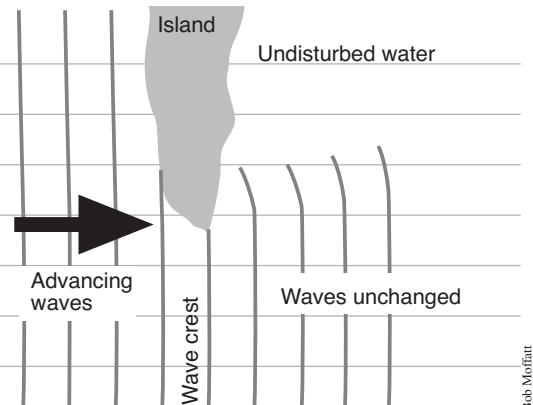


**Conclusions**

1. As waves pass into shallow water they bend or refract.
2. As waves pass around a point they refract.

**Teaching note:**

Diffraction usually happens when waves encounter a surface piercing obstacle, such as a breakwater or island. The turning of the wave is due to changes in the wave height along the crest in the same wave.



## Groynes

1. Read the information about groynes in 126Figure 1.
2. Empty the water out of your tray and construct a groyne in your beach out of the rocks supplied.
3. Now generate waves at the groyne and observe the movement of sand around the rocks.
4. Answer the questions below

## Questions

- Q1. Explain the term *groyne* and describe how it is different from a training wall?

---

---

---

---

---

---

---

---

---

---

- Q2. Draw the movement of sand around a groyne and describe what happens.

---

---

---

---

---

---

---

---

## Research

Research the role of a coastal engineer and describe what type of projects they undertake.

## Groynes

Sometimes rocks or training walls are placed in position to trap sand or reduce the wave action at river mouths so ships can enter and leave local fishing ports.

Rocks that are placed out to sea to alter the patterns of waves at river mouths are called training walls.

Rocks that are placed in the surf zone to trap sand are called groynes as shown in the figure below.

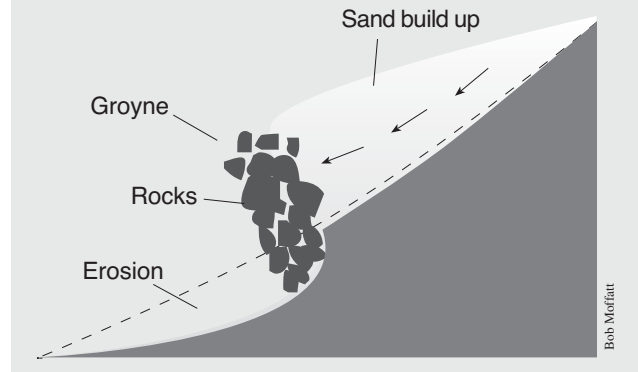


Figure 126.1 Groynes

### 3.8 Materials used in boats

The marine environment contains salt which is extremely corrosive.

To prevent things falling apart in seawater, the marine industry has developed combinations of materials that will last a long time in salt water.

#### Method

1. Fill a series of bottles or test tubes with seawater like the ones shown in Figure 127.1
2. Place a small amount of material in each bottle or tube and label each tube or bottle.
3. Draw up a data table like the one shown below and keep a record of the effects of seawater over time on the various materials.

Data table		
Date	Material	Observations

#### Questions

- Q1. Describe the effects of salt on the materials in each of the bottles.

---



---

- Q2. Explain which materials would you not recommend for use in the marine environment.

---



---

- Q3. Recommend which materials seem to be the best giving a reason for each.

---



---



---



---

#### Materials and equipment (per group)

##### Equipment required

- small pieces of the following materials:  
iron nail, stainless steel, chipboard, marine ply, plastic, nylon rope, hemp rope, galvanised iron or other materials, brass screw, stainless steel screw, iron screw, fibreglass
- bottles or test tubes as in Figure 20.1
- seawater
- labels and pencil

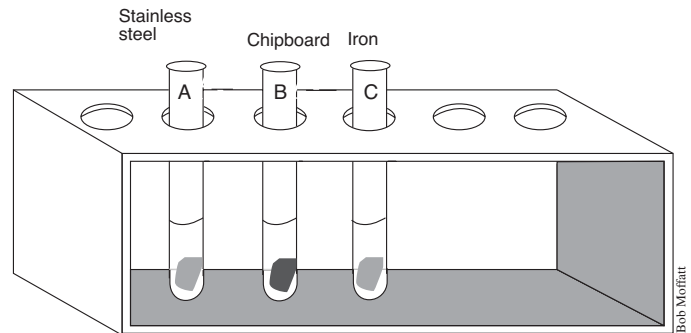


Figure 127.1 Experimental set up

#### Research assignments

1. Try some combinations of materials in a jar. For example:
  - a. Metal screw with particle board
  - b. Brass screws with marine ply
  - c. Stainless steel screws with galvanised iron. Study the effects over a two-week period and record observations.
2. Try different sealants between metal, such as silicone or barrier creams.
3. Make up a rivet plate with different types of rivets — stainless steel or mono.
4. Join two metals together or metal to wood and study the effects.
5. Visit a boat building yard or boat retail shop and record which materials are commonly used on boats and in what places.

Which is the most expensive and where is it used?

## 3.9 Orbit fields

### Method

1. Ask your friendly Manual Arts Teacher to help you build your wave tank out of scrap wood, fibre glass and plastic as shown in the figures on the next page. The windscreen wiper motor gives a good constant period to create the waves necessary for the experiments. Once the motor is screwed in place and working at about 6 volts, add sand and water.
2. You could build a wave tank using plastic or timber and have a manual paddle or you could even use a stream tray supplied to schools to show how streams flow. However, these have limited use as you need a side-on view.
3. Set the wave tank in operation to give slow small waves.
4. With a ruler, measure the wave length by working with a partner and, using a marking pen, mark off accurately two crests on the front of the tank.
5. Count the number of crests that pass a fixed point in 10 or 20 seconds and calculate the frequency in waves per second.
6. Now calculate the wave celerity using the formula as outlined in your textbook - *Marine Science for Australian Students, page 40*.
7. Fill the tank with sand to make a beach, gutter and offshore storm bar as shown in Figure 15.1. The distance between the top of the storm bar and the water level in the tank is critical. Some experimentation may be needed to move the sand forward, but should lie between the 20 - 50 mm range.
8. Start the wave paddle to create the effect as shown in Figure 15.2. Make a careful analysis of how the sand moves. As the waves move towards the beach the orbit fields start to interact with the sand and shape it into a beach profile.

### Materials and equipment (per group)

#### Equipment required

- wave tank (see Figures page opposite)
- 12V battery charger
- old windscreen wiper motor
- friendly Manual Arts Teacher or parent

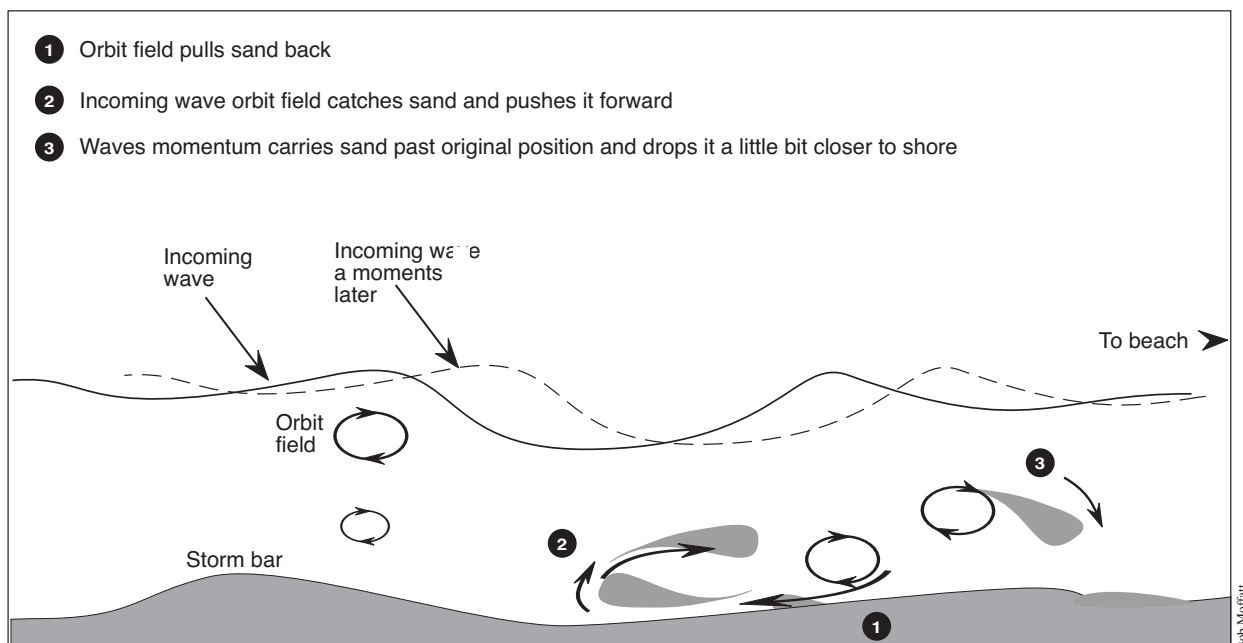


Figure 128.1 As small frequent waves move towards the beach, the orbit fields interact with the storm bar moving the sand slowly towards the shore.



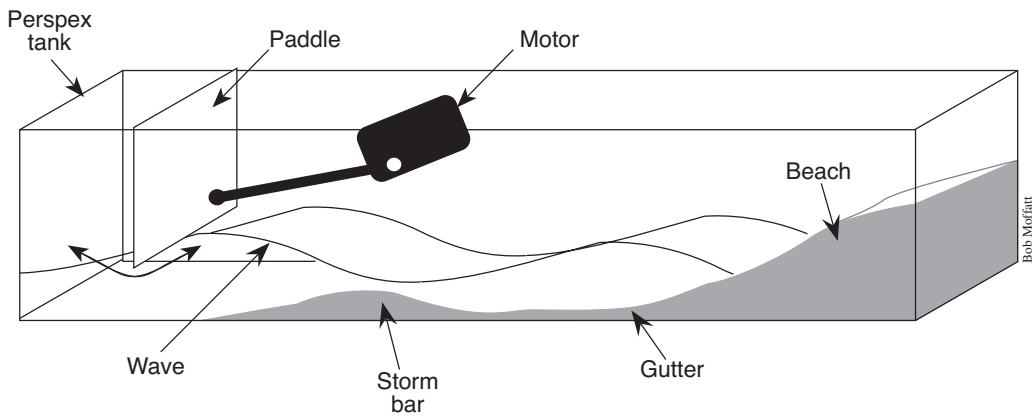


Figure 129.1 Orbit field setup

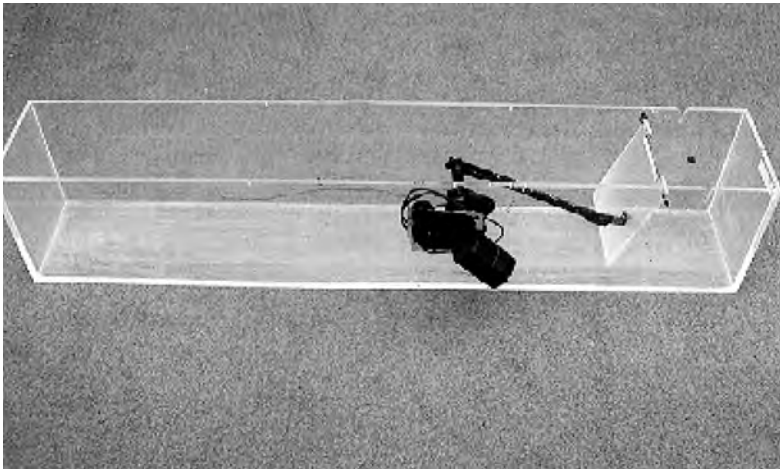


Figure 129.2 Wave tank made in industrial arts department

**Questions**

Q1. Estimate if the wavelengths are different for the different paddle speeds.

---



---

Q2. Experiment if the frequency increases or decreases with different wavelength. Report your results.

---



---

Q3. Compare celerity with wavelength.

---



---

Q4. If the wave tank is run for any length of time, describe if the sand at the bottom of the tank moves. If so, in which direction and under what wave conditions?

---



---

Q5. Derive a formula for the conditions under which waves break.

---



---

Q6. Suggest who might use such calculations and for what purpose.

---



---

# Appendix 4 Classroom activities

## 4.1 The active beach system

Based on an original exercise by Gwen Connolly, St. Augustine's College

### Method

1. Read the instructions to the three level guide in Figure 130.1.
2. Now read the article on the page opposite, then complete the following:

#### **Level 1 Literal — reading for accuracy**

- a. For each of the following statements write T (true) or F (false) in the space just after the number.
- b. Be able to show where these statements appear in the article.
- c. Use P for paragraph and L for line.
  1. \_\_\_\_ Beaches are made of sand from the erosion of rocks.
  2. \_\_\_\_ A sand budget is only governed by the prevailing winds, tides and currents.
  3. \_\_\_\_ Small broken waves predominately control the sand build up on the beach.
  4. \_\_\_\_ Bores drop their sand in a small ridge known as a berm.
  5. \_\_\_\_ During storms, wave bores, drag the sand offshore to form a sand bar.
  6. \_\_\_\_ A groyne is a preventative measure against weathering.

#### **Level 2 Interpretive — drawing conclusions**

1. \_\_\_\_ Estuaries and bays act as sinks where sand is stored for later movement along the beach.
2. \_\_\_\_ Bays are areas of sand collection due to the bending of waves around headlands.
3. \_\_\_\_ A beach will not erode during a storm if the waves are absorbed by the storm bar.

#### **Level 3 Applied — defending your opinion**

Be able to give reasons (argue) why your answer is correct.

You may draw on additional information from other sources.

1. \_\_\_\_ Beach conservation groups should be more active in your local area.
2. \_\_\_\_ Developers should be allowed to build on the waterfront.

### THE THREE LEVEL GUIDE

A three level guide is used to impart important information. Teachers believe that in doing work and having to justify your answer, students are more likely to remember it.

The following rules are important to make this work.

1. Absolute silence for 10 – 15 minutes during which time you are to read the article and answer True (T) or False (F) to the statements in the method section.

You also need to justify your answer by referring to the article, e.g. P3L2 — paragraph 3 line 2 or F10.2 — Figure 137.1

2. The class is then divided up into groups of four students and you have 15 minutes to discuss your answers and arrive at a group set of answers. Make sure that democratic discussion occurs and that the group is not dominated by one or two people.
3. Finally re-group and as a class discuss the article.



Figure 130.1 The three level guide

## Beach composition

Beaches are made of sand. The sand comes from the erosion of rocks and has been washed down to the sea over many years to form the sand budget.

The sand budget moves in a sand system which is governed by the shape of the coastline, prevailing winds, tides and currents. Sand is added to the system at one end, creeps along the coastline and is lost at the other. Estuaries and bays can act as sinks or places where the sand is lost. Moreton Bay in Queensland is a sink which absorbs the sand as it flows north.

## Beach building

Small waves are the predominant force that controls the sand buildup on the beach. As a small wave breaks, it forces the sand up off the sea-bed. The broken wave is called a wave bore as shown in Figure A.

This bore carries the sand towards the beach. There are many bores at a time and the net movement is towards the beach.

When the bore stops it loses its energy and drops this sand in a micro-ridge that can be seen on the beach. Some sand runs back, but more bores overtake the sand moving back with the net result of sand staying in the swash zone.

As the tide goes out these microridges dry and wind blows the sand up the beach into the dunes.

Sand also moves along the coast in a longshore drift current. The current moves the sand because the waves break on the beach at an angle. Where headlands occur, waves bend around and slow down dropping their sand.

## Beach erosion and rebuilding

Larger waves formed during storms break down the beach as shown in Figure B below. Initially they erode the beach face dragging sand out to sea. The wave bores are very long and drag the sand offshore to a storm bar. The sand runs back forming runnels. There are not enough wave bores to keep the sand there.

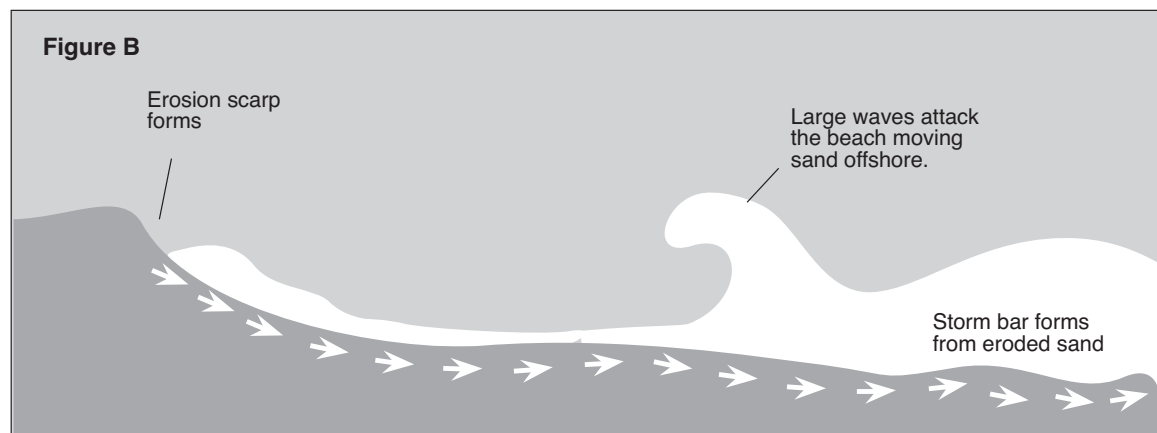
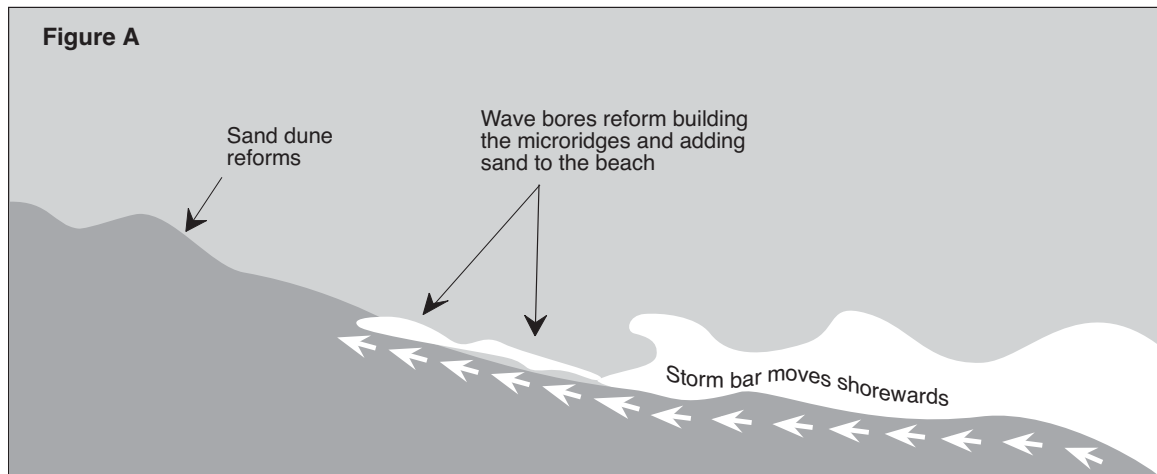
The beach keeps eroding till the forces of the storm waves can be absorbed on the storm bar.

When the waves get smaller, the sand moves towards the beach again pushed by the wave bores.

## Beach conservation

Some preventative measures have been offshore breakwaters, rock boulder walls, groynes, dumping sand on the beach by trucks or pumping it from offshore (or creeks and rivers). Dune fencing and the planting of beach trees and shrubs have also been part of prevention programs. These measures are all designed to maintain beach levels.

Beach conservation involves the establishment of a program (often long term) that will allow natural movement of sand while maintaining the natural sand budget. It is necessary for tourism, but also needs to provide aspects of the natural world which are necessary to maintain nature's balance. Conservation intends to maintain a balance in nature in terms of human habitation, e.g. protection of beach front sand, maintaining beaches for locals and tourists.



Bob Moffatt

## 4.2 Management of longshore drift

Based on an original exercise by Gwen Connolly, St. Augustine's College

### Method

Read the instructions to the three level guide in the box opposite. Now read the article in Figure 132.1 and complete the following:

#### Level 1 *Literal — reading for accuracy*

- a. For each of the following statements write T (true) or F (false) in the space just after the number.
  - b. Be able to show where these statements appear in the article.
  - c. Use P for paragraph and L for line.
1. \_\_\_ The Nerang River used to enter the sea much further south of its present location.
  2. \_\_\_ The Southport Yacht Club frequently hosts open sea races.
  3. \_\_\_ The Federal government decided to 'train' the river entrance by the use of rock walls.
  4. \_\_\_ The northerly movement of sand gets trapped by the seaway wall.
  5. \_\_\_ The sand bypass system collects sand and pumps it under high pressure under the seaway.
  6. \_\_\_ Wavebreak island was established to trap sand that leaves the river and to stop waves from reaching the foreshore.
  7. \_\_\_ Sand bypassing ensured no delta is formed at the river mouth.

#### Level 2 *Interpretive — drawing conclusions*

Be able to show why you arrived at the following conclusions with evidence from the article.

### THE THREE LEVEL GUIDE

A three level guide is used to impart important information. Teachers believe that in doing work and having to justify your answer, students are more likely to remember it.

The following rules are important to make this work.

1. Absolute silence for 10 – 15 minutes during which time you are to read the article and answer True (T) or False (F) to the statements in the method section.

You also need to justify your answer by referring to the article, e.g. P3L2 — paragraph 3 line 2 or F10.2 — Figure 137.1

2. The class is then divided up into groups of four students and you have 15 minutes to discuss your answers and arrive at a group set of answers. Make sure that democratic discussion occurs and that the group is not dominated by one or two people.
3. Finally, re-group and as a class discuss the article.

1. \_\_\_ The establishment of the Gold Coast Seaway has prevented loss of life and vessels.
2. \_\_\_ Sand no longer gets trapped on the southern side of the seaway.
3. \_\_\_ Other problems have been created by the construction of the seaway.
4. \_\_\_ Animals and plants suffer when sand bypassing is used.

#### Level 3 *Applied — defending your opinion*

Be able to give reasons (argue) why your answer is correct. You may draw on additional information from other sources to justify your answer.

1. \_\_\_ Construction of a seaway is a necessary evil.
2. \_\_\_ Conservation groups should be consulted when planning to build a seaway.

### Case study

The Nerang River in Queensland lies at the northern end of the Gold Coast. Over the years, the river entered the sea much further south and progressively moved northwards from the late 1900's. This is a feature of river systems which are affected by a northerly movement of sand.

The bar at Southport had become dangerous for boats and trawlers. The Southport Yacht Club had never had an open sea race because they could not get their boats out. Many accidents were occurring on the bar with loss of life and valuable investments. The local government in association with state and other consultancy authorities decided to 'train' the river entrance by the use of rock walls. It was realised that a system of sand bypassing had to occur so that the natural northerly flow of sand would not block the river mouth and prevent the other beaches north of the wall from eroding.

What was called for was a system which could take the sand from one side of the training walls to the other without forming a delta. This system is called a sand bypass system because it bypasses the river mouth. The one built at the Nerang River

mouth takes the sand from one side to the other before it has time to build a delta. Sand therefore cannot enter the river and silt the mouth. Boats can keep using the seaway in all weather and the sand can continue north thus stopping erosion on the other side.

Since the establishment of the bypass system in 1986, considerable sand has been pumped northwards. Problems have occurred in the jet pumps because sand is a very abrasive mixture. Wave Break Island has developed into a fully vegetated sand island with casuarinas and sand spinnifex in abundance.

The river mouth has become deeper and the tide levels have changed in the river. More sand is exposed during low tide creating problems with breeding grounds for animals and plants. Currents have increased at the river mouth and more people enter and leave the bar adding to the local rescue problems. On the whole the seaway has been a success and will be closely watched as a fore-runner to other engineering feats.

The effect of this sand bypassing system is shown on the page opposite.

Figure 132.1

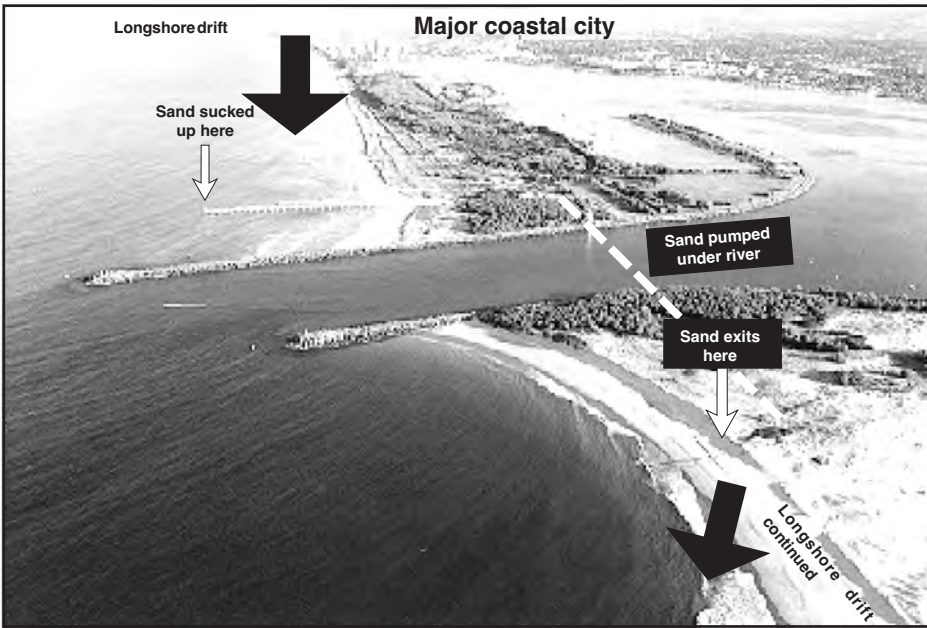


Figure 133.1 Longshore drift and the Nerang River entrance

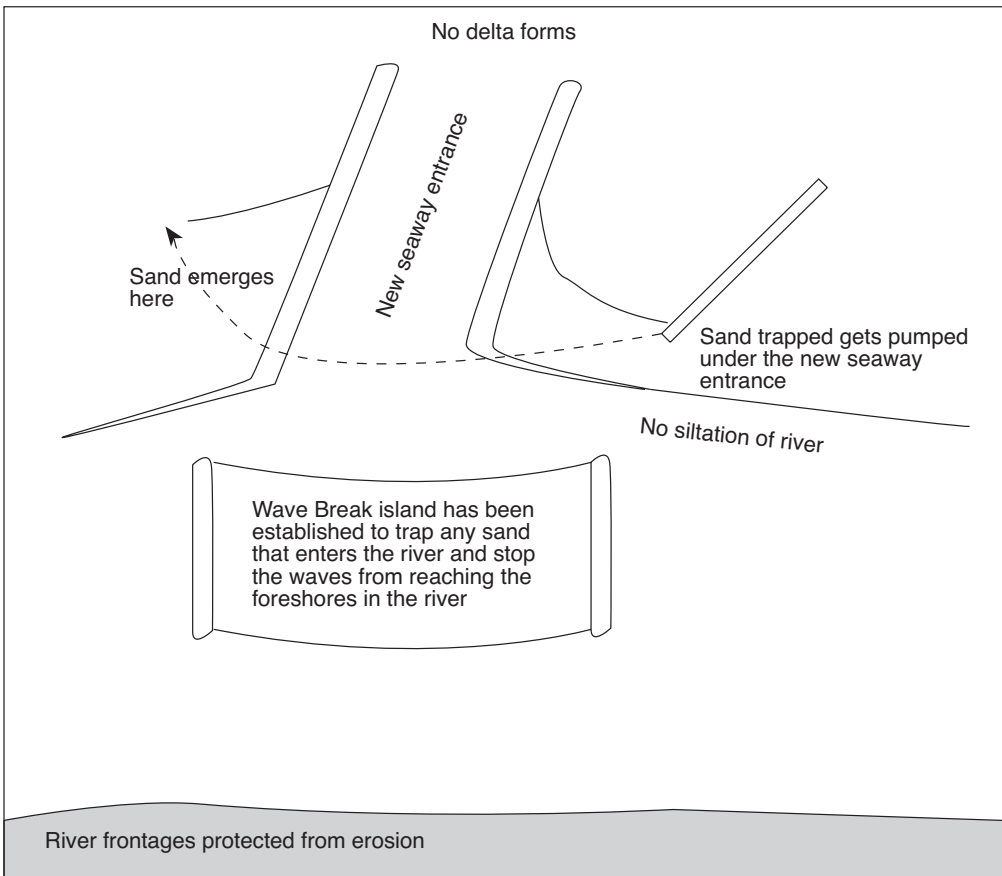


Figure 133.2 The sand bypassing system

### 4.3 Model ocean and coastline bathymetry

Use the templates on pages 137 - 142 to make other models using the same method.

#### Method

In this activity you will construct a model, as shown in Figure 134.1, from a template as shown on the page opposite.

1. Look carefully at the figure on the page opposite and note the different depths marked out by the bathymetric lines 4, 6, 8, 10, 20 and 30 metres respectively.  
See which contour lines are above and below water level. Above sea level is positive and below is negative.
2. Cut out a piece of A4 cardboard, write 40 m on it and place it to one side.
3. Place a piece of carbon paper between a copy of the template (Figure 134.1) and a piece of A4 cardboard. Make sure the carbon is arranged so that a copy will be made onto the cardboard sheet.
4. Look at the Hypothetical Bay template and find the 30 m bathymetric line. You will see outside the margin the letters A1, A2, B2, C, D, E, F, and B1. The letters D and C will be at the top corners of the page and E and F at the bottom corners.

Starting with point A1, trace over the points from A1 along the 30 m bathymetric line to A2. Then keep tracing through the points C, D, E, F until you get back to A1 with your pen. Remove the template and carbon paper and you should see the 30 m depth traced out.

Use scissors or a paper cutting pen to cut this shape and use the glue to stick this onto the 40 m depth you placed to one side.

5. Place the carbon paper again behind the template and another piece of A4 cardboard.  
Find the 20 m bathymetric line and trace over the points B1, 20 B2, C, D, E, F and back to B1.
6. Use scissors or paper knife to cut out this shape and glue it over the 30 metre depth cardboard sheet.
7. Now repeat for each of the depths to make up your model of Hypothetical Bay.

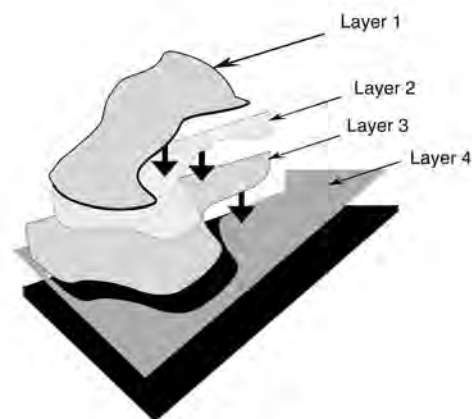


Figure 134.1 How the various layers are added to make up the model

Bob Moffatt

#### Questions

Write your answers on the sheet provided.

- Q1. Match the names of the following places with your model (use Hypothetical Bay names supplied):
- Evans Head, Halpin Hill, Jensen River, Maloney Bay, Perry Shoals, Mt. James, Lynch River, Heyer River, Wiley Island, Sumpter Island, Maclean Reef, Rogers Reef, Col's Reef, Tony's Wreck Reef, Langley Reef, O'Connor Reef, McGarvie Point, Tulip Inlet, Watson Swamp, Claridge Inlet, Moffatt Headland, Coleman's Reef, Critchley Peak, Pitman Point, Townsend Bay, Kaigan Point, Steggle's Beach, Surfrider Bay.
- Q2. As a tourist operator you have to identify places where tourists will have a great time. Weather and sea conditions are important. For each of the following, mark in where you would advise a family to go if they wanted to have a great day out.
- a. It is blowing 20 knots from the north and the children want to go for a surf with their body boards.
  - b. Grandma and grandpa want to do a bit of quiet fishing. It is raining and overcast with a 10 m south easterly swell.
  - c. A group wishes to study a mangrove swamp in the morning and then climb a peak on an offshore island in the afternoon.
  - d. A group wants to go deep sea fishing. The weather is fine with a 1 metre sea from the east.
  - e. A dive group wants a reef with great visibility. It is fine with a 10 knot westerly.
  - f. A surf contest is planned where spectators can see surfers ride two metre waves.

#### Materials and equipment (per group)

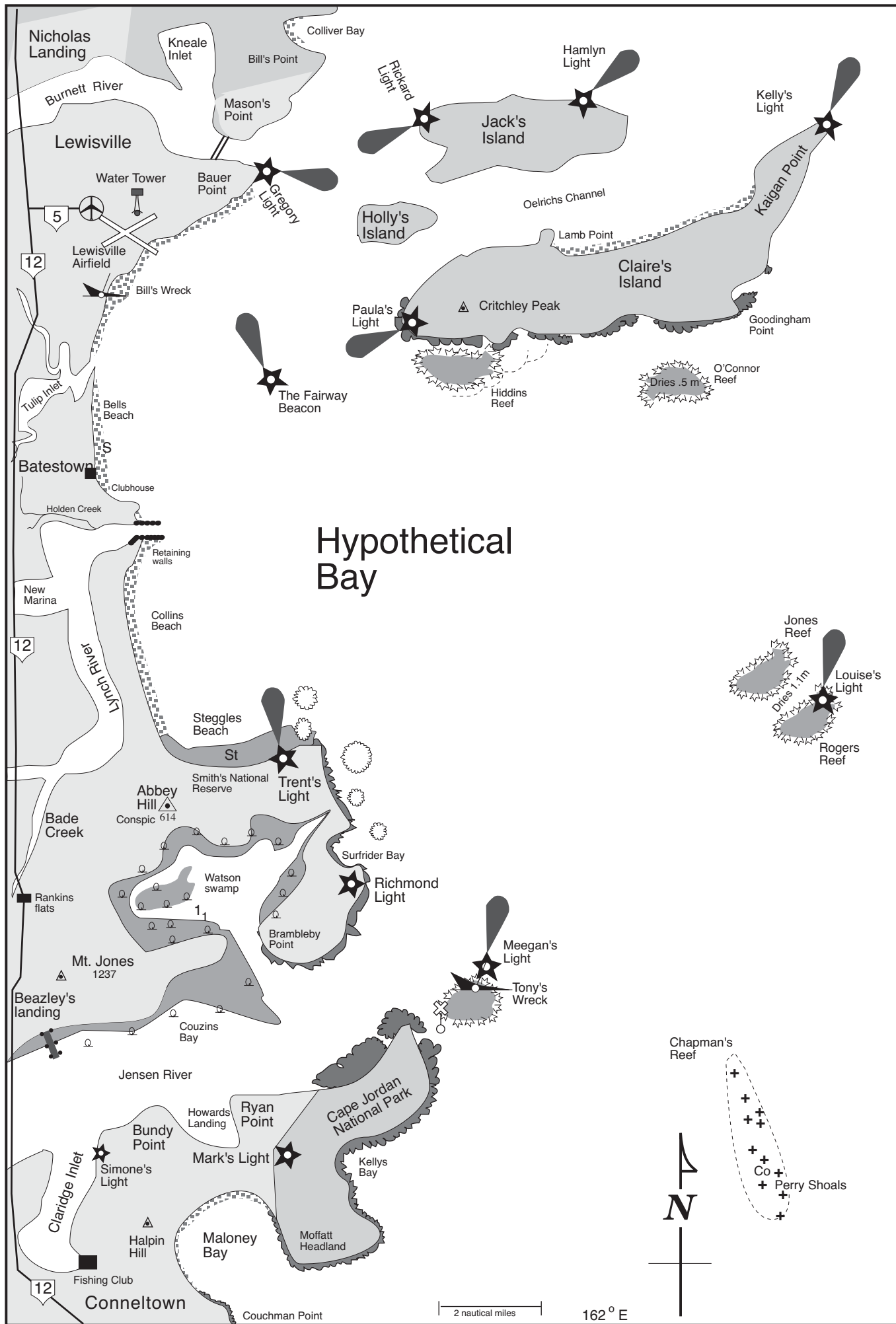
##### Equipment required

- 6 pieces of A4 crinkle cardboard
- carbon paper and glue
- paper artist's cutting knife
- copy of Hypothetical Bay template

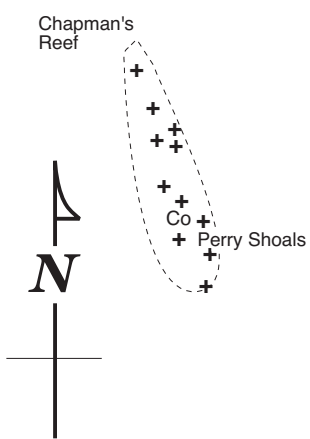


Figure 135.1 Hypothetical Bay template.

Bob Moffatt



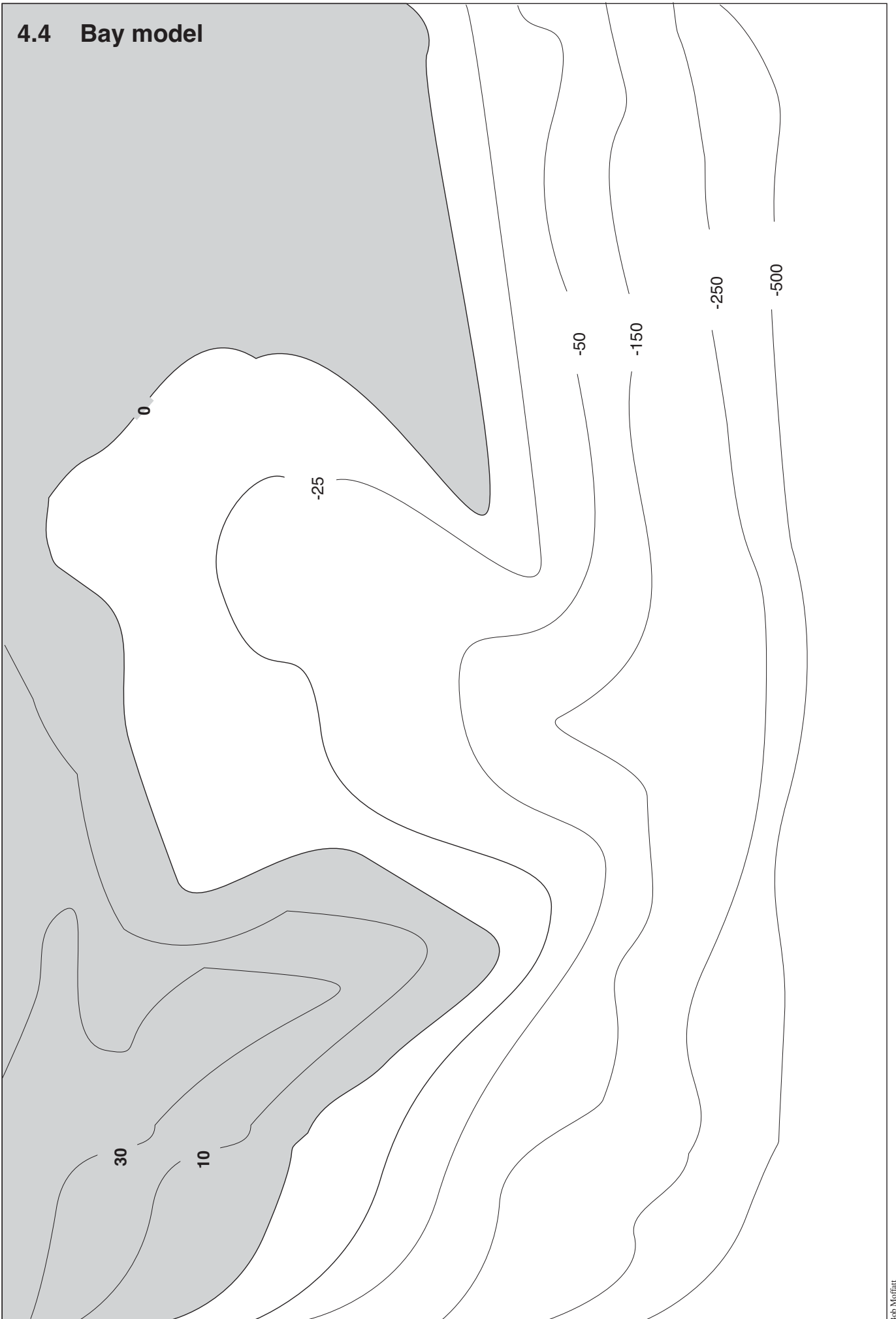
# Hypothetical Bay



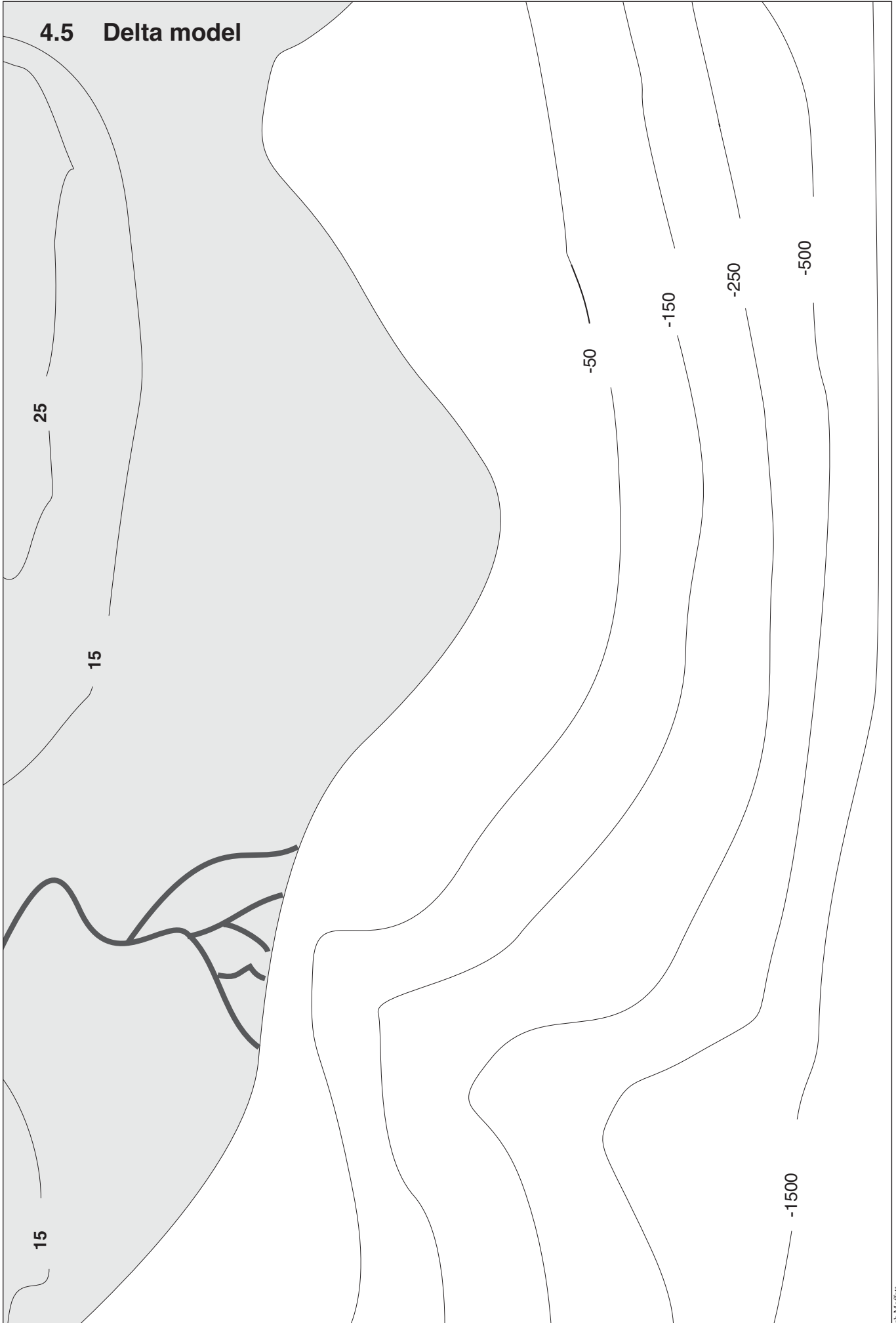
Bob Moffatt



## 4.4 Bay model

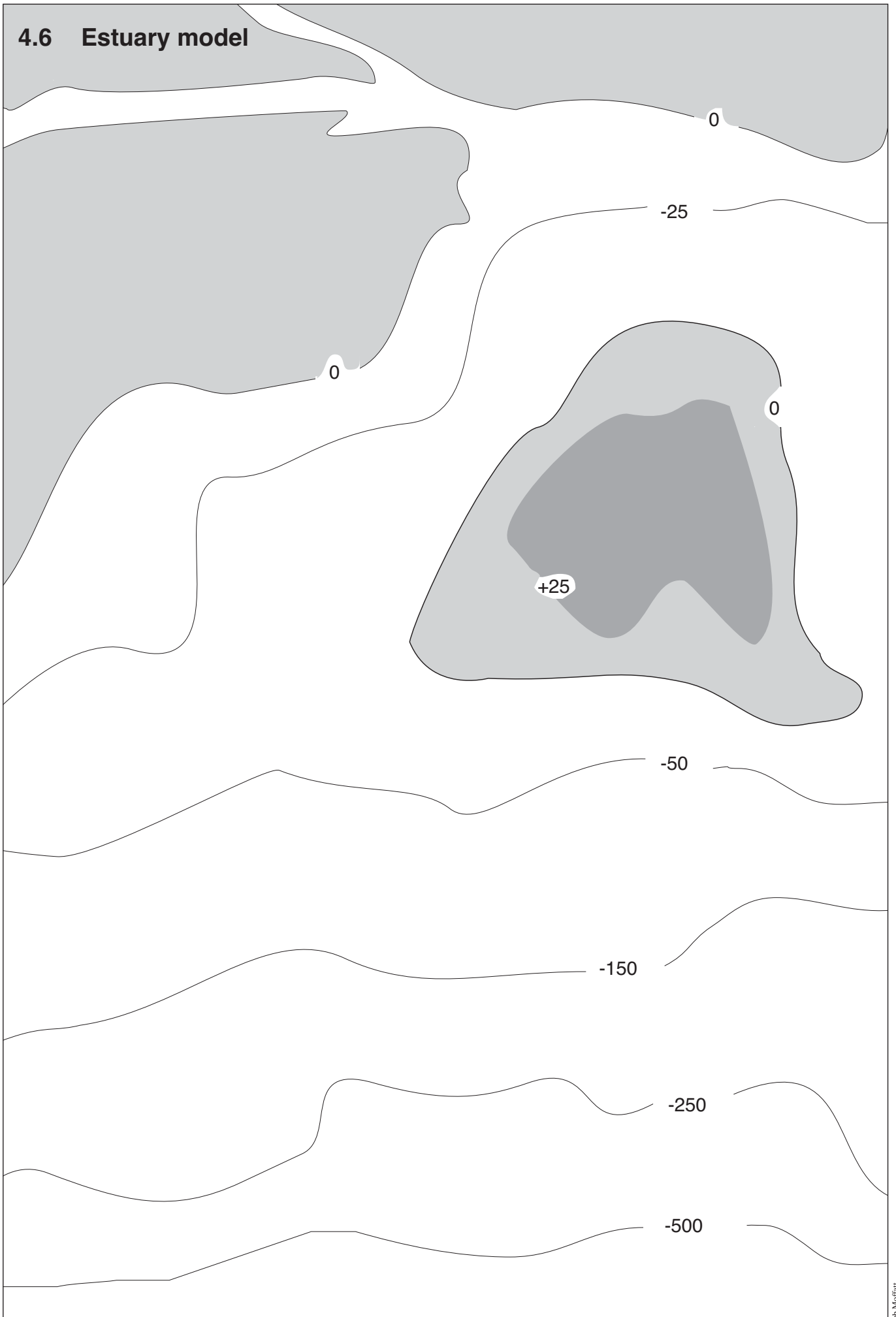


# 4.5 Delta model



Bob Moffatt

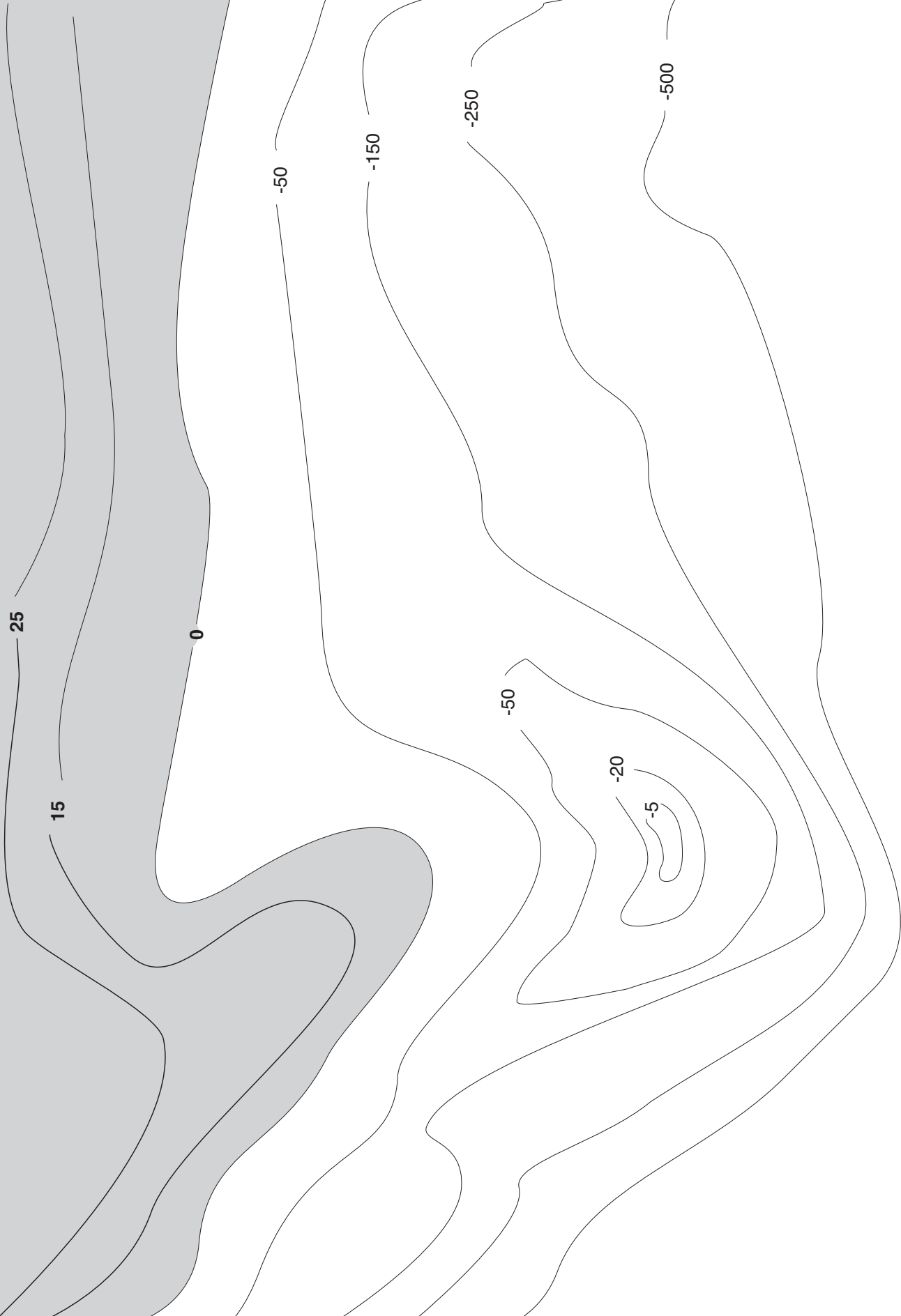
## 4.6 Estuary model



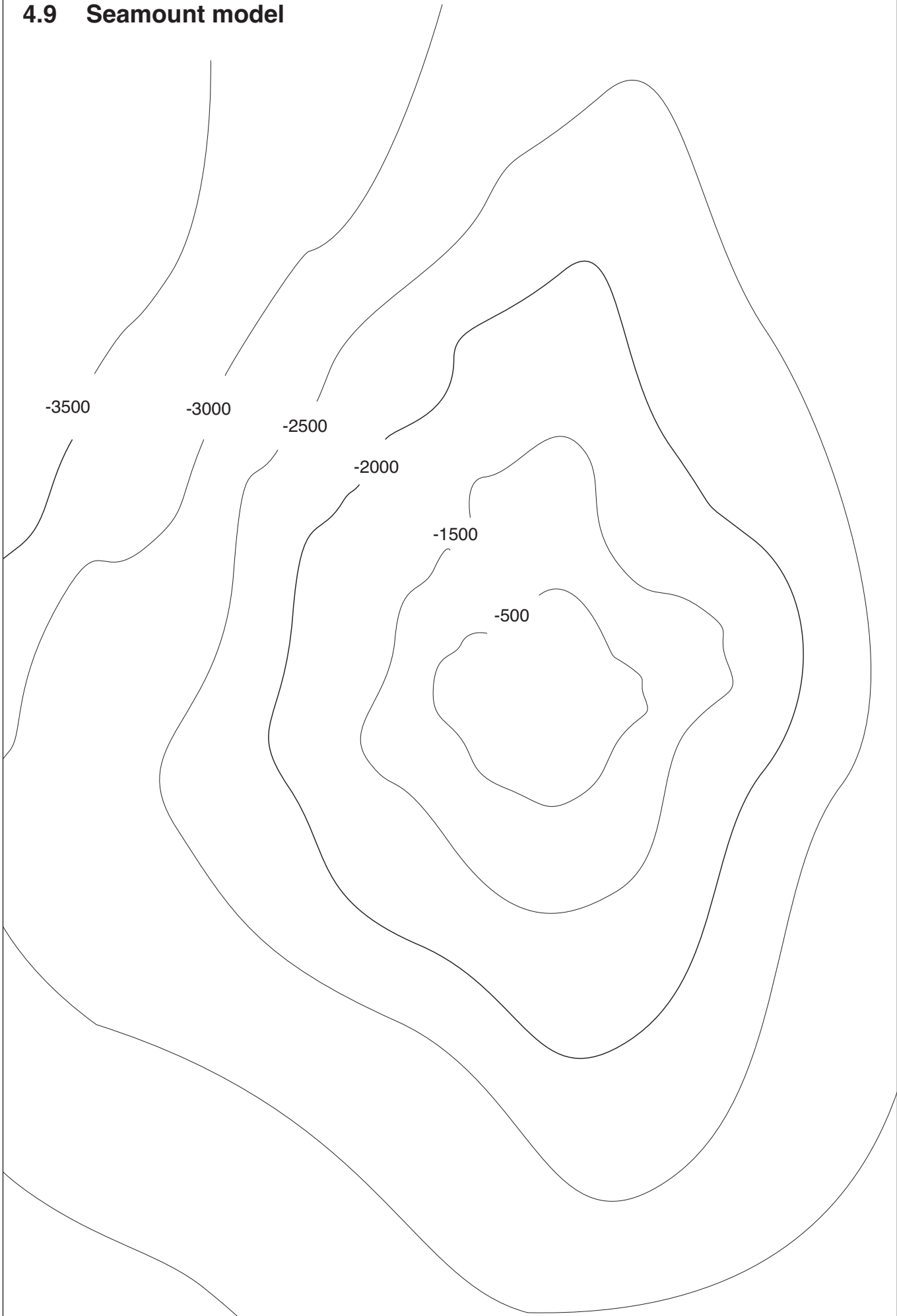
# 4.7 Offshore island model



# 4.8 Headland model



## 4.9 Seamount model



## 4.10 Practice essay on beach erosion

Based on original exercise by Gwen Connolly.

### Method

There is some concern about the stability of some of our beaches.

Some have erosion problems while others seem to be relatively stable.

Select one local beach and explain its present problems and how these problems are being overcome.

Then conclude your essay by recommending how protection of your beach can be achieved in the future.

1. Use the guide to construct a draft copy first, then write your final essay.
2. Both the draft copy and the final essay are to be submitted. (Show your teacher your draft copy before writing your final copy.)
3. Information for this exercise would come from:
  - a. class work
  - b. field trip to beaches
  - c. library information on your local beach

### Guide for draft copy

Name and describe the problem in general terms.

What effects does it have on the natural environment? Describe the problem in the specific location that you have chosen.

What were the causes of the problem at this location?

Write a paragraph for each cause; tell of its effect on the environment (problem); describe the solutions which have been used to counteract this problem.

Put these causes-effect paragraphs with the attempted solutions in correct sequence.

Cause

↓

Effect (problem)

↓

Solution/s (preventative action)

↓

Next effect (pattern)

↓

Solution/s

↓

Resulted in

↓

Next effect

↓

Solution

*Describe the location at present*

Which solutions have been the most effective and why?

*Conclusion*

Recommend effective prevention for the future (from evidence given in your essay).

## 4.11 Currents around Australia and New Zealand

### Questions

Use an atlas and your *Marine Science for Australian Students* textbook to answer the following questions.

Q1. Mark the following places on the figure opposite:

Cape York, Perth, Sydney, Darwin, Broome, Carnarvon, Albany, Esperance, Port Lincoln, Adelaide, Kangaroo Is, Melbourne, Port Campbell, Launceston, Hobart, Dunedon, Christchurch, Auckland, Wellington, Port Macquarie, Brisbane, Townsville, Thursday Island, Port Moresby, Timor.

Q2. Use the information sheet and your textbook to name the currents 1 - 6 around Australia in Figure 145.1 and name the cities and towns identified in Question 1 that they pass.

Q3. Use the information sheet to answer the next three questions.

a. The Coral Sea is almost a metre 'higher' than the Tasman Sea. Explain what this causes.

---

---

---

b. In winter, the Tasman Sea cools at the surface. Explain how this occurs.

---

---

---

c. Explain the term EAC and who made it famous.

---

---

---

d. Describe how eddies form.

---

---

---

### Extension web sites

Try looking up these WWW. references

<http://seawifs.gsfc.nasa.gov>

<http://www.pmel.noaa.gov>

<http://nic.fb4.noaa.gov>

<http://www.marine.csiro.au>

#### Materials and equipment (per group)

#### Equipment required

- Access to computer, modem and internet.

#### Information sheet

<http://www.marine.csiro.au/LeafletsFolder/oceanresearchleaflet.html>

Download information sheet No 3, on the East Australian Current by George Cresswell from CSIRO Division of Oceanography





Bob Moffat

Figure 145.1 Australia, PNG, Timor and New Zealand



Bob Moffat

Figure 145.2 Australian and NZ currents (CSIRO)

## 4.12 Forces that cause ocean water to move

### Questions

Use your textbook - *Marine Science for Australian Students* to answer the following questions.

- Q1. Match the statements in the table in Figure 147.2 with the corresponding numbers above the illustrations of Figure 147.1.
- Q2. Explain the difference between a rising sea and a developed swell.
- 
- 
- 
- Q3. Study the weather map in Figure 146.1 and calculate the size of the fetch that would be generating waves for Sydney, Perth and Brisbane.
- 
- 
- Q4. Name the types of waves tides generate. Give an example of how a tide can generate a wave.
- 
- Q5. Explain the term *gyre*.
- 
- 
- Q6. Define the term coriolis force and how it affects currents.
- 
- 
- Q7. Explain the term *Ekman spiral*.
- 
- 
- Q8. Determine what type of wave an undersea earthquake can generate.
- 

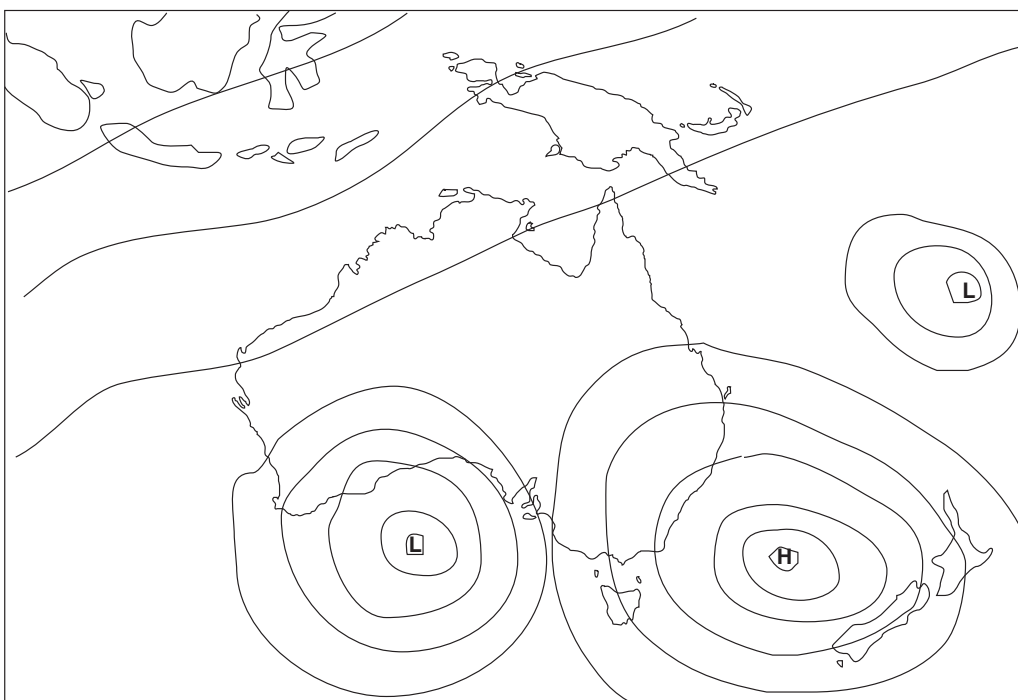


Figure 146.1 Weather map

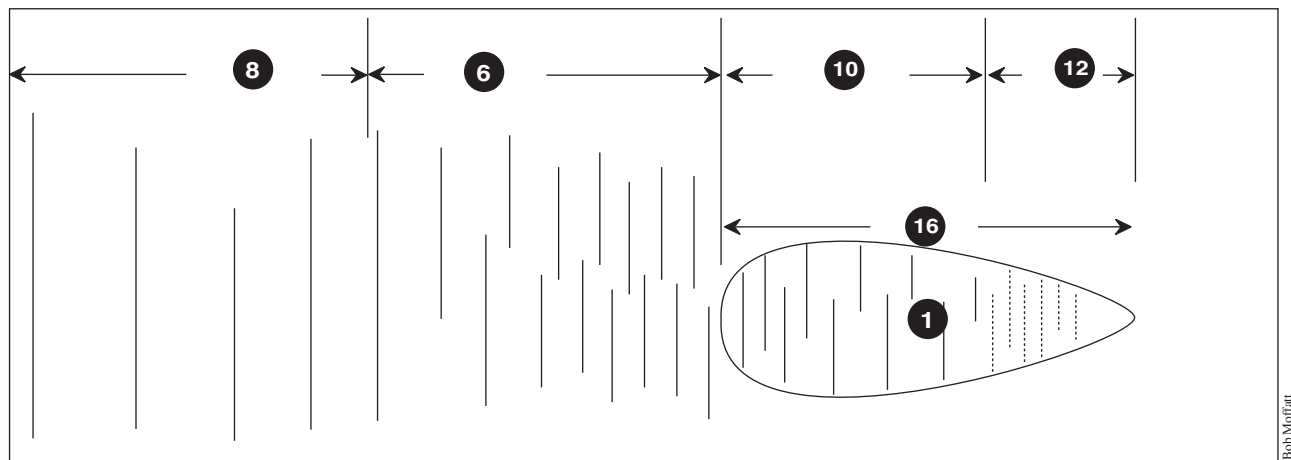
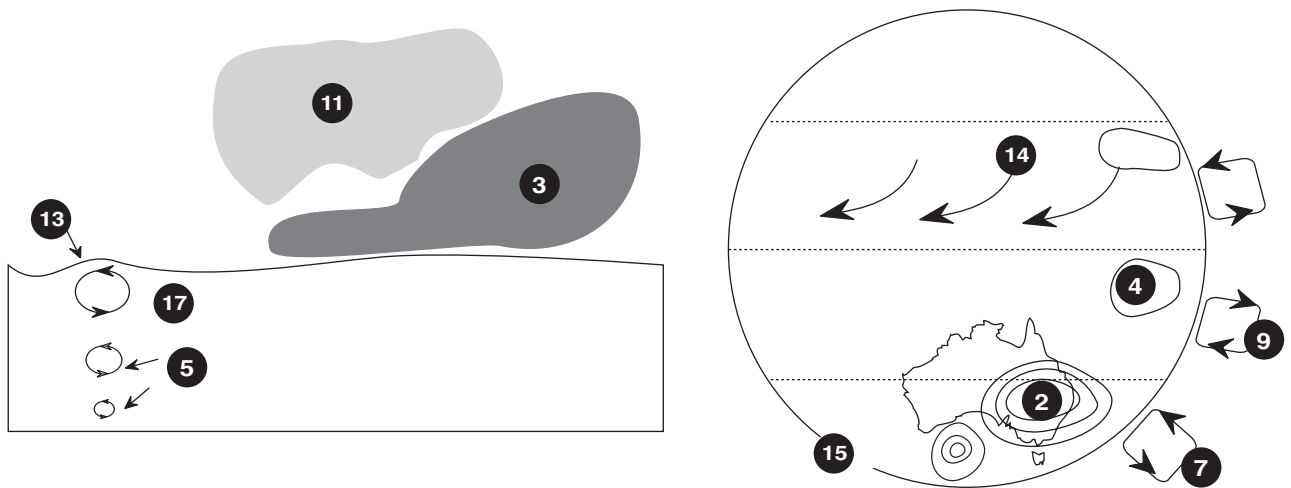


Figure 147.1 Illustration for question 1

Statement	Matching number
A circular motion is set up, called a wave orbit.	
The water in the orbit moves in a circular motion while the energy in the wave moves on.	
Ripples.	
The sun causes hot air to rise.	
Fully developed swell.	
Wind makes ripples.	
Hot air rises.	
Water under the wave moves in a circle.	
North East Trades.	
Rising sea.	
Cool air falls creating high pressure systems.	
Low pressure system — L.	
High pressure system — H.	
Hot air rises creating low pressure systems.	
Fetch.	
Wind.	

Figure 147.2 Table for question 1

## 4.13 Ballast water problems

Acknowledgement is given to the Australian Fisheries Management Authority for permission to reproduce the article from Australian Fisheries, October 1992.

### Questions

Read the article opposite and answer the questions below.

Q1. Recall the scientific name for the northern hemisphere starfish.

---

Q2. Suggest how this starfish may have been transported to Tasmania.

---

Q3. It is stated that '*Astereas amurensis*' is a voracious species. Explain the meaning of this term.

---

Q4. Predict the effect of this species on aquaculture, other fisheries and the marine environment.

---

Q5. Identify which group or phylum starfish belong.

---

Q6. Define the term 'exotic species' from the way the term is used in the article.

---

Q7. Name where and when the first confirmed recording of '*Asterias amurensis*' was in Tasmania.

---

Q8. Distinguish the species '*Asterias amurensis*' from other starfish.

---

Q9. The article suggest that governments should spend more money completing base line surveys of material fauna. Explain how this would help in the battle against exotic species.

---

Q10. Define the job description of a taxonomist. Suggest why does the article calls for more taxonomists.

---

Q11. Discuss the biology of the species '*Asterias amurensis*'. Include its habitat, diet etc.

---

Q12. Predict if the species '*Asterias amurensis*' will eventually threaten the scallop industries in Queensland. Give one reason for your answer.

---

Q13. Suggest steps needed to be taken to evaluate the magnitude of the problem.

---

Q14. Suggest possible methods to control the population of '*Asterias amurensis*'.

---

Q15. Outline the measures governments need to take to stop the introduction of other exotic species.

---

---

---

## Introduced starfish pose threat to scallops

The recent discovery of a voracious shellfish-eating introduced starfish in Tasmanian waters has aquaculturists and fishermen worried. Wolfgang Zeidler of the South Australian Museum reports on the potential threat of '*Asterias amurensis*' to the fishing industry.

### Ballast water suspected

Many foreign species have been introduced to Australian waters since colonisation. In the early days wooden ships were often heavily fouled thus providing the ideal habitat for the transportation of animals and plants. More recently foreign ships have been releasing large amounts of ballast water in Australian ports with recent estimates of around 58 million tonnes being released each year (Jones, 1991). The potential use for the ballast water to carry exotic marine species is well known and the possible harmful effects of these introductions to our marine environment is of particular concern (Hutching et. al., 1987; Jones, 1991).

Obviously not all exotic species transported by ship's ballast survive but some of those that do could have devastating effects on the marine environment and aquaculture. One such potential threat is the recent introduction of a northern hemisphere starfish, *Asterias amurensis* (Lutken, 1871). Just how this species was introduced is not known for certain but, being relatively common in Japanese waters, it was most likely transported to Tasmania in the ballast water of vessels from Japan.

### Large species can devour scallops

*Asterias amurensis* is a voracious species and a well known predator of scallops and other bivalved molluscs in Japan. Its ability to easily prise open and devour scallops is readily demonstrated in an aquarium. Being a relatively large starfish with an arm length of up to 200 mm it is not difficult to imagine the damage a number of these 'monsters' could do to a scallop bed. However, at this stage, the effect of this species on the aquaculture industry, other fisheries and the general marine environment is not known.

A closely related species *Asterias vulgaris* (Verrill, 1866) has been blamed for the demise of the United

States oyster industry which was extremely viable early this century.

### Distribution and natural history

*Asterias amurensis* occurs naturally in the northern hemisphere ranging from Kamchatka Peninsula (Bering Sea and Sea of Okhotsk) south to Kyushu (Japan) to about 170 m depth.

In Tasmania I first noticed this starfish in early 1991 as it was common in the dock areas of Hobart and around Sandy Bay.

Believing it to be a Tasmanian species unknown to me, I thought no more of it until a colleague Karen Gowlett-Holmes collected a specimen and concluded it was not an Australian species but an exotic one which was relatively common in Japan.

This identification was later confirmed by Loiset Marsh of the Western Australian Museum who is an expert on starfish and other echinoderms.

The first confirmed record of this species in Tasmania is a specimen in the Tasmanian Museum, collected from Rosny Point, Hobart, in October 1986.

More recently it has been recorded in abundance in the Derwent River around Hobart, ranging from just north of Bowen Bridge to Kingston.

It has also been found on the eastern coast at Triabunna, in Mercury Passage and at Promis Bay (Freycinet Peninsula), in each case associated with scallops, and in the Huon River estuaries with one report of it devouring mussels in a mussel farm at Cygnet!

It was not recorded earlier because the first collected specimen had been mis-identified as a relatively common Australian species, *Uniphora granifera* (Lamarck, 1816) (Figures 1 and 2), which it represents superficially. Likewise other zoologists and naturalists assumed it to be this species and took little interest in it, merely noting that it seemed to have increased in numbers recently. This lapse in detecting the introduced species earlier illustrates the importance of having experts on hand to correctly identify species and monitor the marine environment.

*Asterias amurensis* is relatively easy to distinguish from other native starfish by its general appearance (Figures 3 and 4) with larger specimens having slightly fatter arms



Fig 1 *Uniphora granifera*  
— dorsal view

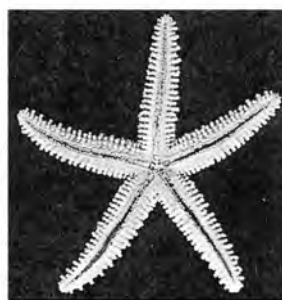


Fig 2 *Uniphora granifera*  
— ventral view



Fig 3 *Asterias amurensis*  
— dorsal view



Fig 4 *Asterias amurensis*  
— ventral view

Australian Fisheries

Figure 149.1 Introduced starfish article (From Australian Fisheries, copyright , October 1992, Reproduced with permission)

(Figure 5). It can be further distinguished from similar Australian species by the four rows of tube feet on the underside of the arms and by the shape of the spines which are not pointed but semi-circular and chisel-shaped. The colour varies considerably from light brown to yellow or orange, often tinted with violet (Figure 6).

According to Fisher (1930) the species can be very prolific and can be found on a variety of substrates ranging from stones and pebbles to 'sticky soft green mud'. Fisher also gives a temperature range of (0.1 – 7.5 °C) but notes later that the latter might be a few degrees too high! Similarly Hayashi (1973) noted that *A. amurensis* in southern Japan inhabited deeper water than in the north and that: 'in the same region the sea-star seems to be obtained from shallower waters in the winter than in the summer'. He concluded that: 'the vertical and horizontal distribution of the species may be greatly influenced by the temperature of the sea water'. It thus appears that *A. amurensis* is a cold water species.

Just what range in temperature the Tasmanian specimens can tolerate is not known but if they prefer cold waters then the species may be restricted to Tasmania.

### Knowledge, monitoring and control

It is most important to first establish the current distribution of *Asterias amurensis* in Tasmanian waters so that the extent of the infestation can be determined. It would also be useful to know the depth range and density of the animals and the temperature of the water they inhabit. The Tasmanian Museum and Art Gallery (TMAG) has produced an informative leaflet to help gather this information. If anyone thinks they have seen this starfish in places other than those mentioned here they should contact the Zoology Department, Tasmanian Museum, 40 Macquarie St, Hobart 7000, preferably with a specimen so that the identity can be confirmed.

The TMAG through this information leaflet and general publicity has alerted the Tasmanian fishing and aquaculture community to this potential threat and is extending its message to the mainland community. The possibility that the starfish may occur in mainland waters cannot be overlooked, particularly in colder waters.

Regardless of what, if any, control methods are adopted, it will be necessary to regularly monitor selected populations of this starfish to ensure that it does not become a threat to the marine environment and hence the fishing industry.

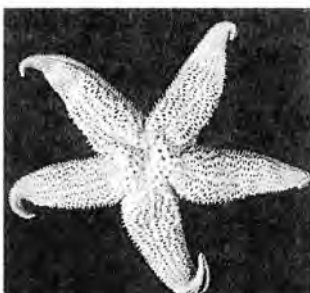


Fig 5 *Asterias amurensis*



Fig 6 *Asterias amurensis*

Australian Fisheries

### A concern for governments

The introduction of exotic species to Australian waters should be of particular concern to federal and State Governments and the fishing industry. It highlights the following.

- The need for stricter controls on the release of ship's ballast water and other means of passage for exotic species.
- The need for base-line surveys to determine the natural fauna of an area so that the effect of introductions can be determined. This would also identify any introduced species that have not yet been recorded.
- The need to monitor the health of our marine environment by regular follow-up surveys. This sort of data is essential to identify introductions at an early stage and determine the impact of exotic species; it may also alert authorities to other factors effecting the health of the environment such as pollution.
- We have any number of pest control officers employed by various authorities for the terrestrial environment, why not also for the marine environment which is as large or larger and every bit as valuable?
- The need for taxonomists so that species can be quickly and accurately identified. The need for a correct identification becomes immediately obvious when one considers that the scientific name enables the researcher to locate all the literature concerning that species.

A wrong identification of a potential pest will lead to a different data set resulting in control methods which may be inappropriate and could cost millions to rectify. Contrary to popular belief, much of Australia's marine fauna is undescribed and probably new to science, thus compounding the problem of distinguishing native and exotic species. Unfortunately the number of practising taxonomists in Australia and worldwide is declining. Even worse, it is not something that can be rectified quickly as it takes several years to develop the expertise in just one group of animals to enable quick and accurate identifications.

Wolfgang Zeidler is Senior Curator, Marine Invertebrates, at the South Australian Museum.

## 4.14 Drain stencilling

Based on original ideas from Surfrider Foundation (USA and Australia).

### Protocol and PR

Successful drain stencilling campaigns are now underway in Brisbane, Melbourne and Sydney. Local authorities and ministers have given the green light for this community based activity to go ahead.

However use these examples to obtain local council approval before stencilling your local drains.

### Method

1. If you are making your own stencil out of cardboard you do not need to apply quick release agent. Figure 151.2 gives some ideas for stencils.
  - For commercially available stencils (Figure 151.1) you need to apply PVA so that the paint can be cleaned off after use.
2. Some guidelines for promoting good public awareness:
  - Discuss the effectiveness of spraying signs in pollution prone areas.
  - Use paint with a brush in preference to a spray can.
  - If you use a spray can do not spray near cars or places where overspray can cause damage (that's the paint that blows in the wind).
  - Stay as a group, don't take off on your own.
  - Take your time and do a good job. Remember you are not in school/college now and are environmental ambassadors for the community, trying to create awareness to a serious environmental problem.
3. Find an approved piece of roadway and clean off the dirt.
4. If you are using a spray can, spray a little bit first, until you get a feeling of how the spray comes out.
5. When people come up and talk to you, explain that you have council permission and that you are involved with public education of drains.
6. If you haven't already done so, design a stencil or banner that can be used in a public education program.



Figure 151.1 Method - get permission



Figure 151.2 Ideas

### Materials and equipment (per group)

- drain stencil (make your own from cardboard and a paper cutting knife)
- gloves
- 1 can of PVA (poly vinyl alcohol) to help clean the stencils after use. This is the quick release agent used in the fibre glass industry.
- spray paint - at time of publication commercial grade paint was available from Dy-Mark (check yellow pages for local phone numbers)
- yellow linemarking paint with which you could try a roll-on system also

If you are going to design your own stencils then have them approved by your school and local authority before spraying or painting

## 4.15 Attitudes and values

### Method

1. Arrange for someone to make an overhead transparency of the values table opposite.
2. Complete the values study table by yourself.
3. Form a group and collate your data in the column to the right.
4. Elect someone to be class recorder and record the group information on the overhead transparency.

### Questions

Q1. List the values that over 90% of the class all share.

---

---

---

Q2. Offer one suggestion why the class held these value so highly.

---

---

Q3. List the values that less than 10% of the class hold.

---

---

---

---

Q4. Calculate the number of values the class held. Comment on this number.

---

---

---

Q5. Make a summary of the attitude of your class towards the environment.

---

---

---

Q6. Decide if you have a personal conservation code. If so, write it down in the space below. If not give a reason.

---

---

---

---

---

---

---

---

---

---



**Values study table**

<b>Values study</b>		
<b>Place a tick in the space before the sentence if you agree and an X if you don't</b>	<b>Group tally</b>	<b>Class %</b>
<b>Am I a person who...?</b>		
... expects to slide down bare high dunes		
... expects to catch fish with my grandchildren		
... catches lots of fish and sells some privately		
... couldn't care less how polluted the surf got as long as it was good		
... wants to have access to the beach without being charged a fee		
... collects what I like from the beach and foreshores		
... eats, drinks and is merry and leaves all my litter behind		
... likes skindiving in crystal clear water		
... likes launching my boat from a shoreline littered with broken bottles and cans		
... likes to view the coastline from a lookout		
... takes my dog on the beach		
... walks over rocky pools at low tide		
... likes to visit rocky areas to watch birds nesting		
... can't see what all this fuss is about conserving our seas		
... likes to have safety nets or enclosures at swimming beaches		
... at surf beaches, likes board riders and surfers separated		
... buys and consumes food and drink at the beach		
... likes to get to isolated places easily and cheaply		
... expects the car to be parked close to the beach		
... likes parks and changing sheds close to the beach		
... dislikes greenies forcing their attitudes onto people all the time		
... is appalled by people who are cruel to animals		
... expects to have life-savers guarding the beach		
... wants clean water, clean sand, no litter		
... puts litter in bins provided		
... collects cans and bottles from the beach and takes them to recycling bins		
... enjoys playing tape recorders and radios on the beach		
... likes to tear down trees and light fires on the beach		
... does not want to be surrounded by lots of noisy people		
... is in favour of nude beaches		
... likes fishing in estuaries and bays		

Figure 153.1 Values study

## 4.16 Sea rights - three level guide

### QUESTIONS

Read the next page and then complete the following three level guide (See instruction box to the right).

For each of the statements write T (true) or F (false) in the space provided.

#### Level 1 (Literal): Reading for accuracy

Be able to show where these statements appear in the article. Use P for paragraph and L for line.

1. \_\_\_ The claim for the Island of Mer arose out of the refusal of Murray Island people in 1982 to accept a lease over the islands from the Queensland Government.
2. \_\_\_ The Crown acquired 'radical title' (i.e. ultimate control) to land on colonisation, actual ownership and use rights were removed from Aboriginal people parcel by parcel.
3. \_\_\_ Native title to the sea, sea-bed and marine resources has been recognised by courts in England.
4. \_\_\_ There is nothing in the Mabo judgement which would seem to preclude the application of native title principles to the sea-bed.
5. \_\_\_ In October 1990, the Murray Island Council made claim to Sea Rights.
6. \_\_\_ The High Court has now established that the Meriam people of Mer hold a 'native title' to their island under customary law which is recognised under Australian common law.

#### Level 2 (Interpretive): Drawing conclusions

Be able to show why you arrived at this conclusion with evidence from the article.

1. \_\_\_ Sea rights have not yet been settled in court.
2. \_\_\_ Many Aboriginal people regard estuaries, bays and waters immediately adjacent to the shore as being part of their land.
3. \_\_\_ The limited recognition of Aboriginal interests in the sea provided by sea closures under Northern Territory legislation has been shown to be inadequate in achieving harmonious management of the Top End coastal waters.
4. \_\_\_ It now seems unlikely that a 2 km buffer zone alone would have fully protected the legitimate interests of Aboriginal people.
5. \_\_\_ Another term used in dealing with sea rights is customary marine tenure (CMT). What do you think this means?
6. \_\_\_ Native title only applies to Australian indigenous people.

### THE THREE LEVEL GUIDE

A three level guide is used to impart important information. Teachers believe that in doing work and having to justify your answer, students are more likely to remember it.

The following rules are important to make this work.

1. Absolute silence for 10 – 15 minutes during which time you are to read the article and answer True (T) or False (F) to the statements in the method section.

You also need to justify your answer by referring to the article, e.g. P3L2 — paragraph 3 line 2 or F10.2 — Figure 137.1

2. The class is then divided up into groups of four students and you have 15 minutes to discuss your answers and arrive at a group set of answers. Make sure that democratic discussion occurs and that the group is not dominated by one or two people.
3. Finally, re-group and as a class discuss the article.

#### Level 3 (Applied): Defending your opinion

Be able to give reasons (argue) why your answer is correct. You may draw on information from other sources to justify your answer.

1. \_\_\_ Why does a proposed buffer zone fail to recognise the coastal sea as an integral, inseparable part of Aboriginal Country?
2. \_\_\_ The purpose of the Racial Discrimination Act of 1975 was to protect the rights of Aboriginal people. How did the then Queensland Government contravene it?
3. \_\_\_ Why should Aboriginal and Torres Strait Islander people have a right to hunt by traditional methods?

# THE HIGH COURT DECISION

By a 6-1 majority the High Court in 3 June 1992, made a judgement in favour of Mr. Eddie Koiki Mabo and others in their claim against the Queensland Government for recognition of their native title to Mer – one of three islands of the Murray group in eastern Torres Strait. The finding effectively overturned the long held legal doctrine of *terra nullius*, which had maintained that Australia was unoccupied territory prior to 1788.

The claim arose out of the refusal of Murray Island people in 1982 to accept a lease over the islands from the Queensland Government. The Murray Islanders maintained that the Queensland Government was not in a position to grant a lease over the islands since the Murray Islanders themselves were already the owners under customary law. During the ten years of legal proceedings that ensued, the Queensland Government passed new legislation, the *Queensland Coastal Islands Declaratory Act 1985*, which purported to extinguish any native title to the Torres Strait Islands should such a title continue to exist. In a separate High Court action in 1988 the Murray Islanders established that this legislation contravened provisions of the Racial Discrimination Act 1975. The *Queensland Coastal Islands Declaratory Act* was therefore declared invalid and the original claim for recognition of traditional ownership of the Murray Islands proceeded to the High Court.

The High Court has now established that the Meriam people of Mer hold a 'native title' to their island under customary law which is recognised under Australian common law. The court also found that native title could be extinguished by explicit legislative acts, or by removing customary owners from their land, or by otherwise destroying the customary law under which such native title is held. However, as happened in the Murray Island case, attempts to extinguish native title by administrative or legislative means may contravene provisions of the *Racial Discrimination Act 1975*.

The immediate impact of the decision applies only to the land of the island of Mer in the Murray group. The importance of the case nationally rests with the extent to which it may have firstly set a legal precedent, and secondly altered the way in which Aboriginal and Torres Strait Islander people may hitherto expect to interact with governments on land, sea and resource management matters.

The original claim by Mabo and others included a large area of sea territory

surrounding the Murray Island group, including both Commonwealth and Queensland waters and sea-bed. Claims for Commonwealth and Queensland waters were withdrawn as the case proceeded, in part because a Queensland Supreme Court judge determined the customary practices in relation to the ownership and use of fringing reefs were no longer in operation, so that the High Court was only called upon to bring down a decision in respect of the land of the Island of Mer.

As it was made clear during consultations with Meriam people during the inquiry, there was still a determination to proceed with claims on the other two islands and surrounding waters. In October 1993 the Murray Island Council announced its intention to control commercial fishing in waters surrounding the island and indicated that a formal native title sea rights claim would be lodged with the Commonwealth Government in the near future. (See "Sea rights ban hits trawlers," *Courier Mail* 28 October 1993.)

## DIMENSIONS OF THE MABO JUDGEMENT

As has been noted by several legal commentators (e.g. Brennan 1992, Nettheim 1992 and Bartlett 1993) the fundamental implication of the High Court judgement is that British acquisition of sovereignty over Australia and its islands did not in itself bring about a transfer of ownership of the land from the indigenous people to the Crown. Although the Crown acquired 'radical title' (i.e. ultimate control) to land on colonisation, actual ownership and use rights were removed from Aboriginal people parcel by parcel over time as European settlement advanced, as land grants were made and as Aboriginal people were killed, displaced or removed from their traditional estates. Where such events have not happened, and where Aboriginal and Torres Strait Islander people continue to have a relationship to their country based on customary law, then native title may continue to exist and if so is recognised under Australian common law.

Although the Mabo judgement referred only to land, coastal Aboriginal people, as well as the Meriam people and other Torres Strait Islanders who participated in the consultation process, have expressed optimism that their claims to ownership of customary marine estates may also be recognised. This possibility is under active consideration by legal advisers to Aboriginal organisations around the country and was raised during meetings with Commissioners at Broome, Cape Leveque, Maningrida, Cairns, Yarrabah, Gordonvale and Palm Island as well as at formal hearings in Darwin

(Transcript, p. 997). Several native title claims which include extensive areas of sea country have already been lodged in courts in Western Australia and Queensland. (The Utemorrah claim in the King Sound area Western Australia and the Fraser Islander claim in Queensland).

The issue of native title over marine estates following the Mabo decision was the subject of a submission to the Inquiry which concludes that:

'Common law recognition of customary marine tenure is highly likely following the Mabo decision . . . there is nothing in the judgement which would seem to preclude the application of native title principles to the sea-bed. (Ms. Joanna Sutherland 351, p 2)

The likelihood that native title can exist and has persisted in marine environments is supported by many legal commentators, including the Office of General Counsel of the Commonwealth Attorney General's Department. That office has advised the Great Barrier Reef Marine Park Authority that although native title is unlikely to the ownership of the sea, sea-bed or natural resources, claims for native title use rights 'have a good prospect of success.' (Mabo: Implications for The Great Barrier Reef Marine Park . . . Advice from Office of General Counsel the Great Barrier Reef Marine Park Authority, p 13, 20 May 1993)

Professor Richard Bartlett, an expert on native title law in the United States and Canada, has pointed out (Bartlett 1993) that native title to the sea, sea-bed and marine resources has been recognised by courts in Canada, United States and New Zealand. He concludes:

'*Mabo* extends to the sea. There may be problems of proof, but they will be no more onerous than on land. Indeed the difficulties of establishing native title in the off-shore may be less than on land because of the lesser extent of inconsistent grants . . .

Native title at common law protects the traditional relationship of Aboriginal people to their environment. To the extent that the environment includes the sea, it is included within the compass of native title. Australia's arrangements to accommodate the rights of non-Aboriginal and Aboriginal people must recognise native title rights to the sea. (Bartlett 1993, p 17)

The implications of the judgement for particular areas of Australia, and the current status of native title over particular parcels of land or water, are not matters for consideration here. It is essential, however, that any recommendations for improved coastal zone management should take note of the probability that some coastal and marine environments and resources are subjected to native title in common law.'

Figure 155.1 From an article called, "A voice in all places Aboriginal and Torres Strait Islander Interests in Australia's Coastal Zone", by Dr Dermot Smyth which was prepared for the Coastal Zone Inquiry,

## 4.17 Territorial waters and the Australian Fishing Zone

Note: AFZ = Australian Fishing Zone

**Web reference and 2008 map**

[www.daff.gov.au/fisheries](http://www.daff.gov.au/fisheries)

### What to do

1. Mark in Figure 157.1 opposite, the following places.  
Sumatra, Java, Timor, Kalamantan, West Irian, Papua New Guinea, Cocos Is, Christmas Is, Australia, New Zealand, Antarctica, Lord Howe Is, Norfolk Is, Kermadec Is, Chatham Is, Macquarie Is.
2. Use coloured pencils to distinguish between the AFZ of Australia and New Zealand.
3. Draw lines in coloured ink to show the territorial waters of Australia and New Zealand.
4. By counting in squares, calculate the percentage of land and sea for Australia and New Zealand and record your data in the table below.

Australia		New Zealand	
Number of squares occupied by land	=	Number of squares occupied by land	=
Number of squares occupied by sea	=	Number of squares occupied by sea	=
Total number of squares	=	Total number of squares	=
Percentage of land	=	Percentage of land	=
Percentage of sea	=	Percentage of sea	=

Calculate which country has the greatest AFZ and territorial water.

---

### Questions

Google your answers to the following questions.

- Q1. Explain should fish stocks should be managed in an AFZ.

---

---

- Q2. Decide which fisheries of the Australian AFZ are over-exploited.

---

---

- Q3. Explain how aquaculture could sustain our fisheries.

---

---

---

- Q4. List three examples of difficulties encountered in preventing fish stocks in the AFZ from being over exploited.

---

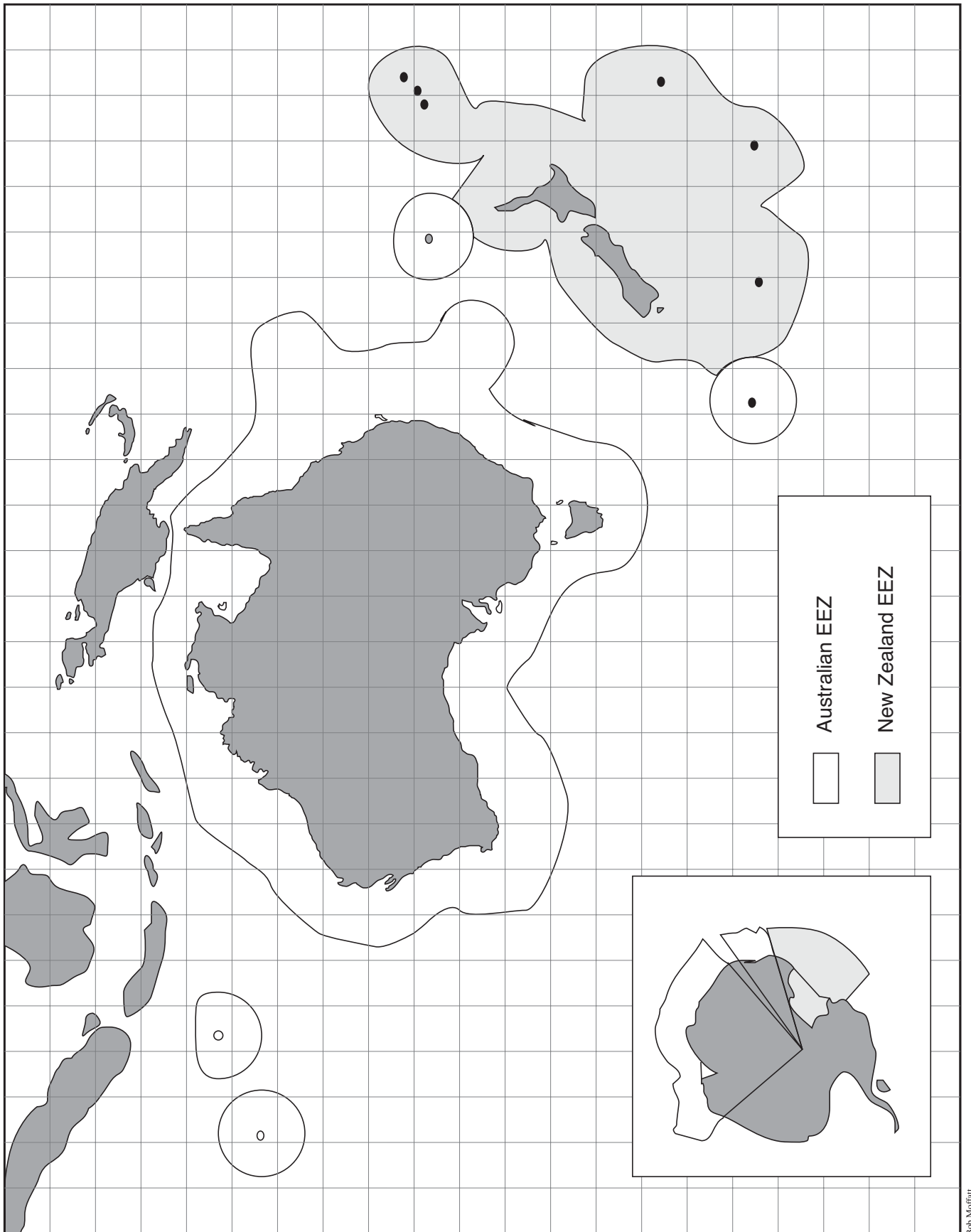
---

---

- Q5. Explain how water pollution, coastal development and poor catchment practices make it difficult to maintain biodiversity in the AFZ.

---

---



Bob Moffatt

Figure 157.1 Grid for AFZ exercise

## 4.18 Trade waste

In many Australian States proposed or existing legislation prohibits the discharge of any chemical into the marine environment. This means the only place chemicals can be discharged is into the sewage system.

This exercise involves analysing local trade waste by laws and how they affect the marine environment.

### Class talk

Invite a trade waste inspector from your local authority to visit your class to discuss rules and regulations that pertain to the disposal of chemicals.

- Prior to the talk, write a letter sending a copy of this exercise and the table opposite.
- Indicate that names of companies are not required, but the class would like some general information about the types of business or industry that discharge into the sewer and some of the chemicals that are discharged.
- Complete table 1 opposite during the talk and then arrange for a visit to the sewage or waste water plant to see how this waste is treated.

### Excursion

Arrange an excursion to the local wastewater treatment plant, complete table 2 opposite and research the following questions.

Q1. Estimate how many mega litres does the plant treat each day.

---

Q2. Estimate how far from a marine protected area or conservation area of significance does the plant discharge its waste water.

---

---

---

Q3. Recall if the plant is primary, secondary or tertiary in its treatment of sewage. Explain your answer.

---

---

Q4. Research if the plant removes heavy metals and if so how.

---

---

Q5. Research how water is conserved in the process.

---

---

---

**Table 1**

Type of industry/school or domestic property	Some of the chemicals it discharges
General comments on potential harm to marine resources if waste discharged directly into creeks and rivers	

**Table 2**

Stage of treatment	Type of chemical removal
General comments on the effectiveness of the sewage plant in conserving biodiversity of marine life	

Figure 159.1 Disposal of chemicals in your area.

## 4.19 Adopt an NGO

Note: This exercise needs to be started at the beginning of the year.

Non government organisations (NGO's) play a vital role in bringing attention to marine conservation issues.

Some of these organisations include:

- The Australian Marine Conservation Society (formally ALS)
- Marine Educators Association of Australasia
- Surfrider Foundation
- Australian Conservation Foundation
- Nature Conservation Agency
- Greenpeace

All rely on donations and membership fees to continue their work and volunteers who give their time to help protect our seas.

### Class assignment

Use the telephone book or other resources you can think of, to find out the name of a non government organisation that supports the conservation of the sea.

Find out how much it costs to join each association and when you have tallied up all the costs, organise a fundraiser to raise sufficient cash to join each for one year.

You could form groups and adopt an NGO.

Once you have joined, read through their literature to see how they go about protecting the marine environment.

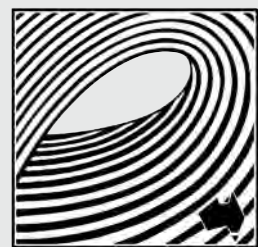
You could consider the following as a checklist.

- [ ] Does the group organise protest rallies?
- [ ] Is a newsletter produced?
- [ ] Does the group respond to calls for public submissions to management proposals?
- [ ] What issues does the group take a firm stand on?
- [ ] How much media coverage does the group generate if it feels that this is an avenue to achieve its aims?
- [ ] Does the group prepare reports, conduct field days, organise events such as Seaweek, Ocean Care Day?
- [ ] If these events are conducted, how can people become involved?

### An example of an NGO is Surfrider Foundation

Surfrider Foundation has adopted the following principles to guide and govern the activities of the organisation.

1. Surfrider recognises the biodiversity and ecological integrity of Australia's coast are necessary and irreplaceable. Surfrider is committed to preserving natural living and non-living diversity and ecological integrity of the coastal environment.
2. Surfrider promotes the right of low-impact, free and open access to Australia's oceans, waves and beaches for all people. Surfrider acts to preserve this right of access.
3. Surfrider is dedicated to enhancing coastal recreational opportunities in ways which will not adversely impact near-shore ecosystems.
4. Surfrider believes environmental education is essential to the future health and well-being of the planet. Surfrider seeks to develop and utilise educational materials that are informative, factual, proactive, synergistic and fun.
5. Surfrider strives to be accurate and nonpartisan in its communications with its members and the general public.
6. Surfrider is a grassroots organisation effective through the participation of its members. Surfrider activities emphasise the value of involved membership.
7. Surfrider encourages all commercial enterprises to adopt the Valdez Principles. Their determination to do so will favourably influence Surfrider's willingness to provide support. Surfrider will not permit sponsors to divert Surfrider from its mission or projects undertaken.
8. Surfrider does not discriminate on the basis of sex, religion, race or national origin for any reason. Surfrider promotes the healthy enjoyment of the coastal environment for all people.
9. Surfrider and its representatives, affiliations and branches agree to abide by these principles and rules governing non-profit organisations.



**Surfrider Foundation**  
A U S T R A L I A  
Conservation • Activism • Research • Education





- » Donate
- » Surf Reports
- » Surf Etiquette
- » Tribal Law
- » Surfers Code

- » About Surfrider
- » Membership
- » News Archive
- » Contact Us
- » Support Surfrider
- » Subscribers
- » Members
- » Galleries
- » Our Team
- » Press



Surfrider Foundation Australia  
Major Financial Sponsors



Surfrider Foundation is a not-for-profit organisation dedicated to the protection and enjoyment of the world's oceans, waves and beaches for all people.

**JOIN UP!**  
Become a member today!

■ **MAKE WAVES** ■ Kirra (QLD): Bring Back the Waves

If you were lucky enough to catch the Jack Johnson concert tour (brilliant, by the way), then you may have noticed a film projected on the screen at the back of the stage featuring the Bring Back Kirra campaign. Thanks Jack! If you would like to find out more or lend support to this campaign please contact our National Office.

**The end result?**  
With a little effort, careful planning and sound management we could have it all!



- The return of Kirra reef, an important ecological resource
- Well-managed surfing banks on the southern Gold Coast, which provide a variety of surfing amenity including the return of Kirra Point's safe navigable bar at Tweed Heads
- Protection of private and public property on the Gold Coast from storm surge and erosion
- A Shoreline Management Plan for the southern Gold Coast that is supported by the community, which includes a vision for the beaches and the surf zone as well as the foreshore

Surf to Save Kirra Contact Photo Gallery

Contest organiser John Bradford teamed up with the Kirra Surfriders Club and Surfrider Foundation Australia on Saturday the 16th of February 2018 to hold a surfing event in aid of the Bring Back Kirra campaign.

Special thanks to Peter Turner and Kirra Surf, Stomp surf wax and Surfrider Foundation for providing prizes. Lunch was provided by Kirra Pizza Hut.

Wayne "Kabbi" Bartholomew, Chayne Moran, Stuart Ball, John Bradford and Neil Lazarow spoke at the presentation on topics including the need for recognition of surfing amenity, the economic value of surfing, the scenic nature of Kirra and the generosity of who have missed it.

Hopefully the event won't be required annually. Maybe one day all the crew can get together and have a Surf to Enjoy Kirra back at the point.

[Read more about the campaign...](#)

■ **UPDATE** ■ Catherine Hill Bay (NSW): Concept Plan Rejected



This development proposal will have severe impacts on the village of Middle Camp. The proposal entails building houses to the north, south, east and west of the village and, as such, will be highly visually intrusive. 300 new houses on top of the existing 54 will smother the heritage village.

Find out more at the campaign web site ...

■ **ACTION** ■ Remote Marine Wilderness Debris Cleanup - SW Tasmania



In 1999 Surfrider Foundation began a campaign to address the massive problem of marine debris washing onto Tasmanian shorelines. Apart from causing unsightly pollution on our beaches, marine debris causes the cruel death of uncounted numbers of marine mammals, birds, and fish species.

Surfrider Foundation Australia has now conducted 6 clean ups on the beaches and rocky shorelines in the South West Wilderness World Heritage Area... Find out more...

■ **CAMPAIGN** ■ Tasmanian Pulp Mill

The Surfrider position is that, by allowing Gannet to construct their \$1.7 billion mill before the required scientific work is complete, a dangerous game is being played with Tasmania's beaches, surfers and coastal environment.

Surfrider Foundation Animation



Surf's up! Coastal Watch

Surfing and Climate Change

■ **Greening the Green Beaches from the UK**

"...couldn't see what an environmental gem it is. Trees of wonder!"

"I don't know how green proper is a proper better, we're green when we're green. We're green when we're green. We're green when we're green. We're green when we're green."

World geography with aviation's climate change footprint

- An idea for action on climate change. How lucky do you feel? From You Tube to the Global Greenhouse
- Surfrider policy on

Surfrider



**GREENPEACE AUSTRALIA PACIFIC**

Following the three-day protest by Greenpeace activists aboard a logging ship in Papua New Guinea's Aia River, a logging company in the region has finally promised to review the logging agreement for a site covering 1.7 million hectares. [Read more](#)

**Latest climate change blog**

- [UK jury rules climate damage justifies coal protest](#)

**Latest news**

**Protecting forests saves our climate**

Greenpeace has launched our Forests for Climate tour with a colourful welcome in Papua New Guinea. Our ship, Esperanza, will tour the region protecting forests and showing how deforestation contributes to climate change.

- [Read More](#)
- [View the slideshow](#)
- [Take action](#)

**Latest photo story**

**Saving the Paradise Forests**

September 2008: Greenpeace stopped a shipment bound for China, carrying piles of logged timber from the Paradise Forests. Our peaceful act was greeted joyously by local people who watched from boats, singing and dancing.

- [Read More](#)

Greenpeace



Bob Moffatt

## 4.20 MESA Seaweed and Ocean Care Day

Seaweed is organised each year by the Marine Education Association of Australasia or MESA. Ocean Care Day is organised by Surfrider Foundation, Ocean Rescue 2000 and the Australian Conservation foundation.

Here are some themes and activities that have worked in the past and which your class could do to draw attention to the need to create awareness of the marine environment.

### Themes

- Caring for our Coast, Celebrate the Sea, Fish for the Future, Respect the Beach
- Why not come up with your own theme?

### Activities

- Discovery tour to local island
- Face painting, reef mural, static displays
- Marine Olympic competition
- Water testing for pollution
- Beach clean-ups
- Public seminars
- Poster competitions in schools
- School video competition
- Production of 30 second TV commercial
- Beach concert
- Diving workshops
- Surfing competitions
- Planting trees
- Sand sculpturing competitions
- Aqua shell orchestral concerts
- Coastal walk-a-thon
- Adopt a beach activities
- Aboriginal dreamtime stories
- Writing articles for local newspapers
- Displays in libraries and shopping centres
- Environmental plays
- TV environmental segments

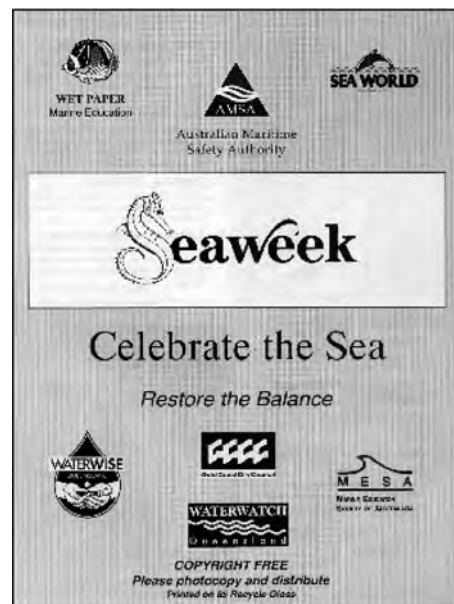


OCD - First Sunday in Summer



Bob Moffatt

Seaweed - First week in March



Bob Moffatt

Figure 162.1 Why not design a brochure for Ocean Care Day or Seaweed?



Bob Moffatt

Figure 162.2 Why not organise a beach clean up and group surf for a Sunday in Seaweed?

## 4.21 Become a reef guardians school

The Reef Guardian Schools Program is an education initiative of the Great Barrier Reef Marine Park Authority that aims to develop partnerships between schools, government, industry, environmental groups and local business in order to work together towards a more sustainable future for our natural resources and in particular the Great Barrier Reef.

It is an excellent conduit through which schools can promote sustainable environmental practices within their local community, whilst projecting a positive image of the school itself.

Reef Guardian Schools commit to participate in projects and activities that relate to four key criteria:

### **Curriculum**

Implementation of teaching and learning opportunities focused on the Reef, sustainability and/or other parts of our natural environment.

### **Resource management**

Refuse, reduce, reuse and recycle resources such as waste, water and energy.

This also includes working towards improving the biodiversity of the school grounds.

### **On-ground projects**

Students participate in experiential (hands-on) learning projects.

The size and scale of on-ground projects is dependent on the school's location, student numbers, ages of students and the partnerships established within in the local community.

### **Education of the community**

Encourage others to adopt best environmental practices through announcements on school assemblies, in school newsletters, media opportunities and Reef Guardian displays at school and community events.

The Reef Guardian Schools Program is a dynamic program that unites teachers and their students in a common goal of protecting the Great Barrier Reef.

Schools participating in the program consistently report that it provides cohesiveness amongst the school and its community and generates a can-do attitude amongst learners of all ages.

For more information about the Reef Guardian Schools Program please visit the Reef Guardian section of the Reef ED website -

[www.reefED.edu.au](http://www.reefED.edu.au)

Email: [education@gbrmpa.gov.au](mailto:education@gbrmpa.gov.au)



Australian Government

Great Barrier Reef  
Marine Park Authority

For more information about  
Reef Guardians  
visit  
[www.reefed.edu.au](http://www.reefed.edu.au)

## 4.22 Riparian habitat assessment

### Questions

Download Chapter 5 of the WaterWatch Queensland manual and answer the following questions.

Q1. Explain the significance of the sign in the photograph on the page opposite.

---

---

---

Q2. Mark in the following terms on the diagram at the bottom of the next page - *riparian zone, verge vegetation, floating vegetation, emergent vegetation and submerged vegetation*

Q3. Explain how sea grass beds could be affected by removal of the trees in Figure 165.2. Refer to the illustration in your answer.

---

---

---

Q4. Suggest possible side effects on coastal fauna if the trees were cut down to make a nice view for a coastal development.

---

---

---

Q5. Suggest one role riparian vegetation plays in the conservation of animal corridors.

---

---

---

### Field work

1. Complete the habitat assessment sheets from Chapter 5 of the WaterWatch Queensland manual.
2. Find a marine reserve and if necessary obtain a permit to complete a vegetation study of an area which runs into a local creek or river.
3. Find out the names of local vegetation species and complete a vegetation transect and riparian assessment using the reference materials supplied.
4. Complete an ecological succession study for your local area using the transect method.

#### Materials and equipment (per group)

##### Reference materials

- Download a copy of Chapter 5 WaterWatch Queensland Technical Manual

available from:

<http://www.qld.waterwatch.org.au>

See also waterwatch from other States eg Vic and Streamwatch in NSW





Bob Moffatt

Figure 165.1 The importance of our catchment



Bob Moffatt

Figure 165.2 Estuarine creek cross section.

## 4.23 Water velocity in a catchment

### Aim

To compare the infiltration rates of water on two different catchment surfaces and suggest possible pollution implications for creeks and rivers.

### Questions

- Q1. Plot a graph in the space provided in Figure 167.1 to compare the stream flow rates for the two coastal creeks identified in Figure 167.2.
- Q2. Mark on the graph the following observations:
- great and earlier peak discharge
  - more runoff volume
  - rapid recession
  - smaller and less rapid peak
  - greater recession
  - increased base flow due to irrigation
- Q3. Make up a table comparing the two creeks using the observations made in Question 2.
- Q4. Describe how increased flow rate affects a coastal creek.

---



---



---



---



---

- Q5. Oysters growing in a creek mouth have been tested and found to contain faecal coliform bacteria at levels 100 times permissible standards.

Suggest what signs should a local authority put up and explain why bacterial levels have increased.

---



---



---

- Q6. Phosphate levels can be reduced by adding soaking drains to a creek's verge vegetation system.

Suggest the purpose of these drains and why phosphate levels should be reduced in the creek.

---



---



---



---



---



---

#### Creek A Urban situation without riparian zone

Time in minutes	Stream flow rate metres/sec
2	0
4	0
6	0
8	0.5
10	1.0
12	2.7
14	6.9
16	19.2
18	14.3
20	12.1
22	8.1
24	6.1
26	4.5
28	2.3
30	2.1
32	2.3
34	3.4
36	2.1
38	1.4
40	1.4

#### Creek B Urban situation with riparian zone

Time in minutes	Stream flow rate metres/sec
2	0
4	0
6	0
8	0
10	0.2
12	0.4
14	1.1
16	3.5
18	3.1
20	2.1
22	1.1
24	0.5
26	0.5
28	0.4
30	0.2
32	0.2
34	0.0
36	0.0
38	0.0
40	0.0

Figure 166.1 Data from two creeks

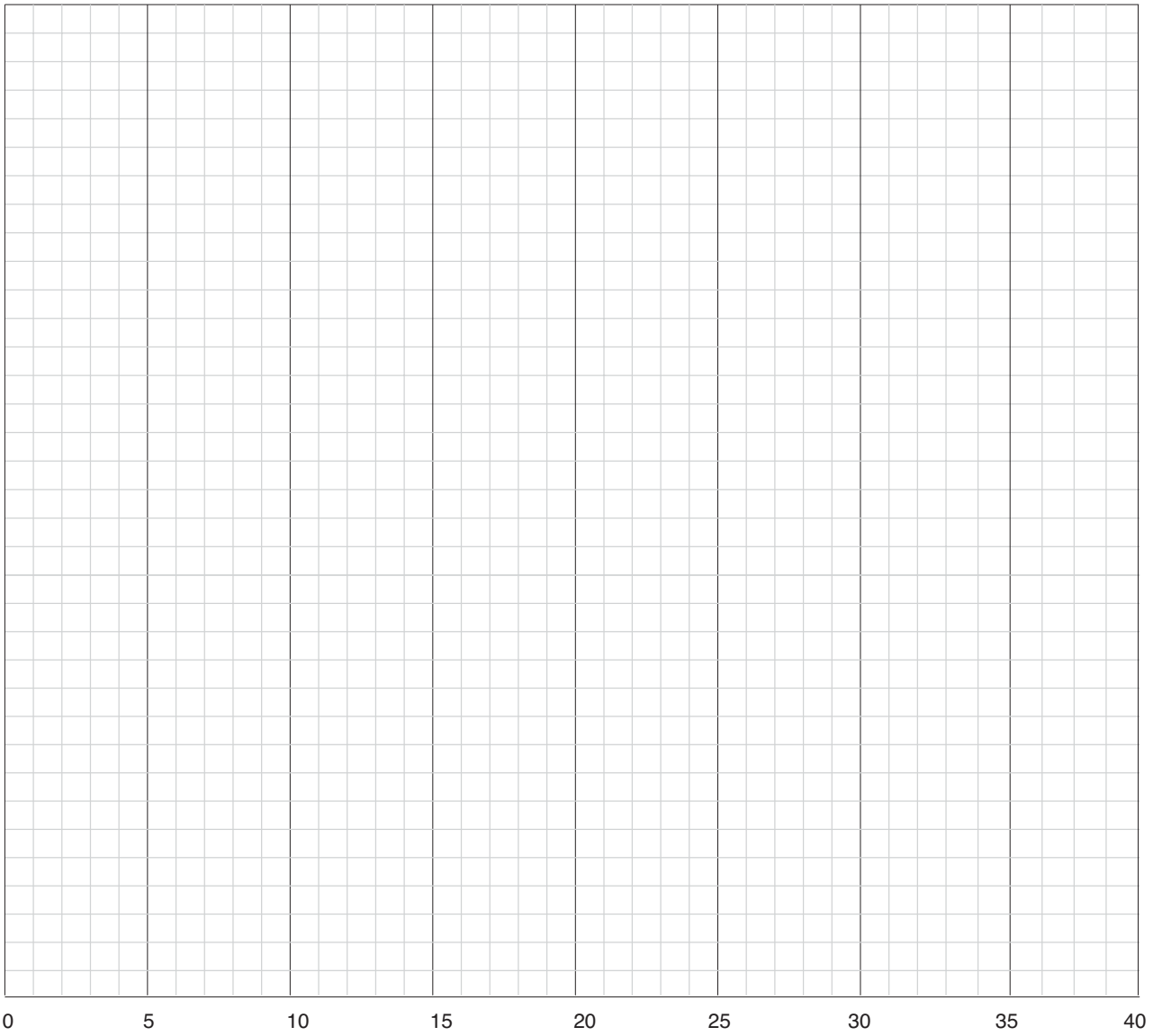


Figure 167.1 Graph from two creeks

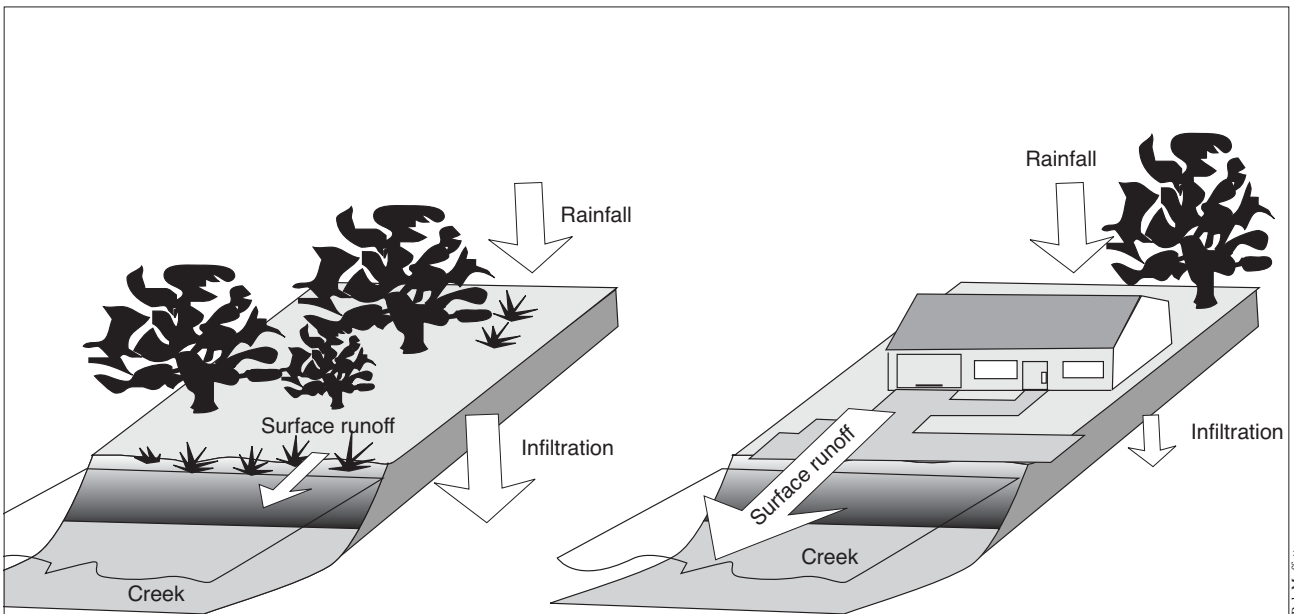


Figure 167.2 Comparison of two creek's riparian vegetation.

## 4.24 Sourcing litter pollution

### Aim

To analyse litter types on a beach

### Method

1. Select a sample site for the collection of litter from a stormwater drain or creek.
2. Using rubber gloves collect all the litter that has accumulated.
3. Sort this out on a clear piece of ground and do a count of the litter that has been collected.
4. Group the data so that a percentage estimate can be reached by either of the following methods:

- The number of items method

Suppose you have sorted the litter out into six large groups.

If there are 100 cigarette butts, 30 plastic bags, 35 drinking straws, 6 coke cans and 2 PET bottles – add up the data and present its shown in Table 1.

Now draw graphs to show your data in the space below.

- The rough volume method for litter analysis

The volume method involves stuffing the sorted litter into bags and arranging the bags as close to each other as possible.

The entire area of bags = 100%

By inspection and with group consensus, assign a percentage value to each of the bags as shown in Table 2.

**Table 1**

#### Litter analysis by number of items collected

Type of litter	No	Percentage
Cigarette butts	100	57.80%
Plastic bags	30	17.34%
Drinking straws	35	20.23%
Coke cans	6	3.47%
PET bottles	2	1.16%

Total	173	100
-------	-----	-----

**Table 2**

#### Litter analysis by bag volume

Type of litter	No	Volume Percentage
Cigarette butts	100	5%
Plastic bags	30	50%
Drinking straws	35	20%
Coke cans	6	15%
PET bottles	2	10%

Total	173	100
-------	-----	-----

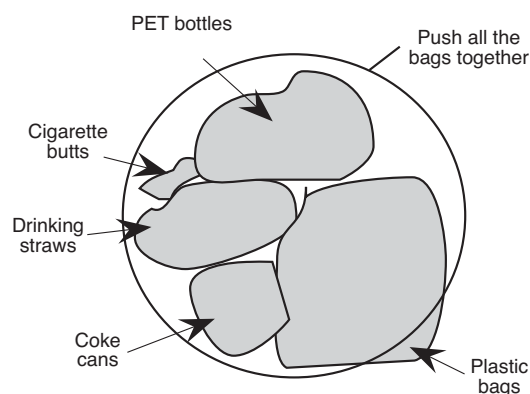


Figure 168.1 Estimate method for litter analysis

Bob Moffatt







Geoff Jensen

Figure 169.1 Students from Innisfail SHS sourcing litter



Bob Moffatt

Figure 169.2 Beach litter

## 4.25 Conflicts

Based on original exercises by Bob Moffatt and Tim Ryan

### Essays

Write an essay on one of the following topics depicted on these two pages.

#### *Either*

The *Australis humanii* as shown in Figure 171.1, is a quiet and sociable bird. It loves to collect many different objects. Here it can be seen on its nest.

1. Write a 300 word essay on the image this cartoon portrays.
2. Suggest some other characteristics of *Australis humanii*.
3. Comment on the future of *Australis humanii*.
4. Make a list of suggestions that might improve the future of this species.

or

Study carefully all the people and images portrayed in the figure on the next page.

Now write a 300 word essay of what you perceive to be the conflict arising from the relationship between community desires to preserve and use marine ecosystems.

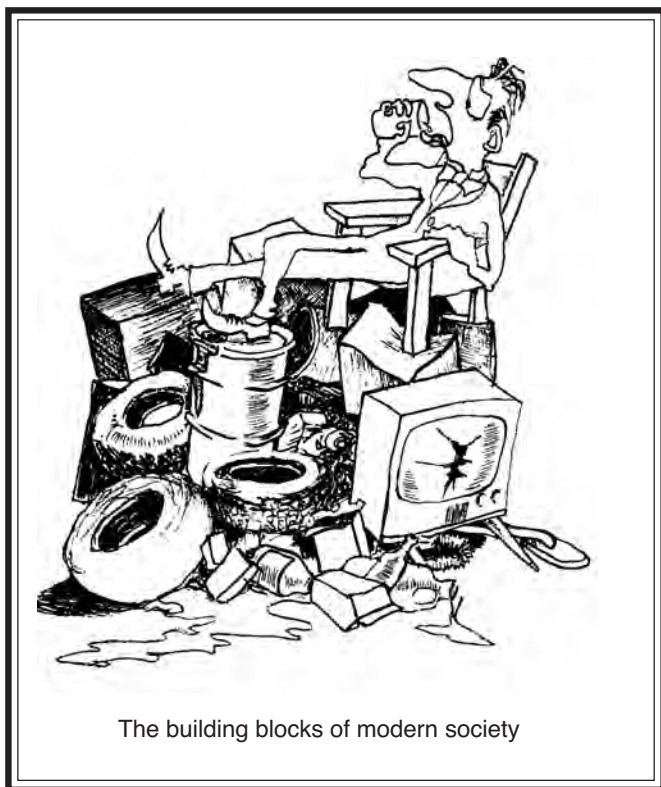


Figure 170.1 *Australis humanii*



Figure 171.1 Stimulus photograph

## 4.26 Dilemma exercise

### Questions

The following is a list of values about the coast.

1. Complete the sentences:

a. *Going to the beach is ...*

---

b. *The coast provides so many resources that there ...*

---

c. *Water is ... property and ...*

---

d. *The government and the local authority have ...*

---

e. *We should all ...*

---

f. *Freedom of action is ...*

---

g. *If you have to pay to go anywhere like the beach, then that is ...*

---

h. *I know what to do to ...*

---

i. *Beauty is in the ...*

---

Q2. Look at Figure 172.1 Suppose someone locates what appears to be an Aboriginal midden (an old feasting place) on one of the dunes close to the beach. Lots of shell remnants indicate the site. A group of surfers report these details to the local Shire Council who then has to decide what to do.

If the midden is fenced off from public access, and a notice put up saying “Keep Off” the site is quite likely to be vandalised. If nothing is done to identify the site, other people may destroy it by running over it, or digging it up.

State what you think should happen and justify your answer.

---

---

---

---

---

---

---

---

---

---

---

---



Figure 172.1 Somewhere on the coast of Australia



## 4.27 Writing a newspaper article

Based on an original exercise by Tim Ryan, Maryborough State High School.

### Method

1. Read the information in the boxed section in Figure 174.1.
2. Now use this structure to write a newspaper article or letter to your local member of parliament on a local management or conservation issue.  
The article or letter needs to discuss possible conflicts that arise from the relationships between community desires to preserve and use marine systems.
3. If you are hand-writing the article use the space on page 289 and make a sketch of a photograph that may accompany the article.
4. You may need to research the event fully before writing the article.

### Notes

---

---

---

---

---

---

---

---

---

---

---

---

---

---

---

---

---

---

---

---

---

---

---

---

### Newspaper articles

The purpose of a newspaper article is to inform. It is not a simple list of facts or a record of the event.

Structure of a newspaper article

- a. **Headline**
  - attention grabbing (eye catching)
  - abbreviated
- b. **Lead-paragraph**
  - readers like essential information first, to gauge whether they want to read further.
  - brief information such as who, what, when and where
  - introduction
- c. **Body**
  - more details of the event
  - can mention similar events
  - may use quotes to add interest and human factor
- d. **Sources**
  - comments by people involved
  - expert comment
- e. **Format**
  - photographs, maps, sketches may be incorporated to support or add meaning to the story
  - usually 25 word lead paragraph and 30 word paragraphs. When in columns information becomes dense if paragraph is too long

### Letter to local member of parliament

*To whom it may concern*

Have you been to the beach lately? As someone who derives great pleasure, not to mention indirect income, from the coast, I write to ask that you give its future and mine, your earliest attention and highest priority.

Seriously, this national treasure could become a national disaster if current management practices continue. I am fed up with the quality of my coastal environment deteriorating and call on your government to act upon the major recommendations of the Resource Assessment Commission's Coastal Zone Inquiry.

That includes a get tough approach to polluters, the phasing out of ocean outfalls polluting our surfing beaches and the indiscriminate development of the coastline which will affect the quality of life for generations to come.

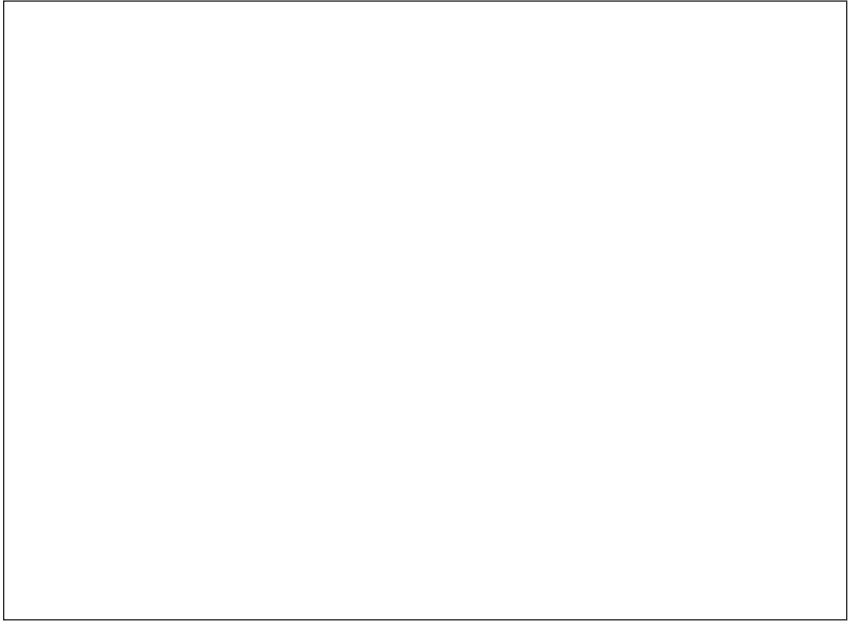
The Mariner City Conservation Foundation represents my interests and also those of most of the fourteen million other Australians who live on and love the beach.

I would like you to work more closely with the Mariner City Conservation Foundation on policy, legislation and management of the coast. Your government should also make a substantial grant to the Foundation to allow it to operate fully.

I look forward to your response to these requests and am very interested to learn of your plans to seriously address this critical issue.

Yours faithfully

Figure 174.1



A series of horizontal lines for writing, organized into three columns. The first column on the left contains 20 lines. The second column in the middle contains 20 lines. The third column on the right contains 20 lines. The lines are evenly spaced and extend across the width of each column.

## 4.28 Future problem solving

Based on an original exercise by Gwen Connolly.

### 5W+H

Who, What, When, Where, Why + How

### Method

1. In order to extract, enhance and organise information, we need a strategy which connects analysing and synthesising with the grammatical functions.  
A framework such as 5W+H will allow the access we need to any piece of writing. It will also stimulate further questioning and a flow-on of ideas.
2. Select a case study from the information on the next page.  
Then divide your class into 6 groups and call the groups Who, What, When, Where, Why and How. Label each group's piece of butcher's paper in the same manner.
3. Now read the case study you selected. In reading the case study, you must be able to extract the facts and then organise them so as to truly evaluate the study's worth.  
This activity will show you how this can be done.
4. Select a piece of butcher's paper for your group.  
It will be labelled either; Who?, What?, When?, Where? or How?

Brainstorm the problems in the case study and identify the problem by writing a sentence in the following format.  
Complete the statement — A person/s may/could be acting in a particular way at a particular time and place because \_\_\_\_\_

5. The underlying problem now needs to be identified and expressed as a How question.  
How can we (do something) so that (a result will be achieved) with (a person or group at a certain time and place?)  
Now brainstorm the solutions.  
(Say who should do it, what will be done, how, when and where.)  
In order to synthesise the best solution, all the solutions need to be evaluated using the same criteria. A criteria grid could be developed here to visually see which solution 'wins'. Now express this solution in the following manner: (who will do it, what will be done, how, when and where.)

---

---

---

---

---

---

---

---

---

---

---

---

---

---

---

---

---

---

---

---

---

---

---

---

---

---

---

---

---

---

---



## Case studies

Consider the following case studies, all of which have occurred in Australia in the past year or so. Each could form the basis of a separate problem solving exercise or class discussion. First, state the problem in each case.

Then decide: If you were the Local Government Council involved, how would you have proceeded? Again, if you were the State 'Co-ordination' Committee, how do you think the situation would have been resolved? Finally, suggest a solution or alternative which would reduce the impact on the coastal environment. (You may need to consult newspaper files for more details.)

1. The fishing people in Tasmania are demanding compensation for their fishing catch as it has been condemned for sale several times with high levels of mercury. The estuary of the River Derwent, downstream from Hobart, is suspected as the source of the mercury. Who should pay the compensation, if any?
2. Oyster sales from the oyster beds in the Hawkesbury River, north of Sydney, were stopped because of contamination of the oysters by sewage discharged from nearby settlements. Who should pay for the water to be cleaned up?
3. The fish on Brewer Reef off Townsville got so used to being hand fed by tourists visiting the Floating Hotel that they would still hang round waiting, over a year after the hotel has been removed. If fish become so conditioned to humans, should fish feeding by tourists in Queensland, and the rest of Australia be banned?
4. Two Taiwanese trawlers were apprehended off the Reef and brought into Cairns (Queensland) Harbour to face charges relating to their large, illegal catches of clam meat and trochus shell. Local fishing people and tourist operators are furious as they know more trawlers are getting away without being caught. They are demanding more patrol boats, more surveillance. Residents and conservationists are most concerned at a new proposal to increase the number of radar facilities which would assist in the surveillance of such boats, because these often have to be put on headlands in sensitive coastal National Parks. What should happen?
5. In November and December, a toxic algal bloom extended through the Murray-Darling system, threatening the fish and scallop industries of the lower Murray River in South Australia, and the stock and townships all the way down river who used the Darling and its tributaries as drinking

supplies. The algae was blamed on the increase in nutrient levels coming from sewage discharges from over 140 sewage works, and run off of fertilizers from farms along the river in Queensland and NSW.

Flood rains in mid-December flushed much of the system, but the farmers want to know: Who pays for the drinking water they had to buy when they and their stock could not use the river water? Will the bloom occur again?

6. A Greek oil tanker, "Kirki", spilled more than 23 million litres of crude oil into the ocean off Western Australia, threatening the spectacular reef system and the local island and mainland beaches, sea birds, fish and seals. A massive clean up operation involving chemicals, booms, and physically picking up the oil only succeeded because of unusually calm conditions. How can such environmental disasters be avoided?
7. The Commonwealth announced that to boost the economy and employment situation, it was 'fast-tracking' the proposed extensions to Sydney airport and that the third runway would be built into Botany Bay without waiting for the results of the environmental impact assessment. The runway will intrude into wetlands and the last remaining area of undisturbed land in Botany Bay.
8. Magnetic Island, off Townsville in Queensland, is the site at Nelly Bay of an abandoned multi-million 'reef city' of hotels, residences, and shops. The company involved (Interwest Holiday Group, financed by Tricontinental, and the State Bank of Victoria) was given approval to clear a headland, bury a famous beach and reef, and blast rock. Half way through the project, following long and costly legal proceedings by local conservationists, the company and its financiers collapsed. The promised bond of \$20 million to rehabilitate the land was not lodged with the Great Barrier Reef Marine Park Authority in whose area the development had been given permission to proceed. Who should now be responsible for returning the area to its once pristine state?

All of these cases require compromise, discussion, agreement between competing users and those concerned with management and preservation of the coast if any reasonable solution is to be found.

Obviously, one overall policy would greatly assist in the better preservation and use of our coastlines. Such a policy needs certain guidelines, or accepted principles, to make it appropriate.

Figure 177.1 Some case studies. You may want to consider a local development issue as well

## 4.29 Managers and user groups

Based on an original exercise by Tim Ryan, Maryborough State High School.

### Questions

- Q1. The figure on the next page shows a generalised diagram of how fish is distributed in the United Kingdom. Although the Australian fishing industry has developed in a very different way, the industry in the U.K. (shorter distances, no long distance offshore fleet, no state versus commonwealth legislation, and different types of fisheries) there are also many similarities.

Draw up a generalised diagram for the Australian fisheries based on the model opposite.

- Q2. The U.K. fisheries have a number of problems such as over fishing, competition from imports, problems of enforcing regulations and conflicts with other fishing nations.

Decide if Australia's fisheries have similar problems and support your answer with two examples.

---

---

---

---

---

- Q3. The U.K. fishers have seen continuing cost increase and this has seen the industry focus on ways to further reduce costs in areas of catching, processing, storage and distribution.

Suggest some ways of reducing costs.

---

---

---

---

- Q4. Outline the effect of some of the cost reduction methods on the community e.g. many may have technology replacing the labour force.

Outline what social problems may unemployment cause.

---

---

---

---

- Q5. Explain how better marketing of the produce increase rewards to the fishing industry.

---

---

---

---

---

---

### Extension questions

1. Research the library to provide information on the control of Australian fisheries.
2. Draw a flow diagram to show this control. Do you believe this control is necessary?  
Suggest improvements to existing legislation in Australia.

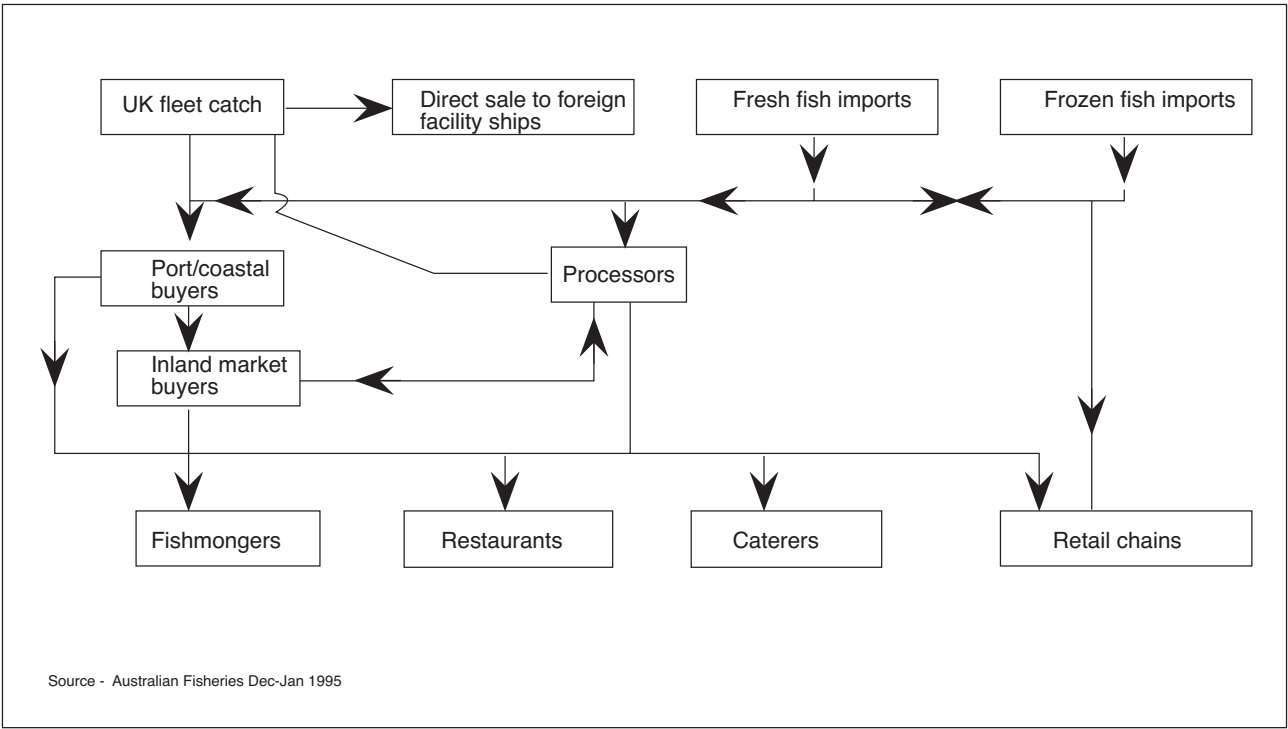


Figure 179.1 Generalised diagram of United Kingdom fish distribution



Figure 179.2 Generalised diagram of Australian fish distribution.

## 4.30 Management proposals

Based on an original exercise by Tim Ryan, Maryborough State High School.

### Questions

- Q1. Complete the speech bubble in the cartoon on the page opposite using the theme that there are management proposals in place but a fish kill has still occurred.
- Q2. Complete the table at the bottom of the page opposite.
- Q3. Complete any one of the following
  - Produce your own cartoon which may explain an aspect of management and conservation. The cartoon should be of a standard that could be used in the school newsletter or local paper.
  - Produce a comic strip suitable for a Grade 1-3 primary school student that gives them an insight into the problems facing the sea.  
*"How I love the velvet blue,  
the dawning of the sun.  
On glistening tropical waters  
it makes my heart go calm."*
  - Compose a song or poem to highlight your interest in the sea.
  - Design a word puzzle or crossword which contains many of the important terms used in the study of management and conservation.
  - Create a board game that could be played to demonstrate the problems faced in the management and conservation of the sea. It should be interesting to play and have an element of fun in it.
  - Design your own poster on the theme, 'Interrelationships between marine organisms and habitats'.
  - Write a short play on the theme, 'Conservation of the Sea'.

---

---

---

---

---

---

---

---

---

---

---

---

---

---

---

---

---

---

---

---

---

---

---

---

---

---

---

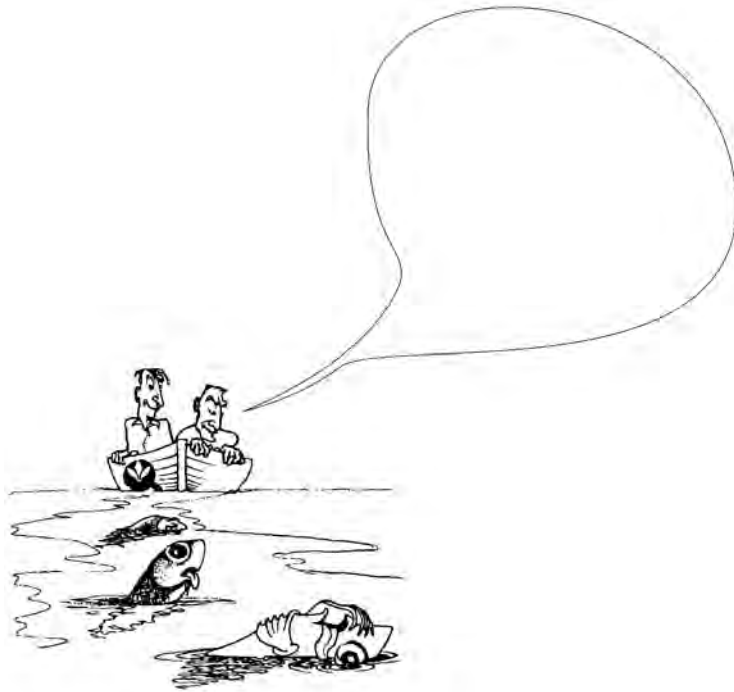


Figure 181.1 Fill in the speech bubble  
Tim Ryan

Management proposal	Possible reason behind proposal
Bag limit on fish	<hr/> <hr/> <hr/>
Limit development to 10 km inland of coastline	<hr/> <hr/> <hr/>
Convert all sewage to tertiary treatment and pump inland to be used in industry and new housing development	<hr/> <hr/> <hr/>
Establish marine protected areas along entire coast of Australia	<hr/> <hr/> <hr/>

Figure 181.2 Management proposals and the reasons behind them

## 4.31 Controversy at Hypothetical Bay?

The year is now 2015 and the redevelopment of Hypothetical Bay has gone ahead (See page 125 of your textbook - *Marine Science for Australian Students*. The following are newspaper articles extracted from the Mariner City News.

**5W+H**  
Who  
What  
When  
Where  
Why  
+ How

### METHOD

1. Read each article carefully.
2. For each article, write down the main environmental issue.
3. Write down the names of the people mentioned in the article and the organisations, government agencies or groups they represent.
4. Count up the number of points made in the article to see if the article is balanced. You might like to score each paragraph or just give an overall impression. The most important thing is to form an opinion and explain why you came to that conclusion.

#### Article 1

### ROBERTSON TO DISCUSS SEWERAGE AT HALL ROCKS

**Environment Minister, Mary Robertson, will announce at Hall Rocks today preliminary results of a statewide review of sewerage treatment plants.**

A spokesman revealed yesterday the survey began several months ago, and addressed Mrs. Robertson's concerns about a number of the state's sewerage treatment plants.

But he said that until the review was complete no single area or authority would be specifically identified.

"There may be a number of prosecutions initiated and we

don't wish to prejudice our legal position," he said.

The Minister's announcement coincides with her opening of a special 'effluent' seminar at the Hall Rocks Bicentennial Hall, and follows allegations from the Surfrider Foundation that only one in five Hypothetical Bay councils complied with government discharge licenses.

Surfrider Foundation director, Brad Smith, said Collins Creek, Hall Rocks and Watson Bay councils were among a number of Hypothetical Bay councils short listed by the group for assessment for possible breaches

of effluent discharge standards.

He said actions of these councils would be investigated by independent assessors, an inquiry prompted by reports to the foundation, independent and "green" groups throughout the state.

The foundation's reports claimed some councils had been operating without licenses at times, and had exceeded license standards regularly.

Today's effluent meeting begins at 9 am and the public is encouraged to attend.



---

---

---

---

---

---

---

---

---

---

---

---

---

---

---

---

## Article 2

# MOST FALL FOUL OF SEWAGE ACT

AS few as one in 10 sewage plants are believed to comply with licencing conditions, the Department of Environment and Heritage has found.

Local councils, however, claim they have a clean slate.

Harbour Town environmental officer Len Anderson said that under the Clean Waters Act the local councils had to submit effluent test results to the department.

"Mariner City and Harbour Town Shires have spent millions of dollars upgrading their sewage treatment systems and there is certainly no problem with them," Mr. Anderson said.

But an environmental leader warned that the pressure of population growth in the area could limit the council's abilities to continue to cope.

Surfrider Foundation national executive director Brad Smith yesterday called on Harbour Town Shire to hold a waste

management crisis summit.

Environmental Minister Mary Robertson, speaking at a Hall Rocks seminar, said that the ability of most of Hypothetical Bay's sewage treatment plants to comply with their licence conditions was 'poor'.

In January, she ordered a performance review of Hypothetical Bay's sewage treatment plants 'to ensure that every sewage plant in Hypothetical Bay complies with the discharge standards stated in their licences'.

So far the review has shown that nearly 10 per cent of the licensees had no monitoring program in place.

"Compliance with all the quality and quantity parameters which are supposed to be monitored is relatively rare and is probably achieved by less than 10 per cent of licensees," Ms. Robertson said.

The Minister said she had written to the Local Government Association of

Hypothetical Bay in April about the results.

## Concern

"I said the matter was a grave cause for concern and could not be allowed to continue", she said.

Hypothetical Bay Greens' convenor Drew Ham yesterday criticised individual councils for a 'lack of motivation' to ensure they complied with the Act and the State Government for 'a lack of enforcement'.

He said that the State Government had not monitored compliance through random checks and there was no motivation for councils to comply.

While Mrs. Robertson declined to name individual councils because of possible legal action, Mr. Ham said there were concerns on the Sunshine Coast and in Townsville and Cairns.

## Article 3

# CESSPOOL FEAR IN LYNCH RIVER

A Mariner City environmentalist claims Lynch River is becoming a cesspool, and could pose serious health risks for swimmers and aquatic sports enthusiasts.

And he has attacked the State Government for failing to monitor water quality in the area.

Brad Smith, president of the Hypothetical Bay Surfriders Foundation, says the danger of infection is far greater than shark attacks, but does not attract the same publicity.

"Research has shown the water's faecal coliform count is well above accepted world health standards," said Mr. Smith.

He said anyone who immersed their head in the polluted water was running a risk of contracting infections, including those affecting delicate areas like the eyes, ears, nose and throat.

"This embraces sports like swimming, water ski-ing, jet ski-ing and

windsurfing," said Mr. Smith.

Mr. Smith said it was six years since the State Government had done an official study on the purity of Lynch River.

Since then it had become the catchment area for stormwater runoffs from thousands of Mariner City waterfront homes, and the dumping ground for waste and sewage from even more boats, due to subsequent marina extensions.

"Lynch River is being turned into a cesspool while the Government stands idly by," he said.

The Surfriders Foundation has appealed to Broadwater MP Alan Grim to support water quality tests by Mariner University, and help persuade the Government to force boaties to have coloured dyes in their holding tanks to pinpoint any illegal pumping out of waste.

"At the moment it's open slather for polluters and we should be taking measures similar to the ones used so successfully in Florida

where such things are mandatory," said Mr. Smith.

Mr. Grim said there was no question it was time for action on the points Mr. Smith raised.

"Lynch River is too precious to pollute, and I am happy to support any study which yields information, but some solutions are available already," he said.

Mr. Grim said the State Government should legislate 'urgently' to include sewage pumpouts in all new boats over seven metres.

He said while there was merit in the proposal to dye the waste released from boat holding tanks, caution had to be exercised in view of United States reports which claimed the dyes polluted the water more than the original problem.

"More research can help pinpoint sources of pollution," said Mr. Grim.



## Article 4

# COUNCILS FLAUNTING CLEAN WATERS ACT

**A SURVEY of almost 60 Hypothetical Bay sewage treatment plants has found that less than one in 10 fully complied with the standards of the Clean Waters Act.**

Environment Minister Mary Robertson, who announced the survey results in Hall Rocks yesterday, said her department was already preparing to prosecute some operators while others had been ordered to upgrade their plants.

The release of the survey results follows allegations by the Surf rider Foundation that only one in five Hypothetical Bay councils complied with government discharge licences.

Collins Creek, Hall Rocks and Watson Bay councils have all been short-listed by the foundation for assessment of possible breaches of effluent discharge standards,

Ms. Robertson, who opened a seminar on Hall Rocks's

sewage strategy, said she had ordered a review of the performance of the State's sewage treatment plants in January after being concerned for some time on the issue.

Nearly 200 letters were posted out to operators, including councils, industries and resorts, requesting the results of their own monitoring programs within 14 days.

About 18 did not even respond, while nearly 10 percent said they did not have monitoring programs as required by their licences.

Ms. Robertson said overall compliance with all the quality and quantity parameters, which are supposed to be monitored, was "relatively rare and is probably achieved by less than 10 percent of licences".

The department has since ordered licence holders to detail their plans to upgrade their practices and procedures to comply with their conditions.

"Let me be clear about this - the aim of this review is to ensure that every sewage treatment plant in Hypothetical Bay complies with the discharge standards stated in their licences. It is not about closing down sewage treatment plants - that serves no benefit," said Ms. Robertson.

But she said that those operators who refused to comply with standards would be prosecuted.

All three coast councils have been hit by allegations concerning their sewerage systems in the past year.

Yesterday's seminar at Sunshine Beach was convened by People Opposing Outfalls, the Surf rider Foundation and the Sunshine Coast Environment Council and sponsored by Hall Rocks Shire Council.

Surf rider Foundation Hypothetical Bay executive director Brad Smith said both Collins Creek and Hall Rocks, as ecotourism areas, had to give

a clear message to coastal councils around Australia that dumping sewage out to sea was no longer acceptable.

"If it can happen here, it is open slather around the coastline," Mr. Smith said yesterday at a seminar in Hall Rocks on sewage strategies.

And Mr. Smith has warned that Watson Bay City Council would one day live to regret installing its ocean outfall at Kontos Creek.

"The threat won't be realised by the local people here until there is a sheer crush of population growth in the area," Mr. Smith said.

He said that the outfall would in years to come pose a significant health threat to people bathing near the area, especially as discharge volumes increased.

Mr. Smith said the region's huge tourism industry relied on clean beaches and clean water to swim in.

## Article 5

# FEAR TOXINS COULD ENTER LYNCH RIVER

**FURTHER** development of the flood plain at Warne Cove could lead to deadly toxins finding their way into Lynch River, it was claimed this week.

The Australian Conservation Foundation has accused Harbour Town Shire Council of failing to act on a toxic creek at Warne Cove, although the council has known about the problem for more than a month.

Attacking the council for its lack of action, the secretary of the foundation, Matt Keysmith, said the council had been aware of the creek's condition for several weeks yet had done nothing.

"Two creeks flowing from the Warne Cove flood plain contain extremely high levels

of acid sulphate, a substance that is toxic to all marine life," said Mr. Keysmith.

"Potential acid sulphate soils are scattered throughout the Warne Cove and Merrimac flood plains.

"Leachate from these soils has been entering the canal systems through the creeks and poisoning Lynch River.

"Council officers have been aware of this problem for more than a month and yet nothing has been done to alleviate the situation."

Mr. Keysmith and Harbour Town Shire mayoral candidate Jeanie Keen has drawn the attention of the foundation to the condition of the Warne Cove flood plain.

Mrs Keen was concerned about

the toxicity of the area and had called for an environmental impact study of Jensen River.

Mr. Keysmith said acid sulphate soils contained aluminium, which was highly toxic to marine creatures.

"The mangrove creeks' drainage into canals from the Warne Cove flood plain contained fish and crab nurseries," he said.

"Oxidisation of acid sulphate soils has poisoned all species that had been breeding in this creek.

"The toxic flow has been allowed to continue poisoning Jensen River and Lynch River for the past four weeks."

Mr. Keysmith said the blame for this situation rested with Harbour Town Shire Council, as it had been aware of the high

level of acid sulphate in the flood plain for a number of years.

"Council is pushing to develop the Warne Cove flood plain at great peril to the health of Lynch River," he said.

"Disturbing the floodplain will lead to further toxic leachate entering the creeks and then Lynch River.

"The council needs to wake up and realise that further development on these flood plains will lead to more acid sulphate leaching into our waterways.

"The Harbour Town Shire draft town plan fails to address the issues related to potential acid sulphate soils so they could well be sitting on a toxic time bomb" said Mr. Keysmith.



Article 6

# LOCALS SET FOR MAJOR FIGHT AT COLLINS CREEK



Bob McEnt

Collins Creek residents at last week's protest rally against creek pollution

Mariner City community groups are gearing up for one of the biggest environmental fights on the tourism strip - the clean-up of Collins Creek at Batestown.

Collins Creek residents, greenies and Aborigines have vowed to take their case to clean-up the polluted waterways to the highest level.

Green activists and Aboriginal groups plan to use the rehabilitation of the creek to spearhead their environmental policy on the Mariner City.

At the second meeting of the Mariner City Aboriginal and Islander Co-operative on Saturday, the group resolved to use the creek rehabilitation as a pilot project in developing guidelines for community involvement in environmental management on the Mariner City.

Chairman of the meeting Mr. David Dawson said Collins Creek would be a good start to determine whether an environment advisory committee to the councils would work.

"It will be a good way to show our credentials and earn some respect," said Mr. Dawson.

"I do believe we have to get a working relationship with the council.

"With all of the parties working together in one direction, so much can be achieved."

He said the problem of sewerage overflow and back-up of water at Collins Creek had affected a large number of homes in the area.

Outraged Collins Creek residents are prepared to take their case to Environment Minister Mary Robertson in a

bid to have the waterway cleaned up.

The city council will be asked to put up signs, saying Collins Creek is a health hazard to swimmers.

This follows a protest meeting of about 200 Collins Creek residents held last week.

Local alderman Peter Lawless said the problem was a difficult one and dredging was not the answer.

Ald Lawless met the Wildlife Preservation Society last week in a bid to re-introduce wildlife to the creek.

Collins Creek has become a natural habitat for many species of waterbirds. Its tidal reaches are also a breeding ground for crabs and other marine life.

City Council health department experts took readings at Collins Creek on January 27.

The faecal coliform count on the corner of Barrattum St and Terrigal Crescent was 800 per 100 mL. Other readings along the creek were between 190 and 560.

One of the convenors of the public meeting, Jan Luscombe, said the condition of Collins Creek had a direct bearing on the quality of Lynch River.

She said swimmers were now risking their health by paddling in the creek.

"Collins Creek has become one of the dirtiest and most polluted stretches of water in Australia," she said.

"I blame the council for not doing something about it."

Ald Lawless said he had never seen any evidence of industrial pollution at Collins Creek.

Ald Criton said Ald Lawless "should be ashamed of himself and go and have a look at the problem".

## Article 7

# LYNCH RIVER HIT BY FATAL FLUSH

ENVIRONMENTALISTS fear Lynch River will become a giant lavatory bowl unless the Gross Government introduces hefty fines for polluters.

Lynch River pollution problem has also prompted the Mariner City Council to call on the Hypothetical Bay Government to introduce standard regulations for sewage disposal from boats.

Surfrider Foundation national president Brad Smith intends to discuss the problem with Environment Minister Mr. Pat Combener during talks in Brisbane today.

Mr. Smith said lobbying by his group about pollution problems in Sydney Harbour has resulted in new legislation to be introduced in July this year where polluters will face fines of up to \$1500.

Mr. Smith yesterday accused the Hypothetical Bay

Government of ignoring environmental problems on the Mariner City.

He said the government had given priority to buying and protecting large tracts of grazing land in western Hypothetical Bay.

"The Mariner City is very much undervalued by the State Government. We want them to establish a coastal pollution monitoring body," said Mr. Smith.

He said environmentalists were not satisfied with the monitoring of pollution in Lynch River.

Council inspectors have confirmed that water quality tests have sometimes revealed high levels of faecal coliforms near marinas on Lynch River.

The council staff believe the most likely reason for the high recordings was the discharge from lavatories on boats.

"Lynch River is being used as a giant toilet bowl. With the runoff of metals and pesticides, you have potentially a very lethal chemical cocktail there," said Mr. Smith.

"In the next 10 years we could very well see the demise of Lynch River as a recreational area."

Mariner City Council Planning and Development Committee chairman Alderman Peter Lawless said yesterday council staff had produced a policy document on the control of waste-disposal facilities at marinas.

Ald Lawless said the council would prefer the Hypothetical Bay Government to introduce a uniform policy rather than forcing the council to act independently.

"The future of Lynch River is at stake by developments and the dumping of sewage by boats,"

said Ald Lawless.

"The solution appears to be easy: boats should be required to have sewage holding tanks and sewage pump-out facilities should be built on all marinas."

Ald Lawless said the Transport Department should ensure that all new vessels in Hypothetical Bay contained suitable holding tanks and existing craft should be required to have similar equipment by the year 2000.

A Transport Department spokesman said the department was reviewing marine legislation regarding holding tanks and sewage facilities.

The spokesman said laws were introduced in September, 1991, which required new commercial vessels that were equipped with flush toilets to have holding tanks.

He said if future legislation was retrospective it could cause financial problems for boat owners.

## Article 8

# GREEN SEEKING END TO OUTFALLS

AUSTRALIAN Democrats leader Cheryl Green has called for the phasing out of sewage ocean outfalls by the year 2005.

Speaking at the Mariner City Marine Symposium yesterday, Senator Green backed a push by environmental groups for a moratorium on ocean outfalls.

"We have to turn it around now," she said.

Senator Green also criticised last week's Federal Government Budget which 'contained little for the environment in general and particularly for coastal management'.

Senator Green said she would lobby new federal Environment

Minister John Forktongue in a bid to have ocean outfalls phased out.

She said there was 'total conflict' in the Hypothetical Bay Government's newly-declared Mortonian Bay Marine Park being used by local councils for ocean outfall.

Mariner City mayor Gary Bailey yesterday said the city council's policy was to reuse as much of its effluent as possible on parks and gardens.

"We are up to 60 percent now," councillor Bailey said.

"The practicality of it is if you don't have ocean outfalls, what

do you do with it?"

When it rained, no one wanted treated effluent for watering and, while the reuse of effluent for domestic purposes was on the councils 'long-term' agenda, it would require public acceptance.

But Senator Green said there were alternatives being developed by private enterprise which could be considered.

Senator Green met Surfrider Foundation national executive director Brad Smith yesterday to discuss the issue.

Mr. Smith last week called for the Newtown Government to

stop its eight proposed ocean outfalls.

Mr. Smith said the moratorium bid was gaining support among politicians and lobby groups.

Senator Green said she hoped Mr. Forktongue would consider a set of national standards for effluent and stormwater management, which would include a moratorium on ocean outfalls.

Senator Green also wants a higher priority for coastal management.

"I plan to do everything in my power to persuade Mr. Forktongue," she said.

Article 9

# INSECTICIDE FIND SPARKS COMMUNITY OUTRAGE



Tim Ryan

Recent fish kill in Lynch River last Tuesday

A new insecticide, hypotoxinade, has been blamed for last Tuesday's fish kill in Lynch River according to Mariner City health inspector Ms. Wendy Watson.

"The insecticide came from an empty drum which was washed out into a stormwater drain and investigations will most likely lead to prosecution," Ms. Watson said.

Mayor of Mariner City Mrs. Sun Lu said that if any of the resorts were using it to kill mosquitos then they faced heavy fines and loss of licence to operate ecotourism ventures.

"In 1998 we had similar problems and it was agreed

that all facilities had to have on site treatment of all chemicals. Boats had to be washed down in places where all runoff could be trapped and treated on site and then discharged into the sewerage system," Mrs Lu said.

"People who continue to break this law would be heavily penalised."

Local Surfrider Foundation president Mr. Matt Keystone said it was an outrage that given the education programs in the community anyone should be so stupid as to tip anything down a stormwater drain.

"We already have problems with over crowding of our surfing beaches and the

continual threat of a major airport disaster. "

"The fifth runway planned will pass directly over the Slaughter National park and be an environmental disaster," he said.

According to local councillor and developer Mr. Max Milliamson, the fifth runway was necessary to keep up with the demand from Asian countries whose beaches had become so polluted they could go nowhere else for a holiday.

"Mr. Keystone is just trying to slow progress and with the recent downturn in the economy development is essential," he said.

## 4.32 Best environmental practices

Acknowledgement is made of the Great Barrier Reef Marine Park Authority for allowing reproduction of the draft statements of best environmental practice to be published here.

### Group discussion

Read the articles for discussion on pages 189 - 191 and discuss the following statements in your group.

Use the butcher's paper and pen provided to write all the reasons your group can think of as to why each rule was introduced.

Use the blue tack to pin these to the wall when finished and make a short presentation to the class.

1. If a vessel does not have a holding tank, visitors should use toilets before and after they reach the reef.
2. Where installed, use approved public moorings in preference to anchoring.
3. Fish should not be fed directly by hand, but fed by broadcasting food into the water.
4. Remove any seeds or introduced plants from your clothing or shoes before landing on an island.
5. Do not disturb seabirds or turtles. Avoid making loud noises, using strong lights or making sudden movements near to where turtles or seabirds are nesting.
6. Keep dogs away from turtles. Note: dogs are not permitted in National Parks or on most adjoining beach areas.
7. While on the island don't feed seabirds food scraps as they must learn to find their own food.
8. When diving do not chase or attempt to ride or grab free swimming animals. Avoid blocking their path.
9. When snorkelling do not rest or stand on coral. If you must stand up make sure it's on sand.
10. Make a common walking track to the beach when camping on an island.

### Alternate discussion

Read all the articles and rate those in order from most important to least important.

## MATERIALS AND EQUIPMENT (PER GROUP)

- best environmental practice fact sheets from next three pages
- butcher's paper
- blue tack
- marking pen

# WHILE ON THE WATER

## Waste disposal

Increasing nutrients in reef waters and marine pollution pose major threats to offshore islands and reefs. Many Governments have recently introduced legislation requiring all new vessels over a set length to fit toilets and holding tanks from January 1998. Existing vessels over 10 metres must be fitted with toilets and holding tanks by January 2000, unless they cannot be modified to hold a toilet and holding tank and obtain an exemption. Many governments are currently developing regulations concerning the discharge of wastes. Some Commonwealth authorities are considering the introduction of complementary legislation for sewage discharge.

The following legal requirements apply to the disposal of wastes in some Marine Parks:

- The discharge of garbage (including plastics) and oil products within a Marine Park is totally prohibited, with the exception of human wastes when discharged from a vessel and fresh fish parts from fish caught in the Marine Park.
- If a vessel contains a holding tank, sewage must be discharged more than 500 metres from the edge of the nearest reef.

Best environmental practices for waste disposal in a Marine Park could be:

- If a vessel contains a holding tank, use pump ashore facilities for sewage disposal wherever possible. Where these facilities are not available, discharge sewage in open water (e.g. shipping channel).
- If a vessel does not have a holding tank, visitors should use toilets before and after they reach the reef.
- Use biodegradable toilet paper and cleaning products.
- Petroleum products in the bilge should be broken down with biodegradable degreasers and pumped into onboard storage containers and disposed of at recycling depots onshore.
- Encourage visitors not to urinate in the water at the reef.

## Anchoring

Anchors and chains wreck fragile coral environments. Remember coral is a living organism. Each anchor makes a difference. Anchor with care.

In a Marine Park you are required to comply with anchoring areas.

Best Environmental Practices for anchoring in a Marine Park could be:

- Where installed, use approved public moorings in preference to anchoring.
- Carry the right gear - enough chain or line to anchor on 30 metres of water.
- Check out the area before anchoring.
- Anchor in sand or mud away from live corals and be sure your chain is clear of coral.
- Motor towards the anchor when hauling the anchor in.

## Fish feeding

Fish feeding is one of the most popular activities carried out from tourism vessels and is often the highlight of many visitor's trip to a Marine Park.

Commercial tour operators require special permission from the some Commonwealth authorities and environment departments to carry out fish feeding and are provided with guidelines outlining how to conduct activities. Fish feeding may result in undesirably aggressive behaviour in some fish and can be dangerous to the person feeding the fish or others close by in the water.

Most food fit for humans is not suitable for fish and may damage their health. Please help to ensure the effects of fish feeding are minimised by following the best environmental practices outlined below:

- If you are feeding fish as part of a tourism operation, fish feeding should only be conducted by staff.
- Fish should not be fed directly by hand, but fed by broadcasting food into the water.
- People should not be in the water at the time of fish feeding.
- Feed fish only raw marine products or fish pellets.
- Feed fish no more than 1 kilogram of food per day per site on the reef.

## Fishing

The most popular recreational past time on reefs is fishing. Fishery stocks need everyone's help to remain at a sustainable level.

In many Marine Parks it is a legal requirement to abide by Zoning Provisions (no fishing in green zones and some restrictions in yellow zones), bag limits, size limits and seasonal closures.

Best environmental practices for fishing could be:

- Take only what you need.
- One fish one hook.
- Resist fishing spawning aggregations.
- Report any tagged fish caught to the Department of Primary Industries, (toll free number 008-077001).

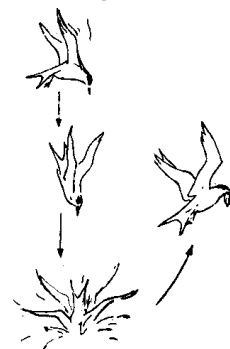


Figure 141.1 An article for discussion — best environmental practice while on the water

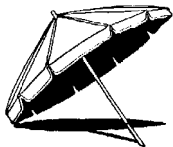
# WHILE ASHORE

## Visiting Islands

Islands within Marine Parks are a popular destination for tourists and locals alike.

Best environmental practices for visiting islands in a Marine Park could be:

- Check with your local Department of Environment office before visiting islands for any special requirements, and obtain appropriate permits before camping. Camp only in designated camp sites.
- Check on Marine Park Zoning requirements before fishing and collecting around islands.
- Take any litter or rubbish back to the mainland for disposal.
- Do not use detergents, toothpaste or soap in creeks or streams. Wash at least 50 metres away from water courses.
- When cleaning dishes use sand and a scourer to remove waste.
- Use gas or liquid spirit stoves for cooking. Open campfires are not encouraged, and are not permitted in some locations.
- Always use toilets where provided.
- Where toilets are not provided, select a spot at least 100 metres away from campsites and water courses. Dig a hole at least 15 centimetres deep and bury all faecal material.
- Remove any seeds or introduced plants from your clothing or shoes before landing on an island.
- Do not disturb vegetation or break branches from trees or shrubs.
- Do not disturb seabirds or turtles. Avoid making loud noises, using strong lights or making sudden movements near to where turtles or seabirds are nesting.
- Do not take animals or plants on to islands nor feed the native animals.
- Do not write or place graffiti anywhere.
- Keep to common walking tracks or designate a common track to follow.
- Do not use generators or compressors unless you have special permission.
- Do not play amplified music on island National Parks.



## Reef walking

Reef walking is a popular activity for exploring the intertidal area or reef flat. Reef walking has the potential to be particularly destructive to the marine environment. Please help to ensure human impacts are minimised.

Best Environmental Practices for reef walking could be:

- Watch where you walk so as not to step on any coral or living matter.
- If there is a marked trail, follow the markers and avoid straying or taking short-cuts.
- If there is no marked trail take time to find any regularly used trails or, follow sand channels.
- Use a pole or stick for balance and not to poke or prod animals.

- Return any boulders you overturn to their original position.
- If you pick anything up, living or dead, always return it to the exact position in which you found it.
- Do not pick up or remove species which are attached to the reef flat.
- Be aware of Marine Park collecting restrictions.

Additional practices for guided reef walks:

- Keep group size to a maximum of 15 people wherever possible.
- Keep walkers in a group on the reef flat, and where possible break the main group into smaller groups.
- When following a marked trail, maintain single file formation between points of interest.

## Turtle watching

Some reef islands are a critical breeding ground for sea turtles or penguins which come ashore at night to lay eggs and are easily disturbed by light, noise and movement. Whilst it is possible to watch the females laying eggs, and hatchlings emerge from the sand, please ensure your presence does not adversely affect this wonderful breeding process.

Best environmental practices for turtle watching could be:

- Keep the use of lights to a minimum while you are walking along the beach.
- Do not approach closely or shine lights on the turtle as she leaves the water or moves up the beach.
- Wait until the turtle is laying her eggs before shining lights on her.
- Avoid excess noise and sudden movements.
- Keep dogs away from turtles. Note: dogs are not permitted in National Parks or on most adjoining beach areas.
- Learn about the habits and needs of turtles.

## Observing seabirds

Many reefs are the home to thousands of seabirds which have flown a very long way to rest before continuing on. Many of the islands play a critical role for seabirds as breeding and nesting sites. Be aware of protected areas and seasonal closures in Zoning Provisions, and help to minimise sea bird disturbance. Some key island nesting areas are totally closed to entry.

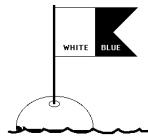
Best Environmental Practices for observing seabirds could be:

- Be quiet and avoid rapid or sudden movement.
- Avoid walking near or over areas where ground nesting birds are present.
- Approach seabirds crouching down and where possible make use of existing cover to observe birds.
- Don't approach seabirds to the point where they become nervous and above all don't chase birds away.
- Don't walk into roosting or nesting colonies, or cause birds to move from nests or young.
- Minimise and where possible avoid using lights near or in the bird colonies.
- Take particular care on seabird islands at the following sensitive times:
  - late afternoon, early evening, during the hottest part of the day, in wet / or cold weather, moonlit nights, when eggs, naked or downy chicks are in their nests.
- Learn about their habits and needs and don't feed them food scraps as they must learn to find their own food.



Figure 190.1 An article for discussion — best environmental practice while ashore on an offshore island or reef

# WHILE IN THE WATER



## Diving

Scuba diving is one of the most popular activities in a Marine Park. All divers should be aware that it is an offence in the Marine Park to damage or remove coral. Ensure that your diving has minimal impact.

Best Environmental Practices for diving in a Marine Park could be:

- Practice buoyancy control and ensure you are weighted correctly.
- Do not rest or stand on coral. If you must stand up make sure it's on sand.
- Avoid touching anything with your fins and be aware of disturbing sediment or coral.
- Secure dragging equipment such as gauges.
- Observe animals rather than handle them directly. Handling some animals may be dangerous.
- Do not chase or attempt to ride or grab free swimming animals. Avoid blocking their path.
- Do not poke or prod any plants or animals.
- If you pick up anything under water, living or dead, always return it to exactly the same position.
- Do not lean on coral to support yourself while taking underwater photographs.

## Snorkelling

Snorkelling is one of the best ways to explore a Marine Park.

Best Environmental Practices for snorkelling in a Marine Park could be:

- Practice snorkelling techniques away from living coral.
- Control your fin kicks, especially in shallow water.
- Avoid touching anything with your fins, and be aware of disturbing coral and sediment.
- Do not rest or stand on coral. If you must stand up make sure it's on sand.
- Observe animals rather than handle them directly. Handling some animals may be dangerous.
- Do not chase or attempt to ride or grab free swimming animals. Avoid blocking their path.
- Do not poke or prod any plants or animals.
- If you pick up anything under water, living or dead, always return it to exactly the same position.



## BEST ENVIRONMENTAL PRACTICES IN GENERAL

- Respect any areas of cultural or historical significance.
- Respect other people using a Marine Park.
- Be aware of the effect of your activity on other people and avoid conflicting activities in the same area.

- Take the time to learn about a Marine Park and how to minimise the impact of your activity on a reef environment.

## Reporting procedures

You can help managing agencies to manage a marine park and islands more effectively by assisting in the reporting of any of the following activities or incidents:

- Any suspected breach in law (including illegal fishing and collecting) to your nearest Marine Parks office.
- Oil spills or any form of marine pollution.
- Marine mammal sightings.
- Crown of thorns starfish, suspected ballast water invaders (see exercise 99 or *Drupella* sp if you live in WA).
- Natural history observations including fish spawning, coral bleaching and algal blooms.

## Research activities

Understanding how the natural ecosystem works and the effect of human interactions with the environment is fundamental to the successful management of a Marine Park.

Research activities have the potential to significantly impact on the marine environment.

In some states it is a legal requirement to obtain the necessary permission from the Management Authority to conduct a research program.

Best Environmental Practices for research activities in a Marine Park could be:

- Ensure your research program is having minimal impact on the physical reef environment and the visual aesthetics of frequently visited sites.
- Ensure your activities are not interfering with those of other reef users.
- Explain the purpose of the research program to interested reef users and where appropriate provide the opportunity for community involvement.
- Provide updates on the progress of the study and feedback research results to those who have provided assistance in setting up and conducting the research program.
- Remove any hardware from the study site following the completion of the research program.



Figure 191.1 An article for discussion — general best environmental practices including while in the water

## 4.33 Problem solving

Based on an original exercise by Gwen Connolly.

### Method

- In order to extract, enhance and organise information, we need a strategy which connects analysing and synthesising with the grammatical functions.  
A framework such as 5W+H will allow the access we need to any piece of writing. It will also stimulate further questioning and a flow-on of ideas.
- Select a relevant article to your area or use the one provided in the figure on the page opposite  
Then divide your class into 6 groups and call the groups Who, What, When, Where, Why and How. Label each group's piece of butcher's paper in the same manner.
- Now read the stimulus letter on the page opposite or the one you have selected. In reading the article, you must be able to extract the facts and then organise them so as to truly evaluate the article's worth.  
This activity will show you how this can be done.
- Select a piece of butchers paper for your group.  
It will be labelled either: Who?, What?, When?, Where? or How?

### Materials and equipment (per group)

- 1 sheet of butcher's paper
- blue tack
- marking pen

<b>5W+H</b> Who What When Where Why + How
---

- As a group, your task is to select and write down 3 questions arising from the article.  
The following is an example:  
Who wrote the article? (an example of accuracy in comprehension).  
Who is the author addressing the article? (an example of interpreting comprehension).  
Who do you believe is right? ( an example of applying the comprehension - you will need to defend your opinion at this level).
- When your three questions are complete, blue tack your paper to the wall for other groups to view.
- Move around the room now and answer all the questions.

---

---

---

---

---

---

---

---

---

---

---

---

---

---

---

---

---

---

---

---

---

---

---

---

---

---

---

---

---

---



# ANGLERS NEED TO ALTER THEIR WAYS

As an amateur fisherman with a long standing commitment to nature conservation, I am concerned at the extreme action by fishing clubs and others to the action taken by Environment Minister Mary Robinson to provide a resolution period in which the future of fishing in certain national parks can be determined.

It seems that the strength of this reaction will now ensure that reasonable consultation and careful consideration of the issue will not happen.

I recognise the strength of the reaction is indicative that many communities have strong cultural ties with amateur fishing and with localities in which fishing occurs.

Surely though it is time for us to accept, as we have with the Great Barrier Reef Marine Park, that there should be areas zoned for a range of activities and that some zoned areas of total

protection should be included.

If the views expressed so strongly are typical, then I wish to distance myself from my fellow anglers on this issue. I believe that it is time to highlight the impact which amateur fishing has on the environment, mostly because a vast majority of us do not care or cannot recognise the degradation we are causing.

It is obvious that popular fishing destinations are usually the most disgustingly littered sites, with everything from food and bait packaging to broken crabpots.

The telltale signs of direction taken by wildfire anywhere along the Queensland coastline show that a disproportionate number of fires have originated from beach or mangrove areas. Invariably these are fisherman's cooking fires or smoke fires lit to reduce the biting insects.

The growing number of silver gulls in well used areas

are a threat to the future of nesting birds of other species such as terns.

How many fisherman recognise that their careless handling of bait and fish carcasses has been the primary cause of the gull explosion?

Overpowered boats roaring up shallow estuarine breeding grounds and throngs of four wheel drive vehicles which crunch over the eggs of beach nesting terns, oyster catchers and plovers are other features of this fishing scene.

The amateur fisherman is just as much to blame as the professional for the accidental impact by boats on turtles and dugong and the disruption of feeding and breeding grounds of these species.

Unless anglers learn to minimise their impacts and be less greedy in their capture of freshwater and marine life, the need for increasing legislative constraints will escalate.

Figure 142.1 Stimulus article

---

---

---

---

---

---

---

---

---

---

---

---

---

---

---

---

---

---

---

---

---

---

---

## 4.34 Should Whale Bay have a marine protected area?

Based on an original by Jan Oliver and reprinted from *Marine Studies for Senior Students* 1992 (now out of print)

### Aim

To have students play a simulation role play game to answer a question - Should Whale Bay have a Marine Protected Area?

### Objectives

Teachers should be able to

- provide students with opportunities to apply some of the principles of management and conservation;
- enable them to use decision making procedures;
- enable active participation using roles not necessarily familiar to them;
- further develop group and communication skills;
- provide a further enjoyable experience as part of their learning programme on coasts;
- appreciate the need for conciliation, conflict resolution, debate and informed discussion over planning issues.

### What you need

- A large room, preferably with notice boards or walls suitable for displaying maps, posters etc.  
This room will be used for the final presentation, so needs a desk in front, with an OHP or data projector, some other desks at the front for reporters and secretary, and then chairs arranged for the rest of the players in rows as in a public hall.
- Sheet A - About Whale Bay (see opposite)
- Sheet B - Instructions (see page 196)
- Sheet C - Proposed zoning plan colour map (see page 197)
- Sheet D - User groups proposed plan
- Sheet E - Role slips (pages 197 - 204). Use a pair of scissors to cut these up and distribute.
- Reference books or leaflets on whales, dive sites, coral reefs, tourism, should be available. Suitable ones are obtainable from your State Department of Environment or equivalent, (including Annual Reports); Commercial Fishing organisations (the States' organisations publish their own Journal and supply back copies for schools); Great Barrier Reef Marine Park Authority in Townsville, Queensland, (e.g. Reef Notes: 'Whales', 'Coral Reefs', 'Dugong', 'Fishing';) and libraries, including municipal (for books on mangroves, dugong, whales, fishing methods etc.)
- Supplies of OHP transparencies or compute and powerpoint, pens; felt pens and butcher or other large sheets of paper.
- Players may wish to appear in appropriate dress for their roles, and as this is certainly part of the fun, it should be permitted if possible.
- Outside personnel may be used for information briefing - for example, a planner, a conservationist, or local whale or wildlife expert; other teachers may also have expertise which is useful and can be called in as consultants.

### Time required

To organise, prepare, plan, brief, deliver, debrief and evaluate, the game takes about two weeks. However it can be shortened as follow:-

#### Lesson 1

- Role draw, briefing, sorting out of groups, and initial research.

#### Lesson 2

- Continuing research, display of posters and advertisements, preparation of roles and sorting out sequence of appearance.

#### Lessons 3,4

- Double period - Presentation of groups zoning plan

#### Lesson 5

- Voting. Summary by Chairperson, Media presentations
- Debriefing by teacher.

This type of game also works very well at camps or at the end of the course, and could be used as a total theme - the students 'play' their roles in costume for days and nights rather than merely in the lesson time.

Outside experts can also be brought in, and sites visited to give a sense of reality. The presentation then becomes a major item of programming and can take several hours!

### Why the game

- This is the end of the course. Hopefully you have the knowledge about boating, diving, marine biology, oceanography, conservation and management to play the game.
- It is open ended to a large degree to give groups the freedom to modify the characters and events to suit the local issues.

# Sheet A - About Whale Bay

Whale Bay occupies the area between a large island, Wallaby Island, and the mainland somewhere in Australia.

On one side, its mangroves and wetlands fill most of the channel, and some of these are Fish Habitat Reserves where fishing is prohibited, some bait collecting occurs along the mud. The eastern side is open to the ocean, and has deep clear water. Close to the western shore grow hectares of seagrass, which support nearly 1000 dugong, the marine sea cow. Several species of turtle live and feed in the Bay and some nest on the sandy shores to the north. Pirates used the Bay in times past, and wrecks of ships sailing too close to some of the rocky shores lie on the sea bed. These provide fascinating dive spots and coral reefs with soft corals, feather stars, numerous molluscs, worms and fish. The Bay is considered to be one of the best dive sites in the State. It also supports twenty trawlers and an active recreational fishery. The fish are off loaded at the fishworks in the small township of Whale Bay on the western shore and some are frozen for the capital city markets.

The Bay's newest arrivals are the Humpback Whales who have been moving into the Bay to rest en route between their summer feeding grounds in the Antarctic and their winter breeding grounds in the waters of north eastern and north western Australia. Whales are seen in the Bay from late May to June and on the return journey between August and October. Many are up to 40 tonnes and up to 15m long. On the return journey from the warm waters, most of the females are accompanied by their calves born up north.

Thousands of visitors crowd into charter boats to visit the Bay in the hope of seeing the whales swimming close to the surface or diving or leaping out of the water ("Breaching"). The whales only feed in the Antarctic Ocean and consume enormous quantities of krill, tiny crustaceans. Whale scientists and conservationists are getting alarmed that the great mammals will become pressured by the increasing numbers of whalewatchers, all crowding together in Whale Bay. The whales may then move away from the Bay altogether. There has to be a reasonable management approach so that tour operators and visitors could still use the resource, but that at the same time, the whales would not be hindered in Whale Bay. Regulations are already in place and state that boats may not approach whales closer than 100m., and boats should

not break up groups or separate mothers and calves. Swimmers and divers are not to be closer than 30m. Rubbish or plastic may not be thrown into the water. The preservation of clean water in the Bay is also important for the whales' survival.

## The proposal

Officers from the State Department of Environment, and the Fisheries Department are also concerned that the whole Bay may be overused as a fishing resource and that divers, tour operators, trawlers and recreational fishing people all need more control.

The trouble is that people are used to having the freedom of most of Whale Bay, which has been used for fishing for a hundred years.

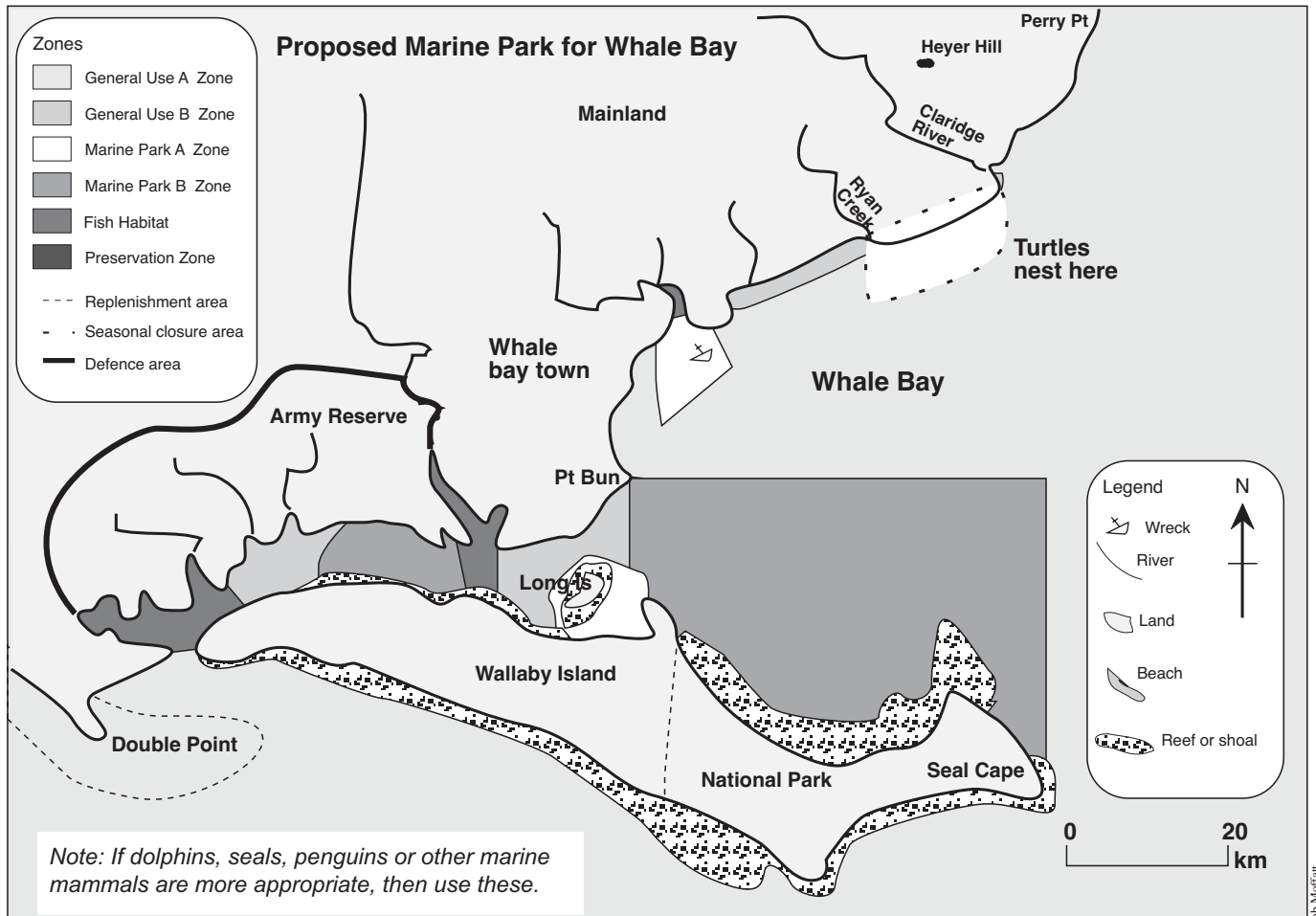
Two Fish reserves (marked on Map) have been established in the last ten years. For years, the hinterland behind Whale Bay was sparsely settled, but in the past twenty years, more farmers have cleared the land, and keep cows, grow hay, lucerne and vegetables and flowers for the cities. The Army also owns much of the land to the west and has retained all of the natural forest, bush and mangrove cover.

A Marine Park is proposed, which would divide the Bay into various zones where whales could be viewed, fishing occur, dugong, turtles and other marine life be left in peace as outlined in the map below.

It is also considered important that a Preservation Zone be made where no one should enter so as to conserve the natural environment as it is now. It could be noted that the zones are not as complex as those used in the Great Barrier Reef Marine Park.

The borders of the proposed Marine Park and the zones are shown on the Map. The State government has asked for public submissions on the Park proposals. A public meeting has been called as part of the consultation process which the State government (through the Department of Environment) is anxious to see in operation. If certain groups or individuals put up a strong case to change the boundaries or the zones, then the meeting can recommend this and the Park will be altered.

Consideration has to be given to all the users of the Bay, but, at the same time, the long term conservation of both the Bay, with its clear waters, its marine life and its surrounding mangroves, sand dunes and rocky shores, has to be given equal weighting. There will be no whales, turtles, dugong or fish if the marine environment is not cared for.



## Sheet B - Instructions

### Objective

The objective of the Game is to decide if a Marine Park should be declared in Whale Bay, how big this Park should be, which boundary is best, and which zones should apply.

Principles of conservation and planning should be applied as required. Zones for different users have been proposed and these have to be talked about and decided at a Public Meeting which the Shire President has called.

### Groups to be formed and roles to be played

Five groups of people as listed in table 1 opposite, have to assemble together, collect information and decide how they stand on the proposal.

You will have two lessons to prepare and sort out your case, to prepare the summary and to decide who will speak.

### Public meeting presentation

The public meeting will probably take another two lessons, with the voting and summing up in another.

- Before the public meeting begins, the reporter and TV crew show a news item that has been prepared with an interview with the chairman
- Presentations at the meeting may influence groups to change their minds, and the individual voting at the conclusion should give an indication of the community's views.
- Some individuals will speak at the meeting, and some will represent the major groups.
- The order of speaking and time allocated to each speaker will be decided by the Chairperson, and advertised.
- Everyone must agree that the Chairperson keeps the meeting in order.
- Everyone will need to research as much information as necessary to be prepared for questions and reactions at the meeting.
- Unless the Chair decides otherwise, you may not interrupt speakers, though may be allowed to ask questions afterwards.
- Maps may be prepared, and summaries of the key points presented to the Secretary by you or your group before the meeting commences.
- Be prepared to be interviewed by the media and by the Chairperson who may want to see how viewpoints are developing.
- The Chairperson will sum up at the end. Then everyone has a vote as to the proposal and votes in their own role. The results will be published in the local newspaper.
- At the finish of the Game, your Teacher will ask for your opinions as to how it all went and the media prepare a TV segment for the evening news.

### Who wins the game

Hopefully everyone is satisfied and everyone goes away a winner.

### Debriefing

Students are asked for their opinions as to how the game went, what they thought of their roles, and what they think about the Marine Park. Would other factors need to be considered for the Park? What did they learn about procedures and management principles? (Be prepared for criticism!)

If students have never played a role play game before, some may not appreciate their roles, or felt they did not have a chance to perform. On the other hand, many will find the Game a most worthwhile experience and will wish to do more.

Finally make sure you get out of your role so you don't carry it around for the rest of the school year!!!!

**Table 1: Game groups and roles**

#### Group A

- Dive shop owner
- Hardware shop manager
- Cafe operator
- Whaler Arts craft shop
- Commercial fishermen's delegate

#### Group B

- Professional trawler operator
- Army officer
- Aquaculture farmer
- Tour boat owner

#### Group C

- Scientist
- National Parks service officer
- Whale Conservation Society
- Wildlife Preservation Society
- Bush Action Group
- Department of fisheries officer
- Department of Environment officer

#### Group D

- Whaler real estate
- Recreational fisher
- Caravan Park owner
- Tourist developers
- University student

#### Group E

- Local residents parent
- Local residents
- A solicitor
- Herbalist
- Permaculture farmer
- Town planner

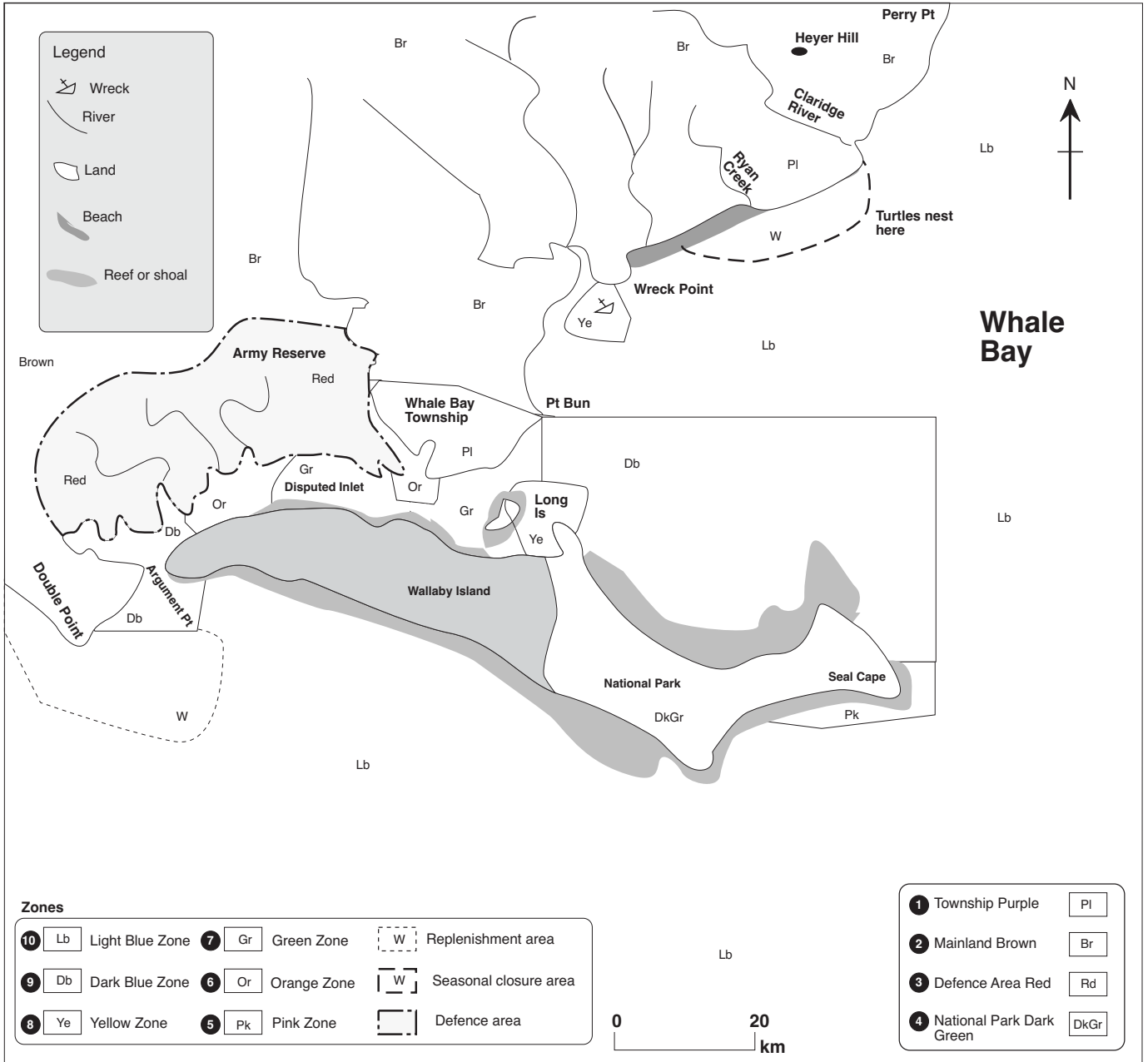
#### Individual roles

- Chairperson
- Secretary
- Reporter
- TV crew



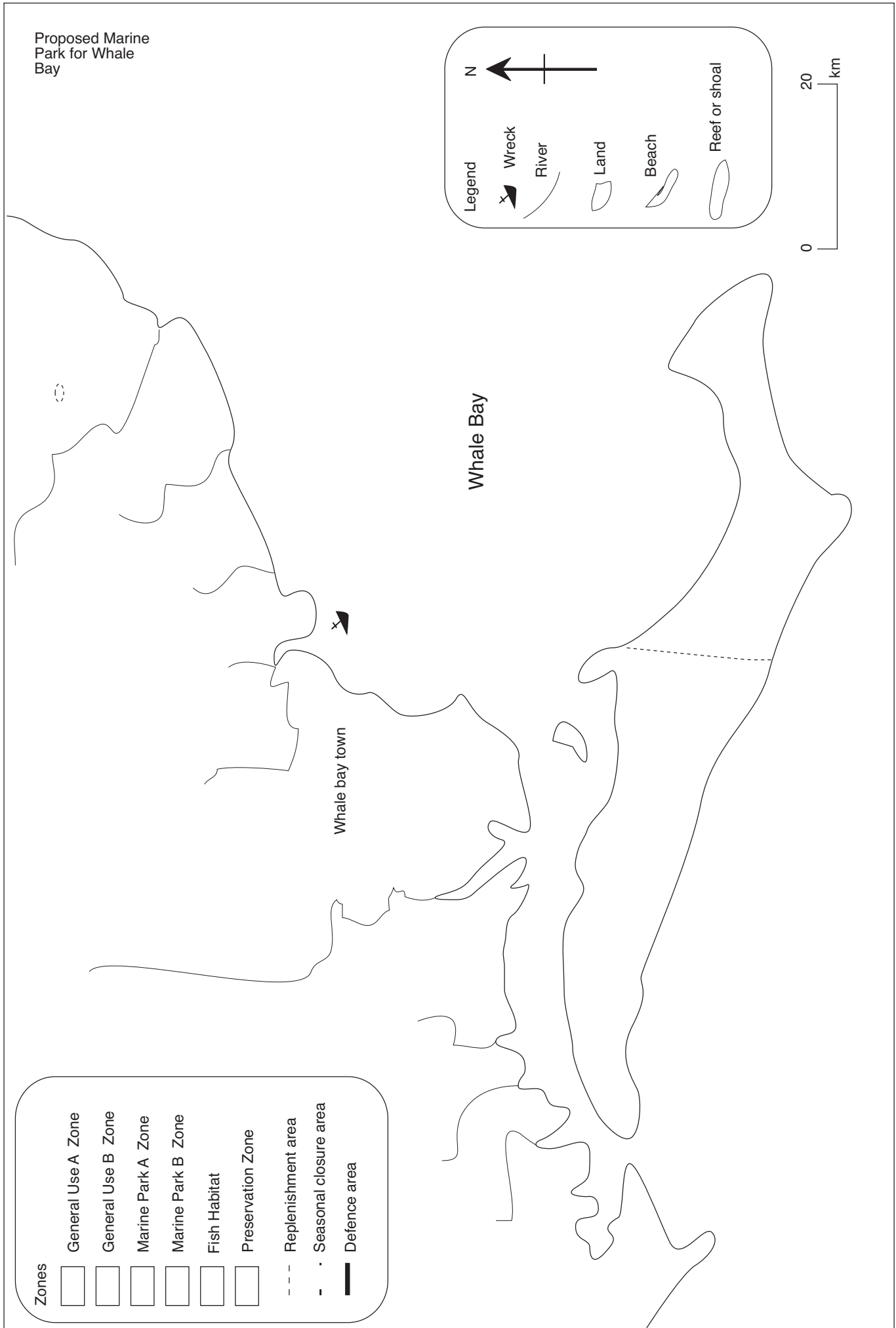
# Sheet C - Proposed zoning plan colour map

Use coloured pencils to create a colour version of the proposed zoning plan described in sheet A. You can modify this according to your local Marine Park zones and colours.



Permitted activities guide		Activities													
		Bait netting and gathering	Camping	Collecting (recreational not coral)	Collecting (commercial)	Commercial netting (see also bait netting)	Crabbing and oyster gathering	Diving, boating and photography	Line fishing (bottom fishing, trolling etc)	Research (non-manipulative)	Research (manipulative)	Spearfishing	Tourism and education (facilities and programs)	Traditional hunting (fishing and gathering)	Trawling
10	General Use A Zone <sup>Lb</sup>	Yes	Permit	Limited	Permit	Yes	Yes	Yes	Yes	Yes	Permit	Yes	Permit	Permit	Yes
9	General Use B Zone <sup>Db</sup>	Yes	Permit	Yes	Permit	Yes	Yes	Yes	Yes	Yes	Permit	Yes	Permit	Permit	No
8	Marine Park A Zone <sup>Ye</sup>	Yes	Permit	No	No	No	Limited	Yes	Limited	Yes	Permit	No	Permit	Permit	No
7	Marine Park B Zone <sup>Gr</sup>	No	Permit	No	No	No	No	Yes	No	Yes	Permit	No	Permit	No	No
6	Fish Habitat Zone <sup>Or</sup>	No	No	No	No	No	No	No	No	Permit	Permit	No	No	No	No
5	Preservation Zone <sup>Pk</sup>	No	No	No	No	No	No	No	No	Permit	Permit	No	No	No	No
	Replenishment Zone <sup>W</sup>	No	No	No	No	No	No	No	No	Permit	Permit	No	No	No	No

Sheet D - Proposed plan by



Proposed Marine Park for Whale Bay

**Legend**

- Wreck
- River
- Land
- Beach
- Reef or shoal

N



**Zones**

- General Use A Zone
- General Use B Zone
- Marine Park A Zone
- Marine Park B Zone
- Fish Habitat
- Preservation Zone
- Replenishment area
- Seasonal closure area
- Defence area

Whale Bay

Whale bay town

## Sheet E - Role slips for participants

The number of roles needs to be adjusted for the number of students.

If a smaller group is playing, then the teacher should make a selection of which roles to omit. If more students are playing than the available roles, it should be possible to duplicate some roles without affecting the objectives or outcome of the game. Roles most easily and usefully duplicated or removed are indicated.

### **Role slips - see over**

(use scissors to cut up and distribute)

These need to be copied onto cards or paper, then placed in a container from which each student draws one role. A record should be kept of students and each role so that no one is tempted to swap roles!

Even if it appears that a student draws an incompatible role, it is amazing how well all perform given the opportunity.

Everyone is then given the instructions (Sheet B) and the rules explained. If the class is large, it is much easier if similar roles are grouped together and one representative from that group contributes directly to the presentation of the final game, with assistance from the others (this is, of course how things happen in reality). Groups are indicated on the role cards.

Next, depending on time, each group meets together and plans their strategy. Individual roles not in groups may either work on their own as an individual, or, visit several groups to get the feel of what is happening.

Groups and individuals need at least one lesson of preparation about Whale Bay (see sheet A) and the content of the game .

They can be provided with transparent OHP sheets and pens to prepare major points, or a map. Several players are required to place notices or posters around the room (on large sheets of paper) and space should be allowed for this. The Chairperson and Secretary decide on appropriate sequencing of presentation at the Public meeting, and put a notice to this effect. Groups and individual players decide what they are going to say and how. Dressing ups are collected.

On the day of the game, enough time must be allowed for cleaning up! Two lessons should be allowed for presentation, with the chairperson keeping a strict eye on the time (assisted by the teacher if required).

The Chairperson sums up at the end (usually the next lesson). All students cast a vote in their roles as to the best Marine Park. To conclude, it is essential that the teacher de-brief the students.

Do not forget....this is all meant to be fun!

### **User groups**

Note: Those \* can be increased. Those # can be eliminated.

Groups are merely indications only. One or more from these groups should present viewpoints at the meeting. Other groups may be used. Individuals not in groups have to present their view at the meeting (except Media and the Chairperson and Secretary). The Chairperson may need assistance from the teacher in controlling the meeting but often can cope alone.

• Chairperson	1		• Whale Conservation Society	1	Group C
• Secretary	1		• Wildlife Preservation Society	1	Group C
• Reporter	1 *#		• Bush Action Group	1#	Group C
• TV crew	1*#		• Department of Fisheries Officer	1	Group C
• Dive shop owner	1* Group A		• Department of Environment Officer	1	Group C
• Hardware shop manager	1# Group A		• Whaler real estate	1	Group D
• Cafe operator	1# Group A		• Recreational fisher	1*#	Group D
• Whaler Arts	1# Group A		• Caravan Park owner	1#	Group D
• Commercial Fishermen's delegate	1 Group B		• Tourist developers	1*	Group D
• Professional Trawler operators	1* Group B		• University student	1	Group E
• Army officer	1 Group B		• Local residents parent	2	Group E
• Aquaculture farmers	2* Group B		• Local residents solicitor*	2	Group E
• Tour boat owner	1* Group B		• Herbalist	1#	Group E
• Scientists	2 Group C		• Permaculture farmer	1*#	Group E
• National Parks Service Officer	1* Group C		• Shire Town Planner	1	Group E

### **Chairperson**

Your role is to chair the public meeting and to keep order so that everyone who is supposed to speak gets a chance to do so. You can draw up a time table. The Secretary will assist you to gather information about each of the groups and individual players so that you have some idea of how people are thinking.

You have to sum up at the end of the Game, and supervise the voting at the end. You are the Shire President so you are used to being in charge but are good at keeping control. You know this is an important occasion so would wear formal clothes.

Before the meeting, you have to record a interview with the local reporter and TV crew.



---

### **Secretary**

You need to keep records of what is happening both before and at the meeting. You could get each spokesperson to summarise the group major points before the meeting for you; help the Chair to draw up a time table and prepare a poster showing this; you should also prepare a poster announcing the meeting time.

At the meeting, you could record the speeches and list the main points of the speeches on an OHP or board as the meeting proceeds to help the Chair prepare a final summary. You are well known for your attention to detail and your clothes tend to be fussy. You are worried about losing your glasses so always wear at least two pairs around your neck on strings.

You are to prepare press release on the meeting for the Chairpersons media interview.



---

### **Reporter**

Your role is to get a good story on both the preparations and the actual meeting. Your newspaper covers the whole region of Whale Bay and is read by everyone. You like getting the REAL facts, including clash of interests between the groups. You can prepare a 'Wall Newspaper' which contains 'Daily' News' as the groups start work. You could interview key players before and during the meeting. Prepare a final News Report after the meeting and then give the news of the voting. Check other newspaper reports to see the style used in reports about planning and conservation issues.

You wear casual clothes and always carry writing and recording equipment. You will work with the TV Crew.

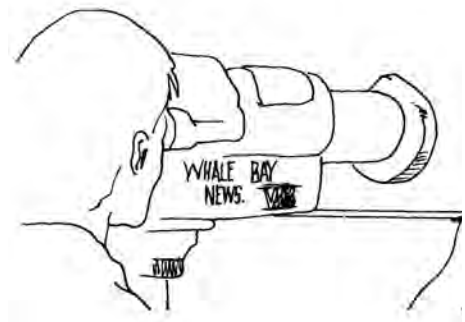


---

### **TV crew**

Your local television station carries news around Whale Bay and you need a good drama to catch everyone's attention. You need a portable video camera to record the groups preparing beforehand, and to shoot the actual meeting. Work with the reporter and interview key speakers and any clashes.

You would also record the map and other pictorial matter if available (in close up). (Get assistance from your school AV Officer if required). You wear a T-shirt with a round logo and '15' inside to represent Channel 15.





**Dive shop owner**

You own and operate the local dive shop in Whale Bay and wear casual sports clothes and a dive watch. You take groups of divers into Whale Bay to view the coral, rock formations and marine life (including dugongs, turtles and fish) as well as the wrecks offshore.

Your business is struggling and you have huge repayments on your boat. You want major areas of the Bay restricted to fishing as you think fishing is both depleting stocks of fish and causing damage to turtles and whales through entanglement in nets, lines, ropes and plastic bags. You dress casually, a fitness freak and can't stand people who are flat and unmotivated.



**Recreational fishers**

You have retired from the Shire Council (where you were a road ganger) and spend your time fishing in Whale Bay. You like seeing the whales coming back into the Bay, but you want to have enough fish to catch and peace and quiet - anything for a quiet life.

You always object when you hear people having arguments because it's not worth it is it? As the Bay already has several Fish Reserves you think more regulations are just being put up by the government to control everything, so you strongly object. You always wear casual clothes, no shoes, and a hat. You are overweight.



**Tour boat operator**

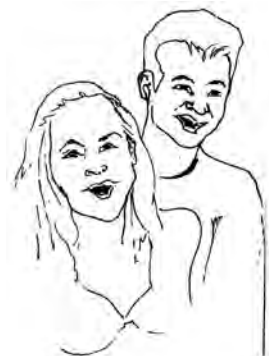
You own a large fast boat "StarTrek 4" and take groups of tourists out to see the whales during the northern and southern migrations. You like to get your boat as close as regulations permit. You have been making a lot of money lately and want to see your business thrive, so don't want any controls which would prevent you taking your boat out and into the whole Bay. However, your livelihood depends on whales so you want their areas protected, so long as you can get into them! You always wear a hat, white clothes and carry a bag of emergency supplies. You have a million dollar loan on your boat with repayments of \$4,000 per week.



**University students**

You always take your holidays around Whale Bay and your family still live there. You are studying marine science and feel strongly that the Bay needs more protection. You have been on fishing and boat trips and are horrified at some of the damage you see being done to the Bay.

You are also keen to be an objector and to join in any protest (with banners) the conservationists or others might organise at the meeting. You have long hair, never wear shoes.



**Whaler arts**

You run the local arts and craft shop and encourage local artists to provide pottery, paintings and knick-knacks. You are a good artist yourself, and specialise in wildlife paintings. You would like more protection of the marine and other life in the Bay and strongly object to fishing, hurting wildlife and noisy boats. You always carry brushes and paint and paper in case you see a good subject.



**Commercial fishermen’s organisation officer**

You spend your time talking and talking about fishing and Parks, and want to see commercial fishing people with good access to their traditional fishing grounds. You have accepted that you need to talk with conservationists but think everyone is pushing ‘nature’ too much. You have already agreed to the regulations controlling the size of nets, where these can be placed and where trawlers can go. You are not prepared to see most of the Bay a restricted area. You wear a beanie, old clothes and bare feet.



**Hardware shop manager**

Your Whale Bay Hardware sells fishing, diving sports and camping equipment and you are doing well with increased tourism. You don’t wish to see your business drop if too much of the Bay was closed to tourists or fishing. You wear work clothes, always carry a tool box or bag and are inclined to fix up things all the time.



**Cafe operator**

Your cafe faces onto the Bay and your little tables and chairs are well used by locals and tourists wanting devonshire teas and your home made jam. You want tourists to continue and don’t feel strongly about the new Park proposals so long as your cafe continues. You always wear an apron, carry a basket of jam, and have been known to lose your temper and throw scones at people who argue against you.



**Whaler real estate**

You are the local land agent and are developing new blocks for sale to the tourists you are hoping will move to the Bay. You want to see a mix of Marine Park and fishing as this will allow all groups to stay. You always wear flowery clothes and have a pushy manner.



Role sheets - copy, cut up and distribute

**Local residents**

You are a parent with two children and have just built a home. You are very conservation minded and are conscious of climate change and global warming. You have a native garden and grow your own organic vegetables.

You want to see a nice environment for the children to grow up in, and will fight to see that achieved.

You are not really sure of how this will be best achieved so are prepared to change sides. You carry your youngest baby (a doll) and supplies of nappies, pins etc.



**Scientist - migrators bird expert**

You are a well known Australian expert on migrators birds and have just completed your PhD. You know lots about their food, sea grasses, and know that the sea grass beds are only found on the northern (mainland) side of the Bay close inshore.

Whale Bay is the only site of one of the sea grasses *Halophila ovalis* in the State, and the only site where migratory birds can rest. You are very keen about saving the seagrasses and am urging the state government to declare a RAMSAR site. You wear binoculars and dark glasses all the time.



**Professional trawler operator**

You own the Whatsit, a trawler operating in Whale Bay. You are sick of being told what to do: you have had to change the size of your nets, where you place them, and are worried that restrictions are going to be placed so that you can only fish 5 km offshore. You want 1 km off shore fishing as that is where most fish are. You are sorry that dugongs, and turtles get tangled in your nets, but if lines and ropes and plastic bait bags fall overboard, well, that's life and you have to make a living. You wear shorts and old sneakers, and a very old hat.



**Scientist**

You are a researcher on turtles in Australia and have tagged many on the ones living in Whale Bay for over twenty years. There are two groups using the Bay - local Hawksbill, Green and Loggerhead Turtles live in the Bay and feed on grasses and shellfish, and nest further north. Another large group of Loggerheads (which are endangered) nest on the shores of Whale Bay. You are cautious about any more tourists coming to visit the area as they disturb the nesting turtles but you realise that turtles are interesting and of course, you are fascinated by them.. You always carry a torch, notebook carry pictures of turtles to show people.



### **Tourist developer**

You own a lot of land around the shore, and want to see tourism get going with a bang. You spent a lot of time in the United States looking at hotels, motels and marinas and are keen to see a 'Whaler Wharf', more shops, more boats and activity in Whale Bay. You know that the whales have to be protected as they are the draw card for tourists, but after all, everyone has to make money. You detest conservationists, hippies, anyone unusual, and say so. You have picked up a few American mannerisms, and wear very bright colours.



---

### **Permaculture farmer**

You are one of the group growing organic food in a small farm along the creek running into Whale Bay. You are well aware of the pollution farms can cause and as you love animals you want to see the best possible deal for whales, dugong and turtles.

You therefore go for regulations on fishing though you think everybody should get a fair deal. You don't have much time to think about clothes, and carry some of your healthy vegetables to sell or barter.



---

### **Local solicitor**

As the local solicitor, you have been asked to appear at the meeting on behalf of a number of local people who feel their side may not be well presented.

You want to see development continue around the Bay, but you are also concerned about preservation of the environment, and keep bees in your large bushy backyard.

You always speak calmly and logically, and wear a suit, but you feel the more protection the Bay gets, the better.



---

### **Whale bay trail bike riders club**

You represent the local trail bike riders club who love to bush bash on weekends and go pig shooting.

You don't really care about conservation or any ambition in life apart from having fun while drawing on social service payments. You wear a leather jacket and jeans, have an opinion on everything and think you are always right.



**Army officer**

The Army owns part of the foreshore of Whale Bay and has for years been carrying out training exercises in the bush, mangroves and sand dunes. You are also a keen diver and know the Bay well. The Army wants strict regulations over what will happen in the Bay and is keen to see a Marine Park in place with fishing very restricted. You wear Army gear and twirl your moustache.



**Department of environment officer**

You represent the Minister for the Environment and have to wait to see how things will go about all the proposals. The Plan was originally put up by you so you know a lot about it and try to persuade everyone to agree with it. You have a relaxed manner and wear relaxed type clothes especially when on these visits outside the capital city office.



**National parks and wildlife officer**

You have been at the Bay for two years and spend most of your time keeping tour boats away from whales, supervising the rescue of injured animals caught in plastic and in reporting pollution to your office. You think fishing needs to be kept well away from the marine life, and don't want any more tourists. You feel the mangroves, of which there are extensive stands, mainly *Avicennia marina* and the rarer myrtle mangrove *Osborna octodonta*. You usually carry wildlife books, always wear a hat, shorts and boots.



**Whale conservation society**

You are the representative of the organisation which specialises in whale watching, conservation and providing information to the public. You have travelled all over the world looking at whales and are very knowledgeable about them. Nothing should happen to these Humpbacks who are only just increasing in numbers after years of whaling operations. You would like the whole Bay as a Marine Park with no zones for fishing or entry, and you really like all boats kept away if possible too. You always wear binoculars and carry pictures of whales. You are madly in love with the National Parks Officer and tend get very romantic when that officer comes near.



**Wildlife preservation society**

You are the Project Officer at Head Office and you want to see the marine environment protected. You think that some of the locals are not aware of the importance of keeping all marine life protected in Whale Bay - the locals do not see the wider issues of conservation and management which you do. You have been trained as a botanist so want to see more of the mangroves protected. You have good skills in conflict resolution so you want to see everyone get on without too much fighting. You always wear shorts and boots, and carry environmentally friendly products.



### **Herbalist**

You grow herbs and organic plants in your backyard and all through your untidy house. You have been supplying herbal mixtures to everyone for years. You are a real gossip and take a keen interest in everything local despite your age (you are nearly 75). Your clothes tend to be a strange mixture, and you always carry plants and like to knit.



---

### **Caravan park owner**

Your life is dominated by the caravans, keeping them clean and full of tourists. You do not want to see a Marine Park as you think nature will take care of everything and people should not interfere. You are good at stirring up the locals and never go anywhere without your dog, your hat and a broom.



---

### **Bush action group**

You are the only group who will get action you think! You spend your life protesting, climbing trees, going out in small boats in front of trawlers and marching. You are good at scrawling graffiti and making posters, and like to make your views felt. In fact, you know you interrupt a bit much! You always wear t-shirts with messages, carry a sleeping bag and spare food.



---

### **Shire town planner**

You are the local planner from the Shire Council at Whale Bay and are a bit confused as to what the best thing would be. You speak very slowly and are knowledgeable about land use, but you don't know much about water in the Bay except that it is salt. You have never been in a boat, and are frightened of whales, turtles and anything that is connected with the sea. You never eat fish and avoid having anything to do with people who are connected with fish. You always stand with your hands in your pockets, speak with an accent, as you were originally from Europe. You are happy to see the Shire go ahead so don't mind tourists, developers etc. so long as they follow the rules.



---

### **Department of fisheries officer**

Your role is important as you know you have to bring together the opposing view of the conservationists and the trawler and tourist operators.

You have to issue permits and watch the regulations. You think the Bay probably does need more protection and want to get the fishing people agreeing to this without having to give into the scientists and conservationists. You are always busy so run around a lot, wear a white shirt with braid on it and feel important.



## 4.35 Images essay

Based on an original exercise by Tim Ryan, Maryborough State High School.

### Essay

What images does this cartoon give you when considering the immediate and future demands upon renewable and non-renewable resources?

Write a 200 word essay on the cartoon shown in Figure 207.1 using the following as a guide.

1. Describe the conversation between the fish and the dolphin that are washed up on the beach.
2. What do you believe could be the message in the bottle.
3. Suggest a reason why the planet is dying.
4. Describe how you would feel if you were the man sitting on the beach.
5. Which do you think has the most right to life on the earth, the dolphin or the fish?

In deciding, look at what each contributes and give reasons for your decisions.

6. You have just bought this island.
  - How would you manage the resources of the island?
  - What legislation might you develop to protect your island?

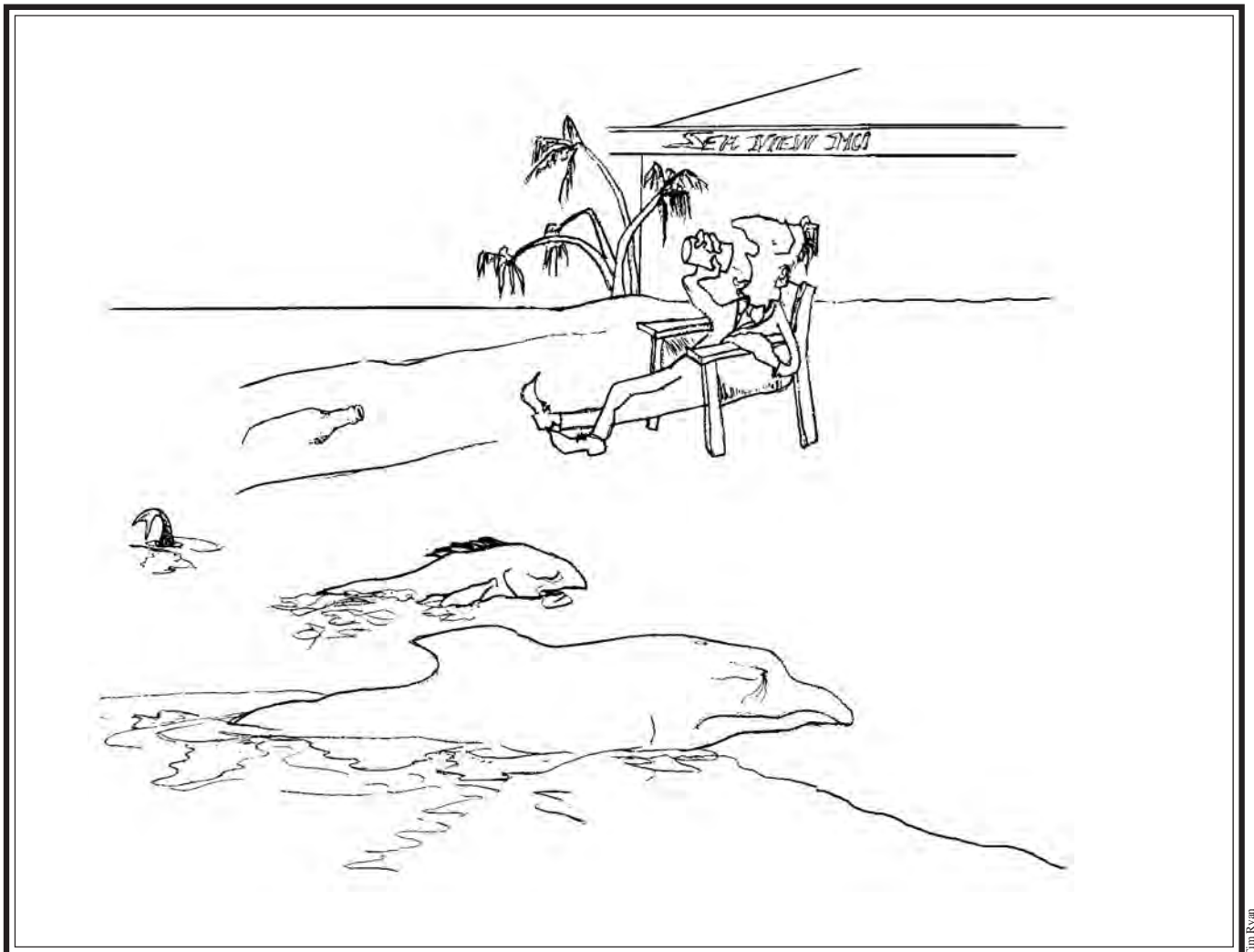


Figure 207.1 I wonder what the water is like?

## 4.36 Traditional management methods

Thanks to David and Graham Dillon from the Gombemberri Tribe, Gold Coast, for assistance in designing this activity.

### Questions and activities

Aboriginal and Torres Strait Islander communities often had a calendar by which they hunted.

1. Make contact with your local Aboriginal elders and go and see them about your school's interest in Aboriginal management methods.
2. Complete Figure 209.1 using elders from your local Aboriginal or Torres Strait tribe.  
Find out what type of management the local tribe used to practice.
3. Find out what you can and cannot write down and see if one of the tribe would like to tell some stories to your class.  
See if you can find out when the fish could be hunted and find out if there are any special ceremonies that the tribe would like to share with your school.
4. Ask if you could share in a class painting with traditional Aboriginal sea life like the one shown in Figure 208.1.

Find out if there are any local stories that can be told to explain how there was no division between land and sea.



Figure 208.1 Ideas for a natural events calendar. Border illustration by Ron Hurley, Gurang Gurang Tribe, Gladstone



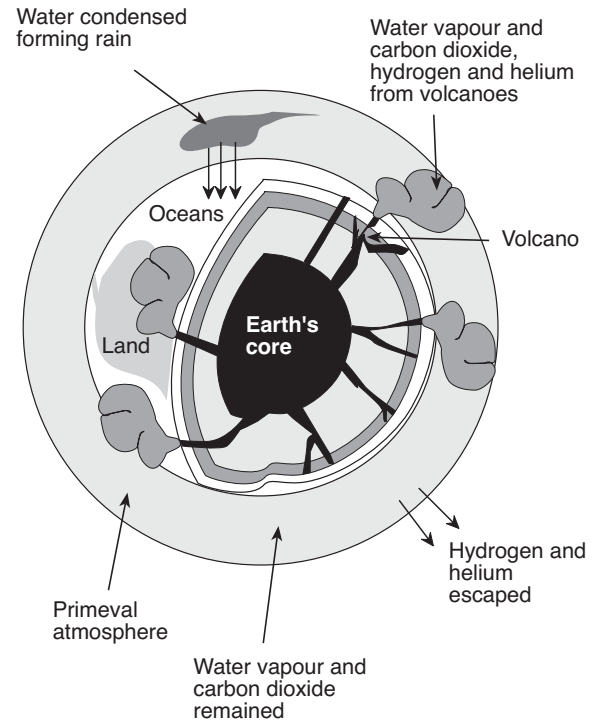
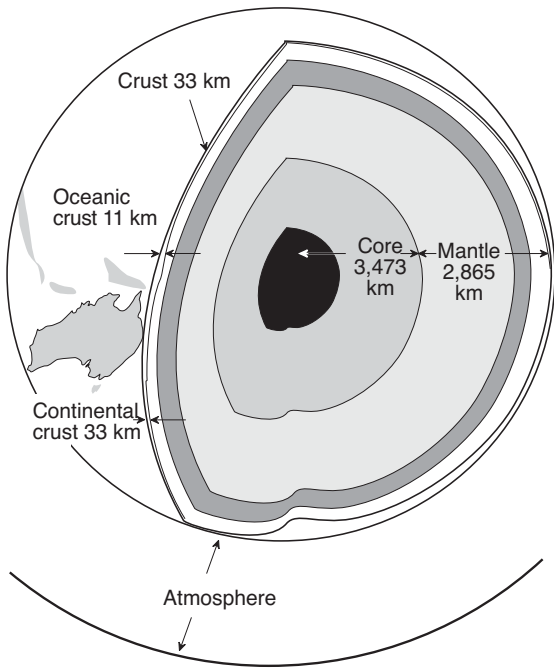
Figure 208.2 1990's Aboriginal elders, Gombemberri and Nunukle Tribes







# 5.2 Ocean formation



## Notes

---

---

---

---

---

---

---

---

---

---

---

---

---

---

---

---

---

---

---

---

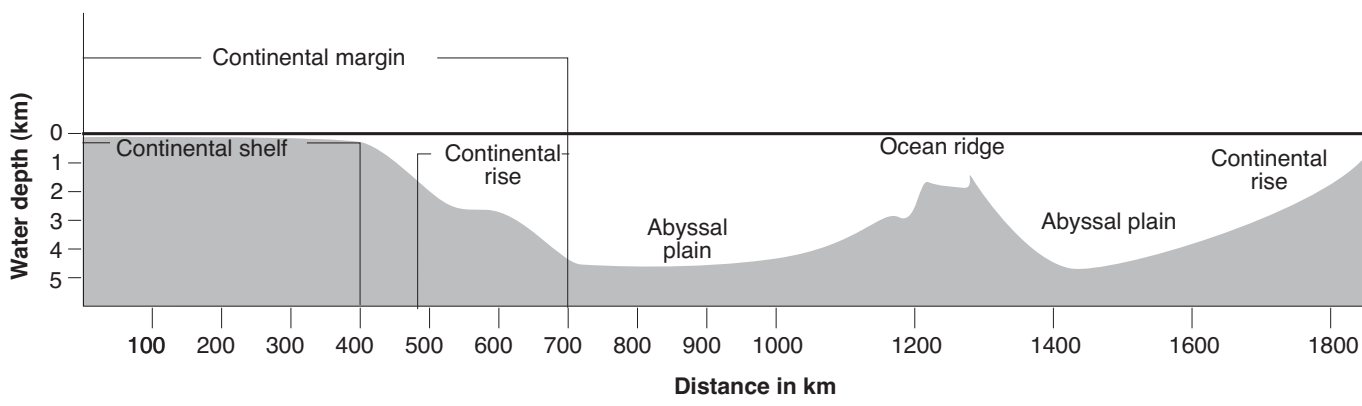
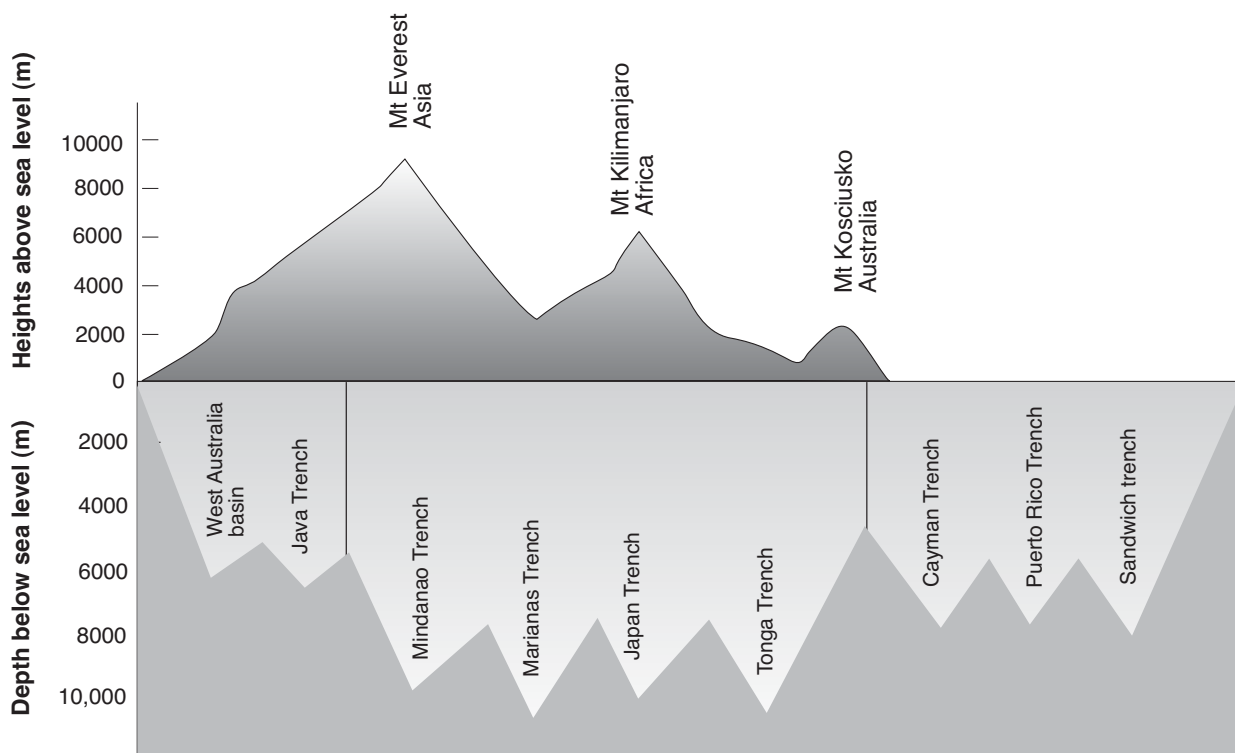
---

---

---

---

### 5.3 Ocean depth and topography



**Notes**

---



---



---



---

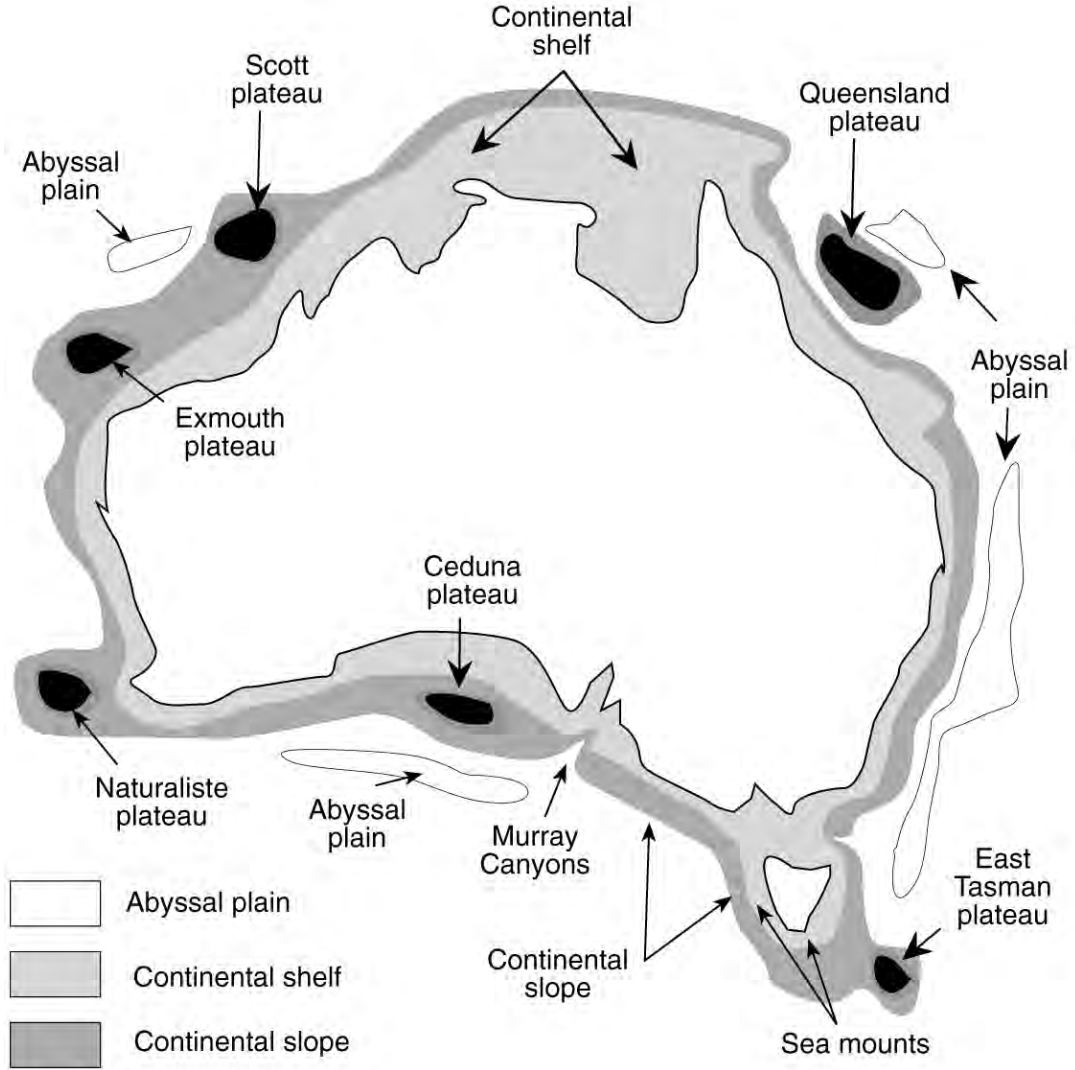


---



---

## 5.4 Australia topography



**Notes**

---

---

---

---

---

---

---

---

---

---

---

---

---

---

---

---

---

---

---

---

---

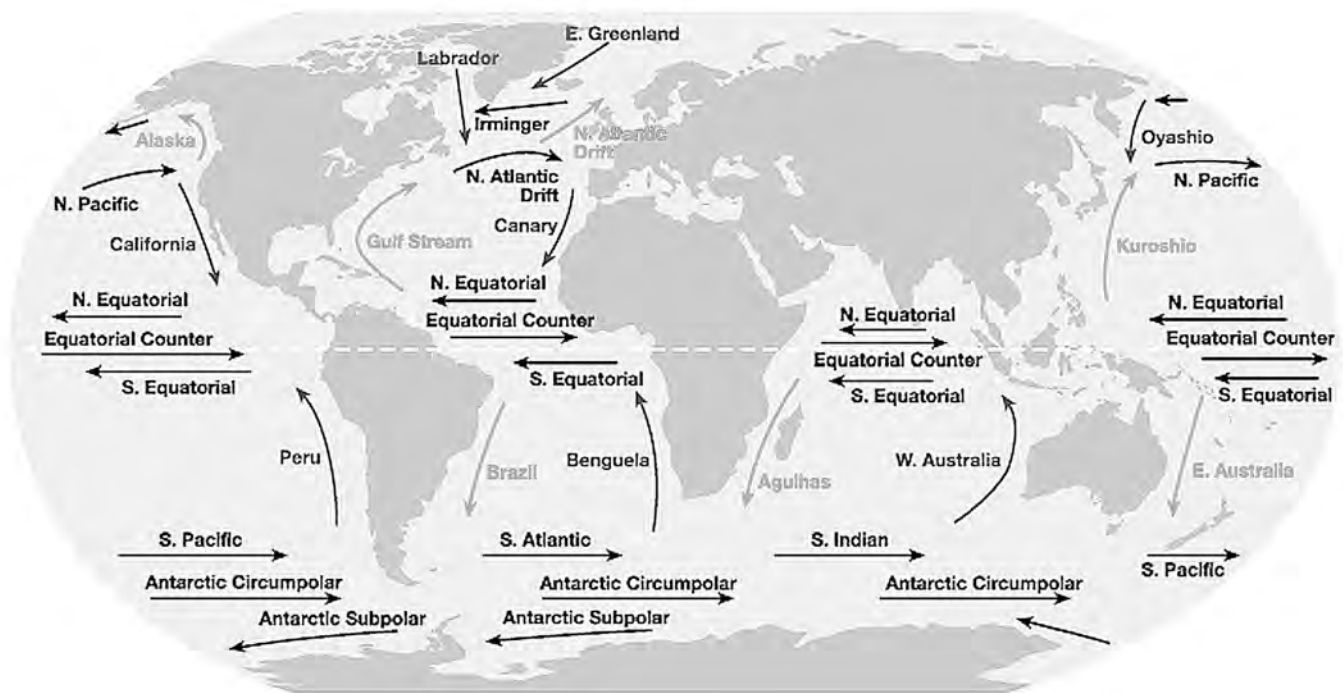
---

---

---

---

## 5.5 World currents



### Important currents

#### Arctic Ocean

- \* East Greenland Current
- \* Norwegian Current
- \* Beaufort Gyre (water or ice flow)
- \* Transpolar Drift (water or ice flow)

#### Atlantic Ocean

- \* Angola Current
- \* Antilles Current
- \* Baffin Island Current
- \* Benguela current
- \* Brazil Current
- \* Canary Current
- \* Cape Horn Current
- \* Caribbean Current
- \* East Greenland Current
- \* Falkland Current
- \* Gulf Stream
- \* Guinea Current
- \* Labrador Current
- \* Lomonosov current (a deep current)
- \* North Atlantic Current
- \* North Brazil Current
- \* Norwegian Current
- \* Portugal Current
- \* South Atlantic Current
- \* Spitsbergen Current
- \* West Greenland Current
- \* West Wind Drift

#### Pacific Ocean

- \* Alaska Current
- \* Aleutian Current
- \* California Current
- \* Cromwell current (a deep current)
- \* East Australian Current
- \* Equatorial Counter Current
- \* Humboldt Current (or Peru Current)
- \* Kamchatka Current
- \* Kuroshio Current (or Japan Current, Kuro Siwo)
- \* Mindanao Current
- \* North Equatorial Current
- \* North Pacific Current (or North Pacific Drift)
- \* Oyashio Current (or Oya Siwo)
- \* South Equatorial Current
- \* West Wind Drift

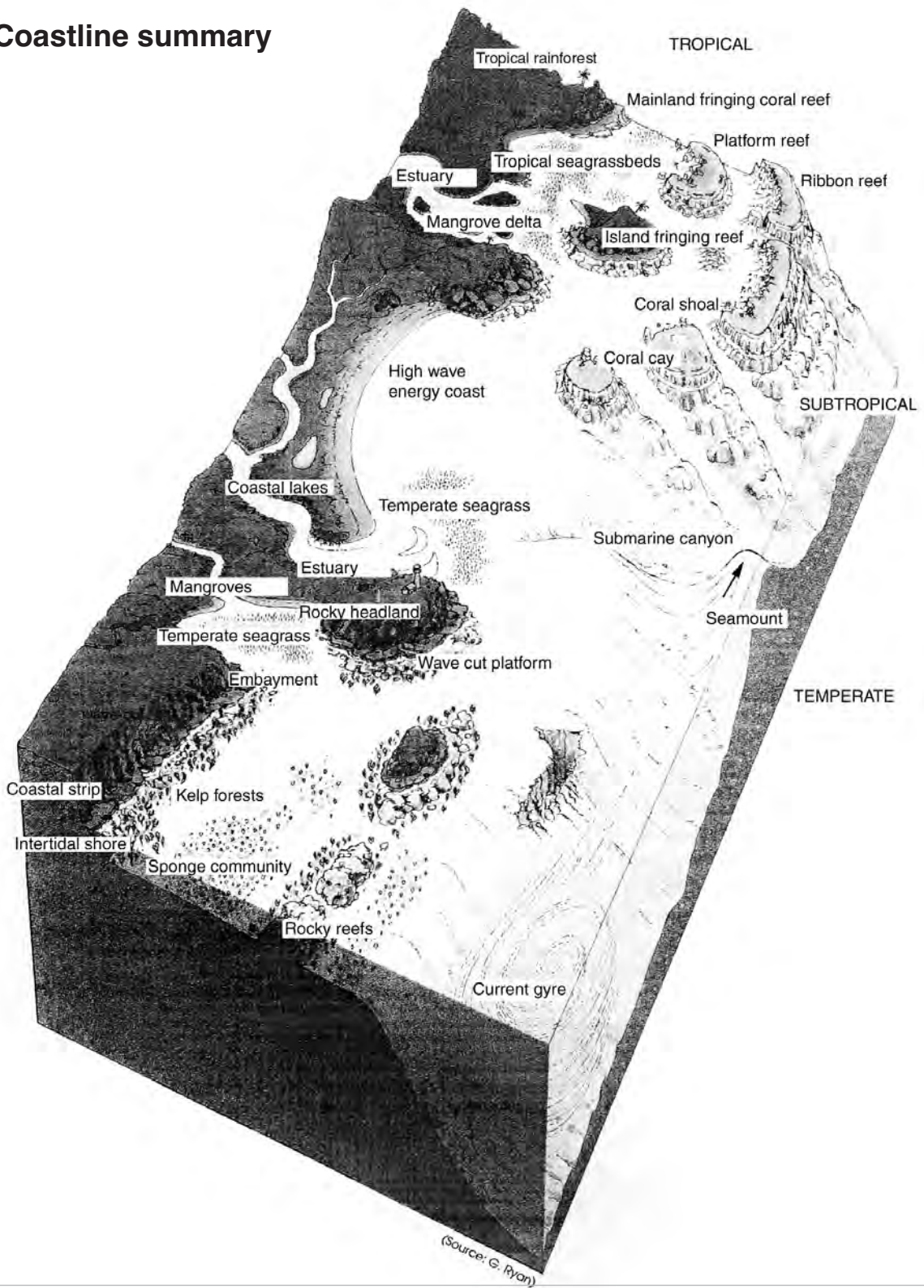
#### Indian Ocean

- \* Agulhas Current
- \* East Madagascar Current
- \* Equatorial Counter Current
- \* Indonesian Through-flow
- \* Leeuwin Current
- \* Madagascar Current
- \* Mozambique Current
- \* Somali Current
- \* South Australian Counter Current
- \* South Equatorial Current
- \* Southwest and Northeast Monsoon Drift (or Indian Monsoon Current)
- \* West Australian Current
- \* West Wind Drift

#### Southern Ocean

- \* Antarctic Circumpolar Current
- \* Weddell Gyre
- \* Tasman Outflow

5.6 **Coastline summary**



**Notes**

---

---

---

---

---

---

---

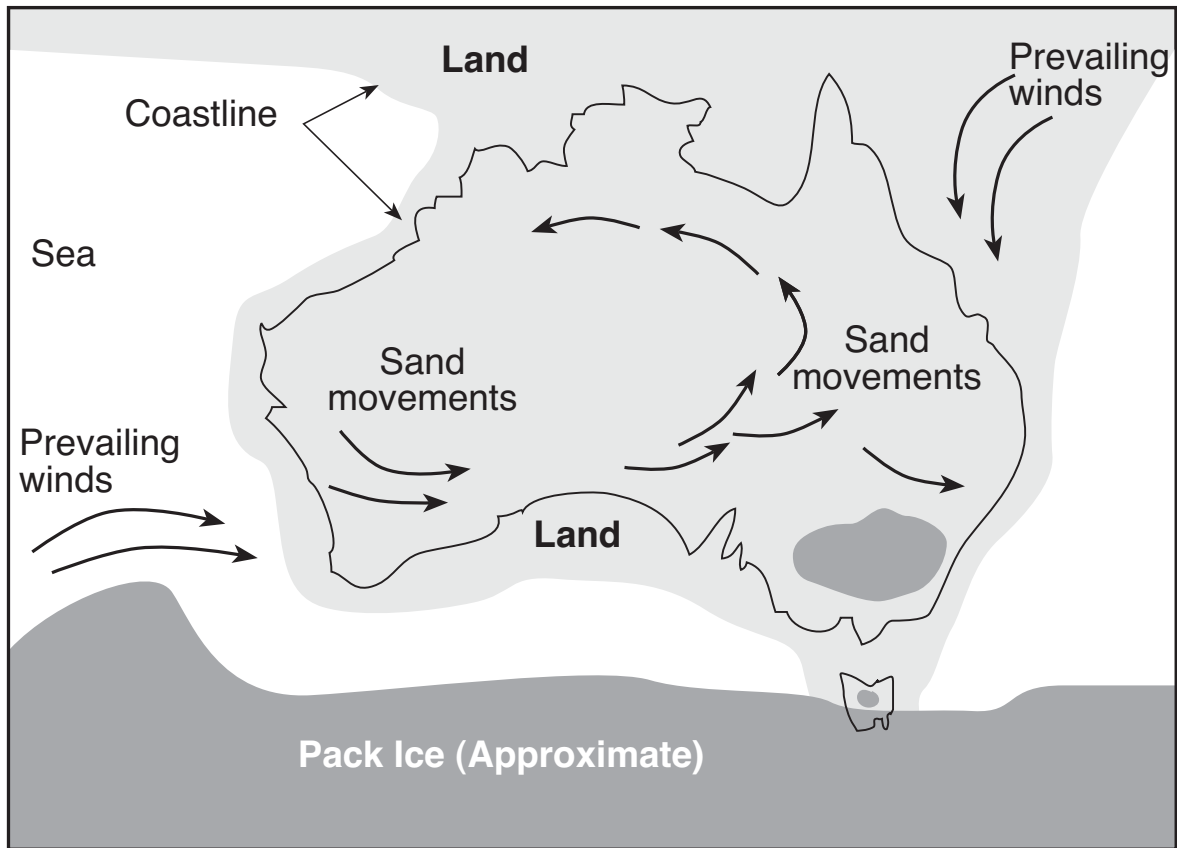
---

---

---

---

## 5.7 Ice age sand movements



### Notes

---

---

---

---

---

---

---

---

---

---

---

---

---

---

---

---

---

---

---

---

---

---

---

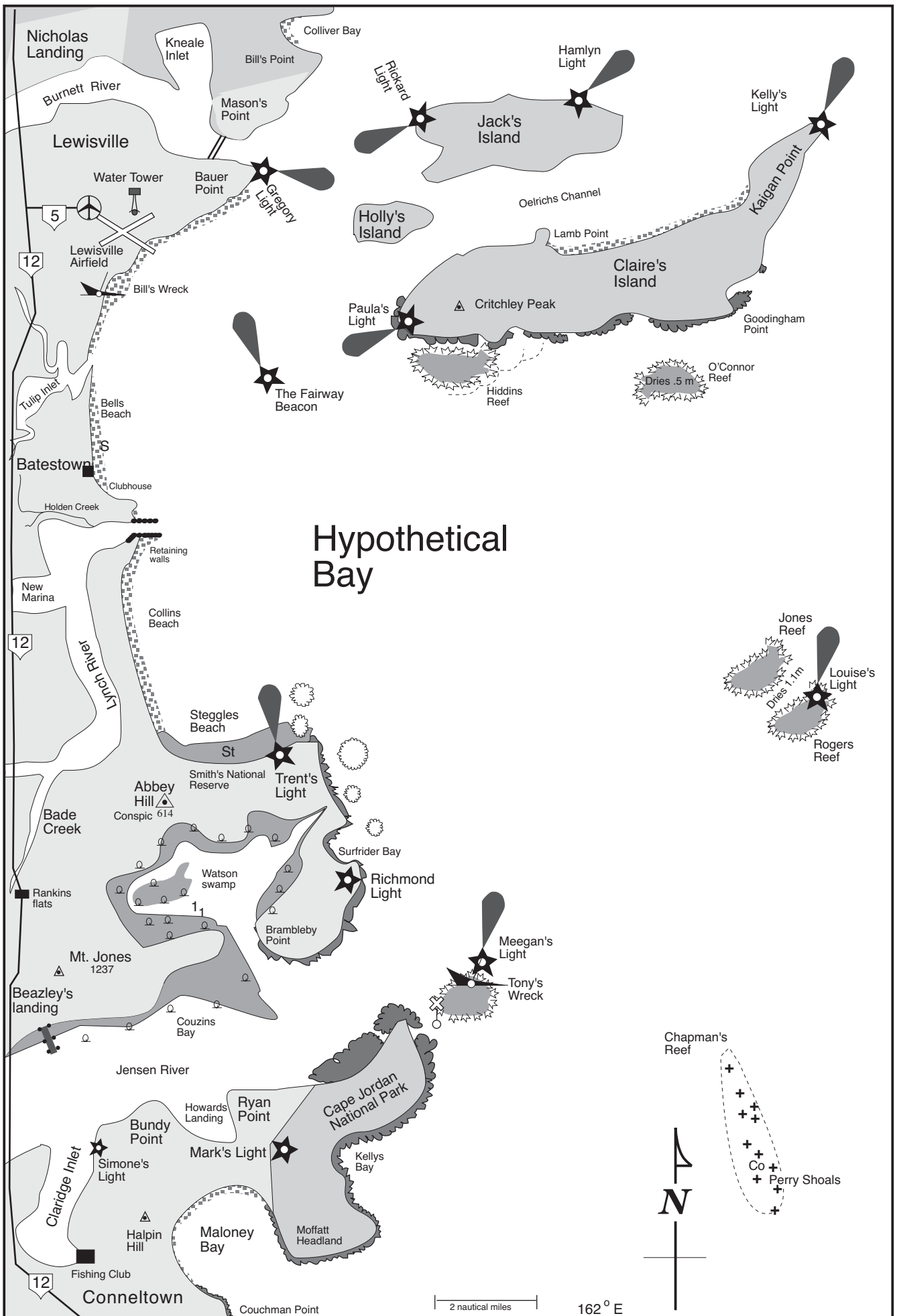
---

---

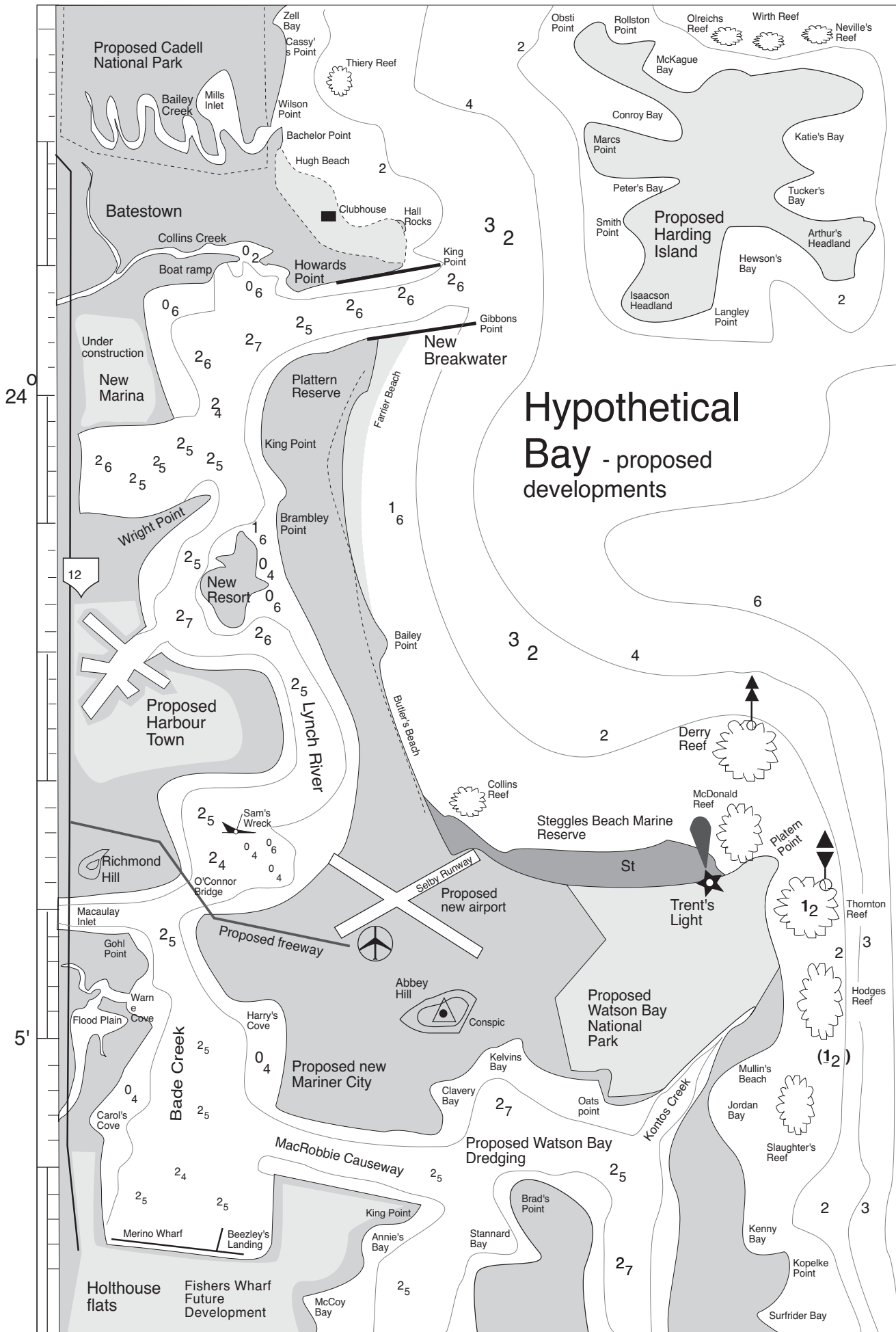
---



# 5.8 Hypothetical Bay

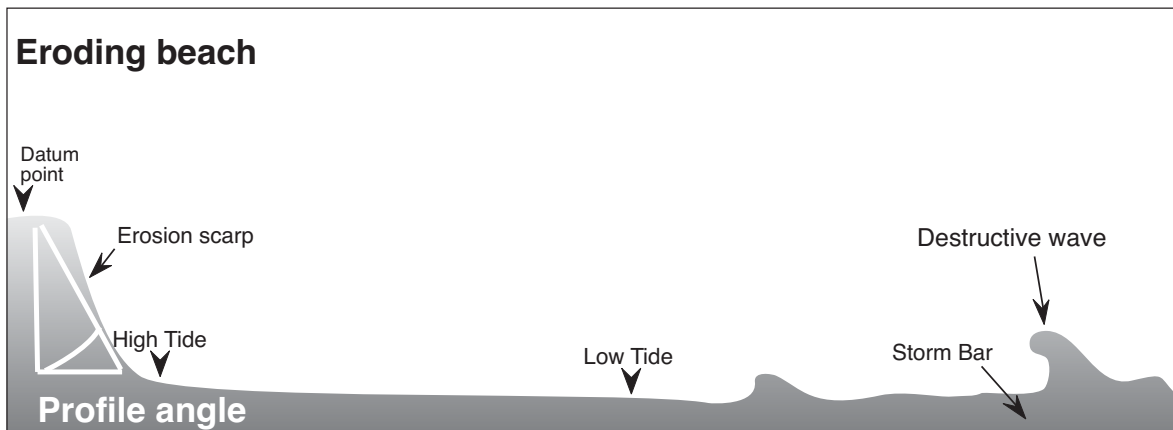
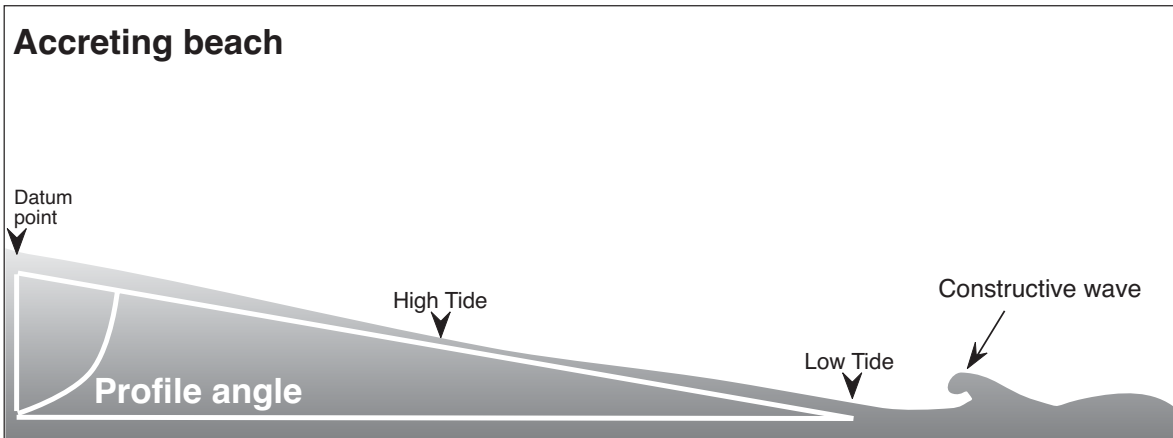
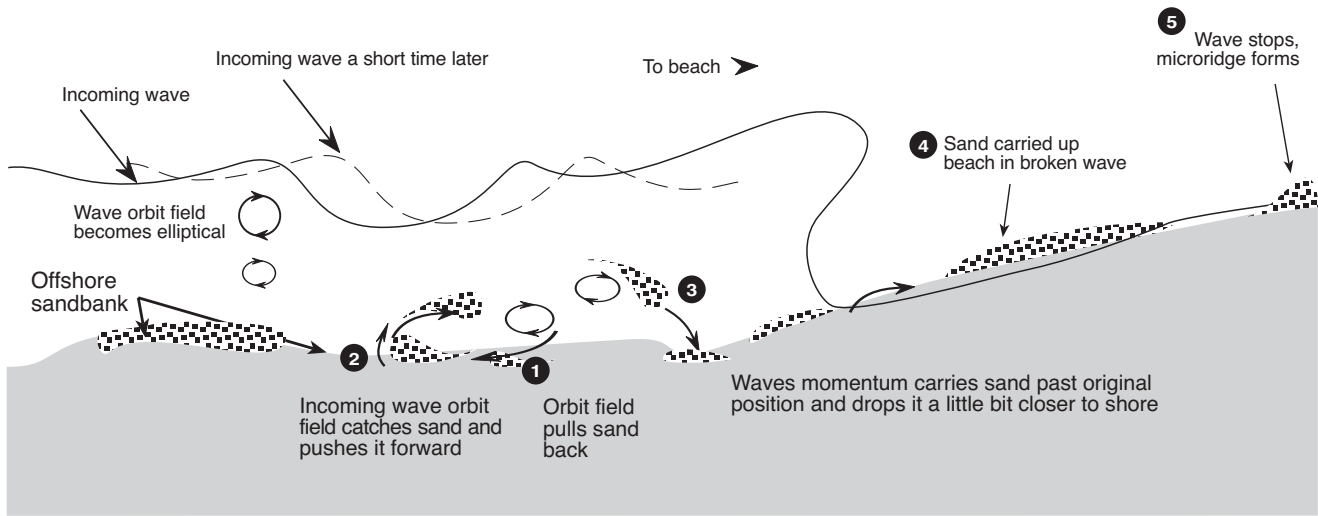


## 5.9 Hypothetical Bay development

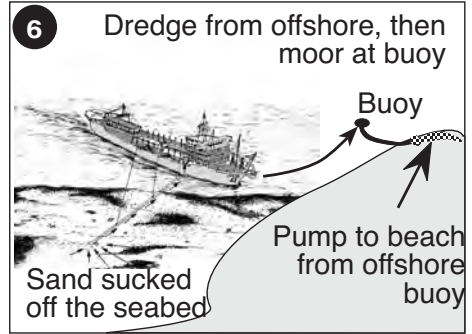
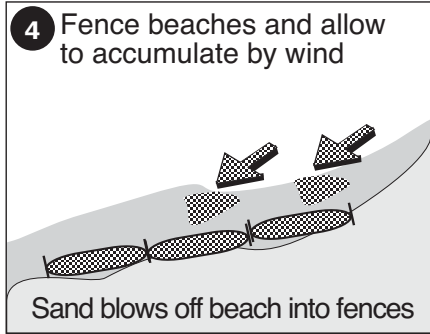
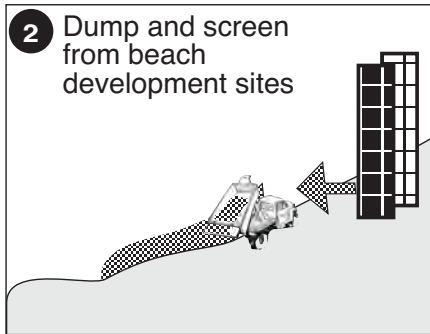
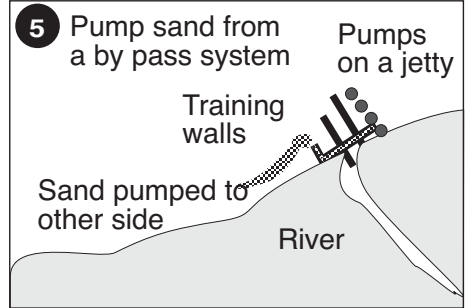
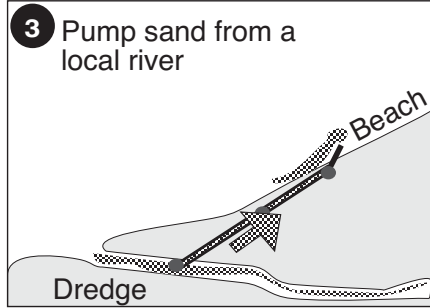
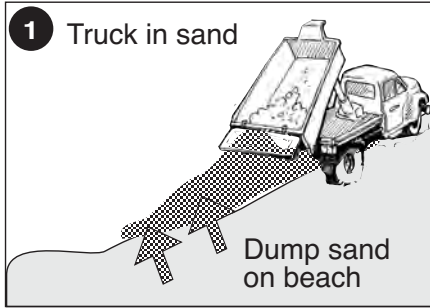




## 5.11 Sand dune systems







**Notes**

---

---

---

---

---

---

---

---

---

---

---

---

---

---

---

---

---

---

---

---

---

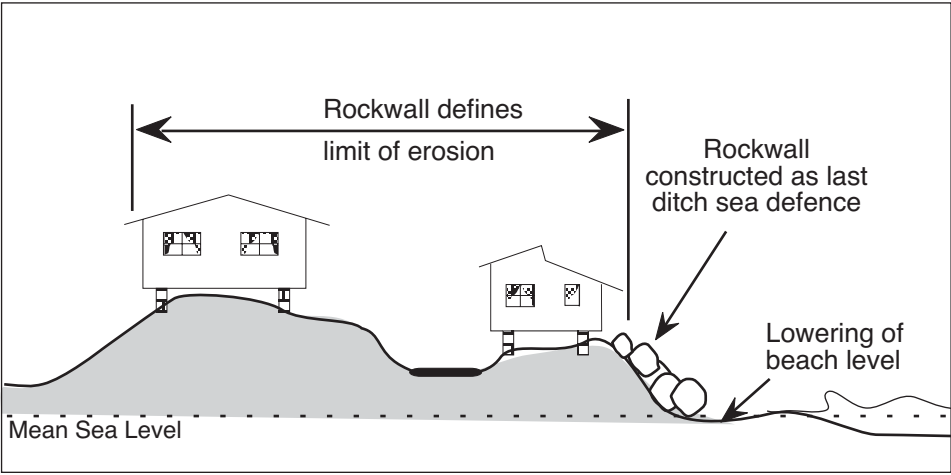
---

---

---

---

### 5.13 Boulder walls



**Notes**

---

---

---

---

---

---

---

---

---

---

---

---

---

---

---

---

---

---

---

---

---

---

---

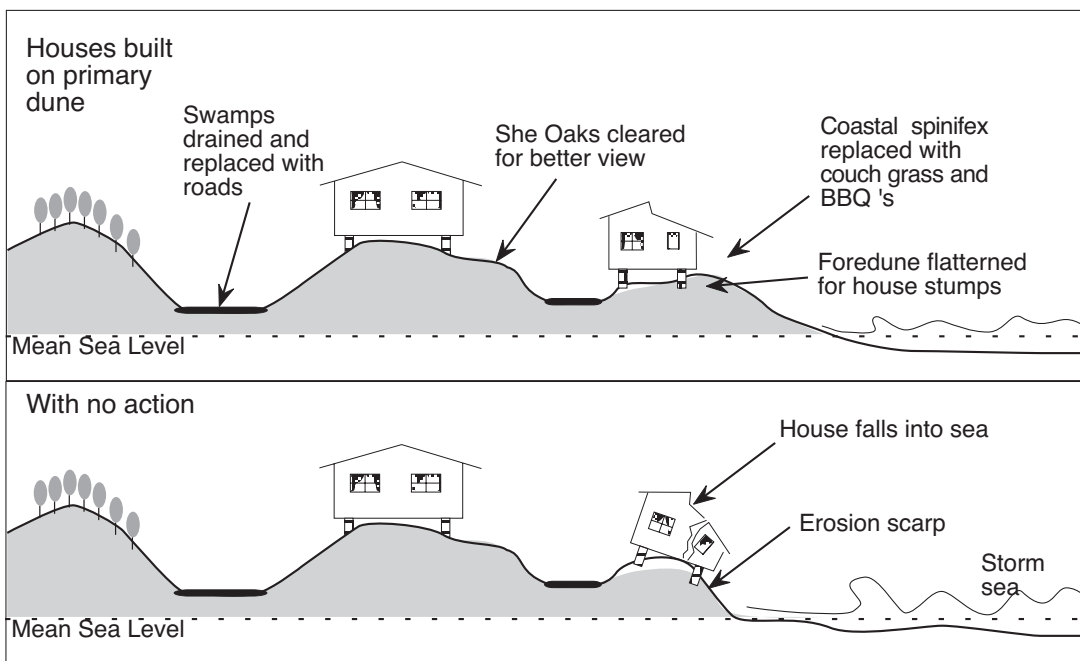
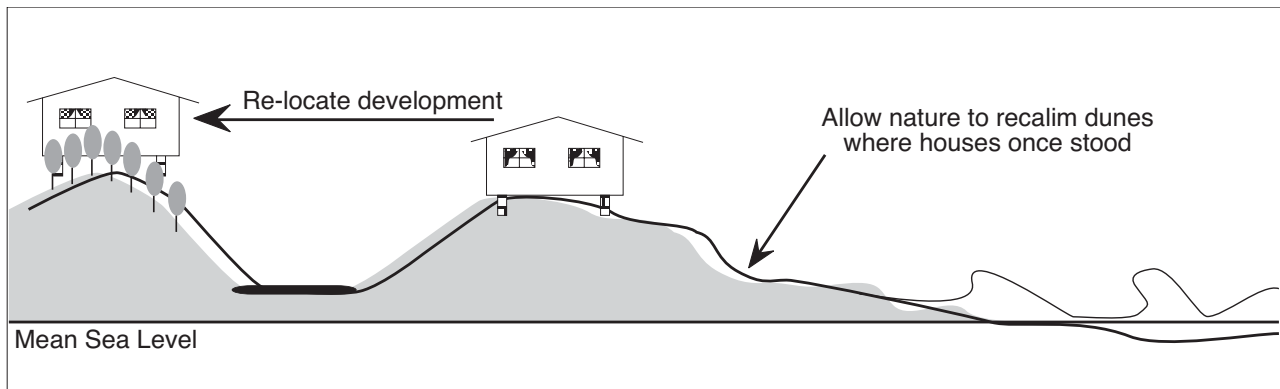
---

---

---

---

## 5.14 Beach erosion and housing development



## Notes

---



---



---



---



---



---



---



---



---

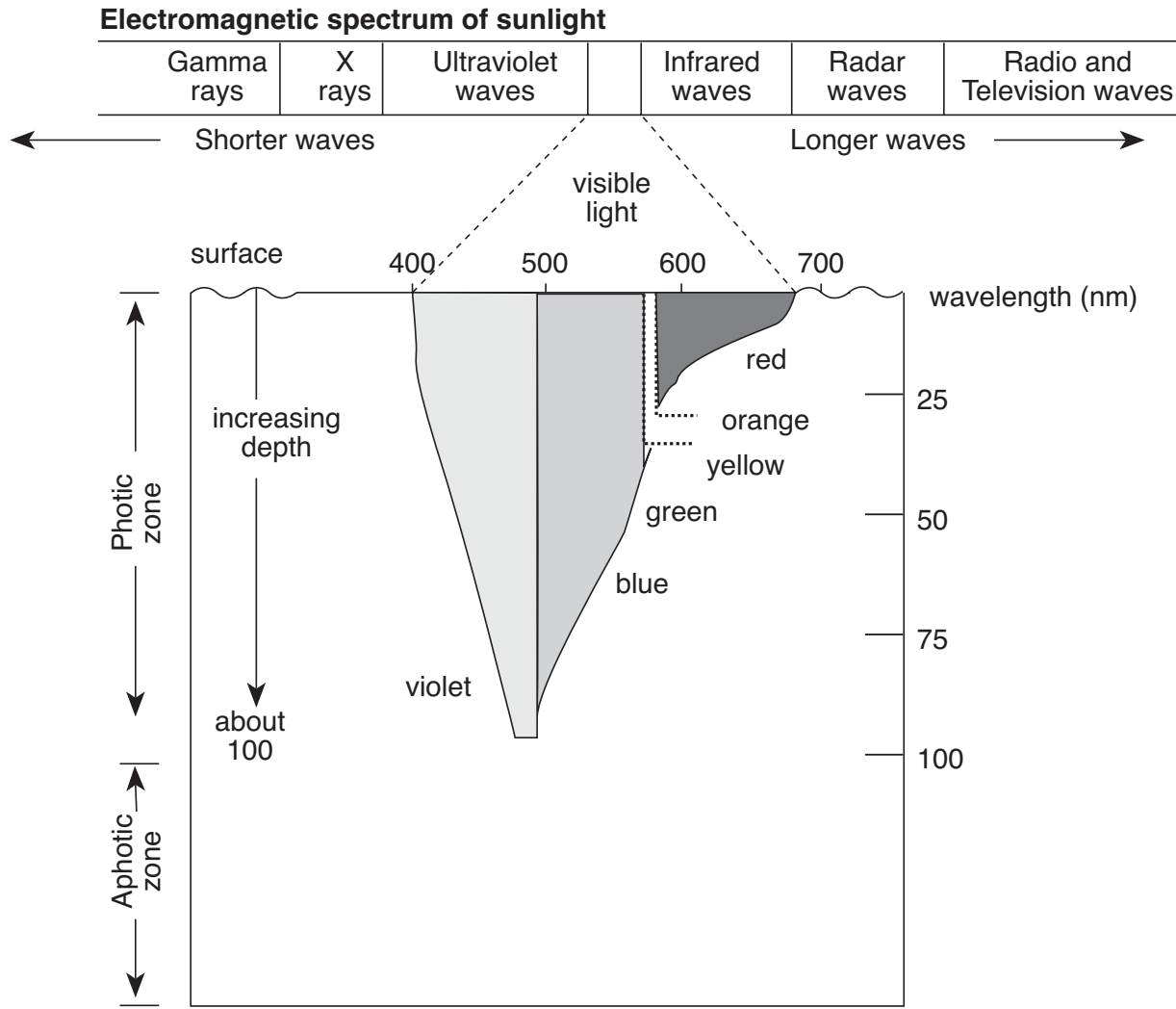


---





# 5.16 Seawater and light



### Notes

---

---

---

---

---

---

---

---

---

---

---

---

---

---

---

---

---

---

---

---

---

---

---

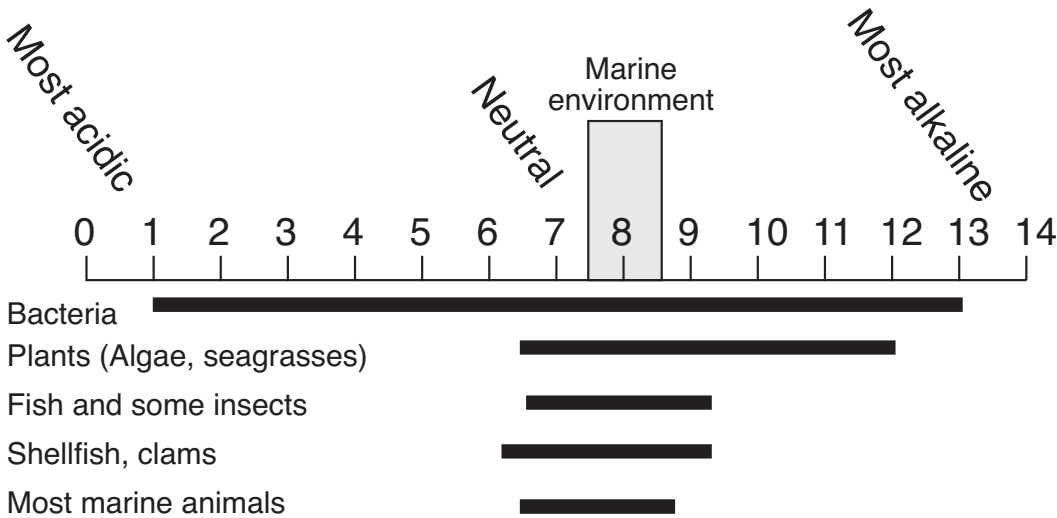
---

---

---

---

# 5.17 Seawater and pH



## Notes

---

---

---

---

---

---

---

---

---

---

---

---

---

---

---

---

---

---

---

---

---

---

---

---

---

---



[www.wetpaper.com.au](http://www.wetpaper.com.au)